

DEPARTMENT OF THE ARMY FIELD MANUAL

FM 8-9

DEPARTMENT OF THE NAVY PUBLICATION

NAVMED-P-5059

DEPARTMENT OF THE AIR FORCE JOINT MANUAL

AFJMAN 44-151

---

# **NATO HANDBOOK ON THE MEDICAL ASPECTS OF NBC DEFENSIVE OPERATIONS AMedP-6(B)**

**PART I - NUCLEAR**

**PART II - BIOLOGICAL**

**PART III - CHEMICAL**

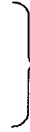
**DISTRIBUTION RESTRICTION: Approved for public release; distribution is unlimited.**

---

**DEPARTMENTS OF THE ARMY, THE NAVY, AND THE AIR FORCE**

**FEBRUARY 1996**

ARMY FIELD MANUAL 8-9  
NAVY MEDICAL PUBLICATION 5059  
AIR FORCE JOINT MANUAL 44-151



\*FM 8-9  
\*NAVMED P-5059  
\*AFJMAN 44-151

DEPARTMENTS OF THE  
ARMY, THE NAVY,  
AND THE AIR FORCE  
Washington, D. C., 1 February 1996

**NATO HANDBOOK ON  
THE MEDICAL ASPECTS OF  
NBC DEFENSIVE OPERATIONS  
AMedP-6(B)**

**DISTRIBUTION RESTRICTION:** Approved for public release; distribution is unlimited.

Use of a trademarked name does not imply endorsement by the U.S. Army, Navy, or Air Force, but is intended only to assist in identification of a specific product.

You can help improve this manual. If you find any mistakes or if you know a way to improve procedures, please let us know. Mail your memorandum or DA Form 2028 (Recommended Changes to Publications and Blank Forms) directly to HQDA (DASG-HCO), 5109 Leesburg Pike, Falls Church, VA 22041-3258.

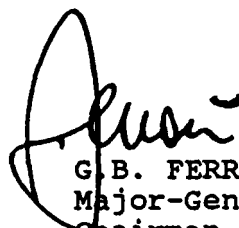
---

\* This publication supersedes FM 8-9/NAVMED P-5059/AFP 161-3, 31 August 1973, including all changes.

NORTH ATLANTIC TREATY ORGANIZATION  
MILITARY AGENCY FOR STANDARDIZATION (MAS)  
NATO LETTER OF PROMULGATION

July 1994

1. AMedP-6(B) - NATO HANDBOOK ON THE MEDICAL ASPECTS OF NBC DEFENSIVE OPERATIONS is a NATO UNCLASSIFIED publication. The agreement of nations to use this publication is recorded in STANAG 2500 NBC/MED.
2. AMedP-6(B) is effective upon receipt. AMedP-6(A) shall be destroyed in accordance with the local procedure for the destruction of documents.



G. B. FERRARI  
Major-General, ITAF  
Chairman, MAS

304/59nh



**PREFACE**

The purpose of this handbook is to provide a guide for medical officers on the medical aspects of NBC operations. The handbook is intended as a compilation of reference material and as a source of information for training. It does not constitute an official position of NATO nations; certain aspects, however, are already covered by STANAGs and this is being extended. In addition, it provides the basic philosophy for the development of concepts of operations and in the management, including evacuation and treatment, of NBC casualties as well as conventional battle casualties in a NBC environment. There are many unresolved problems and it must be appreciated that a number of the philosophical concepts presented are provisional; their validity will require reassessment in the light of future trials and exercises. The handbook is in three parts, Part I-Nuclear, Part II-Biological, and Part III-Chemical. Each part is self-contained and presented separately. There is some necessary overlap and several aspects are common to all three, for example: combined injuries; the effect of radiation on the response to infection and on the healing of thermal and chemical burns; psychological factors and morale; public health aspects; and medical care in a mass casualty situation. It should be noted that detailed information on the treatment of burns and traumatic injuries is contained in the Emergency War Surgery Handbook covered by STANAG 2068, which should be used in conjunction with this handbook.

**NATO HANDBOOK ON THE MEDICAL ASPECTS  
OF NBC DEFENSIVE OPERATIONS  
AMedP-6(B)**

**PART I - NUCLEAR**

**1 FEBRUARY 1996**

## TABLE OF CONTENTS

	Page	
CHAPTER 1	GENERAL INFORMATION	
Paragraph 101.	Purpose of AMedP-6(B), Part I	1-1
102.	General Impact of Nuclear Weapons	1-1
CHAPTER 2	CONVENTIONAL AND NUCLEAR WEAPONS - ENERGY PRODUCTION AND ATOMIC PHYSICS	
SECTION I	- GENERAL	
Paragraph 201.	Introduction	2-1
SECTION II	- MECHANISMS OF ENERGY PRODUCTION	
Paragraph 202.	Definition of Explosion	2-1
203.	Conventional Chemical Explosion	2-1
204.	Nuclear Detonations	2-2
205.	Elements and Atomic Structure	2-2
206.	Isotopes	2-3
207.	Atomic Mass Unit	2-5
208.	Symbols and Notation	2-6
209.	Fission	2-6
210.	Critical Mass	2-7
211.	Fusion	2-10
SECTION III	- RADIOACTIVITY AND NUCLEAR RADIATION	
Paragraph 212.	General	2-10
213.	Radioactivity	2-10
214.	Measurement of Radioactivity	2-11
215.	Nuclear Radiation	2-13
216.	Interaction With Matter	2-14
217.	Gamma Interaction	2-16
218.	Interaction of Charged Particles	2-18
219.	Specific Ionization	2-18
220.	Stopping Power	2-19
221.	Half-Value Layer	2-19
222.	Neutron Interaction	2-20
223.	Elastic Collisions	2-21
224.	Inelastic Collisions	2-22
225.	Neutron-to-Gamma Ratios	2-23
CHAPTER 3	EFFECTS OF NUCLEAR EXPLOSIONS	
SECTION I	- GENERAL	
Paragraph 301.	Introduction	3-1
302.	General Effects of Nuclear Explosions	3-1
303.	Initial Energy Transfer and Formation of Fireball	3-2
304.	Types of Bursts	3-3

	Page
<b>SECTION II - BLAST</b>	
Paragraph 305. Formation of Blast Wave	3-4
306. Propagation of Blast Wave in Air	3-5
307. Static Overpressure and Dynamic Pressure	3-6
308. Blast Loading	3-9
309. Drag Loading	3-10
310. Shock Waves in Other Media	3-10
<b>SECTION III - THERMAL RADIATION</b>	
Paragraph 311. Formation of Thermal Radiation	3-11
312. Propagation of Thermal Energy	3-11
313. Rate of Thermal Emission	3-12
314. Shielding	3-13
315. Yield and Altitude	3-13
316. Thermal Effects	3-14
<b>SECTION IV - NUCLEAR RADIATION</b>	
Paragraph 317. Sources of Nuclear Radiation	3-15
318. Initial Radiation	3-16
319. Residual Radiation	3-17
320. Fallout	3-17
<b>CHAPTER 4     BIOLOGICAL EFFECTS OF A NUCLEAR EXPLOSION</b>	
<b>SECTION I   - GENERAL</b>	
Paragraph 401. Introduction	4-1
<b>SECTION II - BLAST INJURY</b>	
Paragraph 402. General	4-1
403. Direct Blast Injury	4-1
404. Indirect Blast Wind Drag Forces	4-3
405. Missile Injury	4-3
406. Crush and Translational Injuries	4-5
<b>SECTION III - THERMAL INJURY</b>	
Paragraph 407. Mechanism of Injury	4-6
408. Thermal Effects	4-6
409. Thermal Energy and Burns to Exposed Skin	4-6
410. Flash Burns Under Clothing	4-7
411. Flame Burns	4-8
412. Eye Injuries	4-8
<b>CHAPTER 5     BIOPHYSICAL AND BIOLOGICAL EFFECTS OF IONIZING                   RADIATION</b>	
<b>SECTION I   - GENERAL</b>	
Paragraph 501. Introduction	5-1



	Page
<b>SECTION II - BASIC BIOPHYSICAL ACTION OF IONIZING RADIATION</b>	
Paragraph 502. Nuclear Radiation	5-1
503. Gamma Radiation	5-2
504. Neutron Radiation	5-2
505. Beta Radiation	5-4
506. Alpha Radiation	5-5
507. Radiochemical Action	5-6
<b>SECTION III - CELLULAR EFFECTS OF IONIZING RADIATION</b>	
Paragraph 508. General	5-7
509. Relative Cellular Radiosensitivity	5-8
510. Relative Organ Radiosensitivity	5-9
511. Radiation-Induced Chromosome Damage	5-9
512. Genetic Effects	5-10
513. Cell Kinetic Effects	5-10
514. Bone-Marrow Kinetics	5-11
515. Erythropoietic	5-11
516. Myelopoietic	5-12
517. Thrombopoietic	5-12
518. Gastrointestinal Kinetics	5-13
<b>SECTION IV - SYSTEMIC EFFECTS OF WHOLE-BODY IRRADIATION</b>	
Paragraph 519. General	5-14
520. Median Lethal Dose (LD <sub>50</sub> )	5-14
521. Reproductive Cell Kinetics and Sterility	5-18
522. Recovery	5-18
<b>SECTION V - DELAYED EFFECTS</b>	
Paragraph 523. General	5-21
524. Carcinogenesis	5-21
525. Cataract Formation	5-21
526. Chronic Radiodermatitis	5-22
<b>SECTION VI - INTERNAL IRRADIATION</b>	
Paragraph 527. Introduction	5-22
528. Incorporation of Radioactive Material	5-23
529. Elimination of Isotopes	5-24
<b>CHAPTER 6 GENERAL MEDICAL EFFECTS OF NUCLEAR WEAPONS: DIAGNOSIS, TREATMENT, AND PROGNOSIS</b>	
<b>SECTION I - GENERAL</b>	
Paragraph 601. Introduction	6-1
<b>SECTION II - BLAST INJURIES</b>	
Paragraph 602. General	6-1
603. Diagnosis	6-1

	Page
Paragraph 604. Treatment	6-1
<b>SECTION III - THERMAL INJURIES</b>	
Paragraph 605. General	6-2
606. Diagnosis	6-2
607. Area of Burn	6-2
608. Involvement of Critical Organs	6-3
609. Depth of Burn	6-4
610. Treatment	6-4
611. Care of Burn Wound	6-6
<b>SECTION IV - RADIATION INJURY AND COMBINED INJURY</b>	
Paragraph 612. General	6-6
613. Clinical Course of Radiation Sickness	6-7
614. Hematopoietic Syndrome	6-17
615. Gastrointestinal Syndrome	6-17
616. Neurovascular Syndrome	6-19
617. Diagnosis	6-20
618. Decontamination of Patient	6-23
619. Initial Treatment for Patients With Whole-Body Radiation Injury	6-24
620. Diagnosis and Treatment of Patient With Combined Injuries	6-25
621. Management of Infection	6-25
622. Future Concerns for Management of Radiation Injuries	6-26
623. Effect of Radiation Injury on Response to Trauma	6-27
624. Effect of Injuries on Response to Radiation Sickness	6-28
<b>SECTION V - PUBLIC HEALTH ASPECTS OF NUCLEAR WARFARE</b>	
Paragraph 625. Epidemic Disease Hazards Caused by Nuclear War	6-30
626. Biomedical Impact of Nuclear Winter	6-31
<b>SECTION VI - PSYCHOLOGICAL ASPECTS OF NUCLEAR WARFARE</b>	
Paragraph 627. General	6-31
628. Diagnosis	6-32
629. Factors Determining Response	6-32
630. Treatment	6-33
631. Prevention	6-34
<b>CHAPTER 7 MEDICAL PLANNING AND OPERATIONS IN NUCLEAR WAR</b>	
<b>SECTION I - GENERAL</b>	
Paragraph 701. Introduction	7-1
<b>SECTION II - STAFF-LEVEL MEDICAL PLANNING AND OPERATIONAL ACTIVITIES</b>	
Paragraph 702. General	7-2
703. Organization of the Medical Support System	7-2
704. Mobility of Medical Support	7-3

	Page
Paragraph 705. Coordination with other Allies	7-3
706. Casualty and Damage Assessment	7-3
707. Logistical Support System	7-4
708. Personnel and Medical Unit Requirements	7-5
709. Command Radiation Guidance	7-5
<b>SECTION III - MEDICAL UNIT PLANNING AND OPERATIONAL ACTIVITIES</b>	
Paragraph 710. General	7-7
711. Unit Mobility	7-7
712. Rescue and Damage Control	7-9
713. Handling Large Numbers of Casualties	7-9
714. Unit Operations in Fallout	7-10
715. Performance of Mission in a Radiologically Contaminated Environment	7-10
716. Field Expedient Fallout Shelters	7-12
717. Handling of Radiologically Contaminated Patients	7-13
718. Patient Decontamination	7-14
ANNEX	
A RADIATION DETECTION AND MEASUREMENT	A-1
B HAZARDS OF NUCLEAR WEAPONS ACCIDENTS	B-1
C GENERAL GUIDELINES FOR MEDICAL SUPPORT IN NUCLEAR ACCIDENTS	C-1
REFERENCES	References-1
GLOSSARY	Glossary-1
INDEX	Index-1

### List of Figures

	Page
Figure 2-I. A Typical Atom	2-2
2-II. Illustration of a Molecule (H <sub>2</sub> O)	2-3
2-III. Isotopes of Uranium	2-4
2-IV. Neutron to Proton Ratios	2-4
2-V. Illustration of a Mass Defect	2-5
2-VI. Fission Process	2-7
2-VII. Gun Assembly Principle	2-8
2-VIII. Implosion Assembly Principle	2-9
2-IX. Weapon Energy Distribution	2-9
2-X. Radioactive Decay Plotted in Linear Form	2-11
2-XI. Radioactive Decay Plotted in Semilogarithmic Form	2-11

		Page
Figure 2-XII.	Excitation of an Electron	2-15
2-XIII.	Electron Removal by Ionization	2-16
2-XIV.	Gamma Interaction by Photoelectric Effect	2-16
2-XV.	Gamma Interaction by Compton Scattering	2-17
2-XVI.	Gamma Interaction by Pair Production	2-18
2-XVII.	Attenuation of Gamma Radiaton	2-20
2-XVIII.	An Elastic Collision	2-21
2-XIX.	An Inelastic Collision	2-22
3-I.	Chronological Development of an Air Burst	3-5
3-II.	Variations of Overpressure and Dynamic Pressure with Time	3-7
3-III.	Variations of Blast Effects Associated with Positive and Negative Phase Pressures with Time	3-8
3-IV.	Emission of Thermal Radiation in Two Pulses in an Air Blast	3-12
3-V.	Slant Ranges for Specified Radiant Exposures as Functions of Energy Yield of the Explosion	3-13
4-I.	Flashblindness and Retinal Burn Safe Separation	4-9
5-I.	Typical Lethality as a Function of Dose	5-15
5-II.	Lethality Response as a Function of Dose Obtained by Probit Analysis	5-16
6-I.	Acute Clinical Effects of Single-Dose Rate Exposure of Whole-Body Irradiation to Healthy Adults (1 of 9)	6-8
	Acute Clinical Effects of Single-Dose Rate Exposure of Whole-Body Irradiation to Healthy Adults (2 of 9)	6-9
	Acute Clinical Effects of Single-Dose Rate Exposure of Whole-Body Irradiation to Healthy Adults (3 of 9)	6-10
	Acute Clinical Effects of Single-Dose Rate Exposure of Whole-Body Irradiation to Healthy Adults (4 of 9)	6-11
	Acute Clinical Effects of Single-Dose Rate Exposure of Whole-Body Irradiation to Healthy Adults (5 of 9)	6-12
	Acute Clinical Effects of Single-Dose Rate Exposure of Whole-Body Irradiation to Healthy Adults (6 of 9)	6-13
	Acute Clinical Effects of Single-Dose Rate Exposure of Whole-Body Irradiation to Healthy Adults (7 of 9)	6-14
	Acute Clinical Effects of Single-Dose Rate Exposure of Whole-Body Irradiation to Healthy Adults (8 of 9)	6-15
	Acute Clinical Effects of Single-Dose Rate Exposure of Whole-Body Irradiation to Healthy Adults (9 of 9)	6-16
6-II.	Smoothed Average Time-Course of Neutrophil Changes in Human Cases from Accidental Radiation Exposure as a Function of Dose	6-18

		Page
Figure 6-III.	Smoothed Average Time-Course of Platelet Changes in Human Cases from Accidental Radiation Exposure as a Function of Dose	6-19
6-IV.	Smoothed Average Time-Course of Lymphocyte Changes in Human Cases from Accidental Radiation Exposure as a Function of Dose	6-19
6-V.	Clinical Effects of Whole Body Irradiation in Humans	6-30
7-I.	Expected Response to Radiation for Physically Demanding Tasks	7-6
7-II.	Expected Response to Radiation for Physically Undemanding Tasks	7-7
A-I.	Pocket Dosimeter	A-6
A-II.	Radial Plot	A-9
A-III.	Grid Plot	A-9

### List of Tables

			Page
Table	2-I.	Radioactive Decay	2-14
	2-II.	Specific Ionization of Radiation	2-19
	2-III.	Typical Neutron-to-Gamma and Neutron Dose-to-Total Dose Ratios	2-23
	3-I.	Radii of Effects of Nuclear Weapons	3-2
	3-II.	Failure of Overpressure Sensitive Structural Elements	3-9
	3-III.	Approximate Radiant Exposures for Ignition of Fabrics for Low Air Burst	3-16
	4-I.	Range of Lethality at Peak Overpressure	4-2
	4-II.	Ranges for Different Probabilities of Injury from Small Missiles	4-4
	4-III.	Probability of Penetration of Glass Fragments and Associated Kinetic Energy Related to Size and Velocity	4-4
	4-IV.	Translational Injuries	4-5
	4-V.	Ranges for Selected Impact Velocities of a 70-kg Human Body Displaced by Blast Wind Drag Forces for Different Yield Weapons	4-5
	4-VI.	Factors for Determining Probability of Second-Degree Burns to Bare Skin	4-7
	4-VII.	Incident Exposure Necessary to Cause Second-Degree Burns Under Clothing	4-7

		Page
Table 5-I.	Relative Biological Effectiveness	5-3
5-II.	Tissue Dose Rate at Various Distances Around a 37 KBq (1 $\mu$ Ci) Particle of Various Beta Emitting Materials (Range in Tissue 1-10 mm)	5-5
5-III.	Tissue Dose Rate at Various Distances from a 38 Mbq (1 $\mu$ Ci) Alpha Emitter	5-5
5-IV.	Relative Radiosensitivity of Various Organs Based on Parenchymal Hypoplasia	5-9
5-V.	Radiation Dermatitis	5-22
6-I.	Rule of Nines for Establishing Extent of Body Surface Burned	6-3
6-II.	Preliminary Triage of Casualties with Possible Radiation Injuries	6-22
7-I.	Biological Response to Nuclear Radiation and Medical Care of Casualties	7-8
7-II.	Shielding Properties of Common Materials from Fallout Gamma Radiation	7-11
7-III.	The 7:10 Rule for Residual Radiation Decay	7-12



## CHAPTER 1

## GENERAL INFORMATION

**101. Purpose of AMedP-6(B), Part I.**

The purpose of this publication is to provide medical personnel of the NATO Armed Forces with information on the biomedical effects of nuclear weapons and the impact of the use of nuclear weapons on the different aspects of medical field operations.

**102. General Impact of Nuclear Weapons.**

- a. Total nuclear war with utilization of all available nuclear weapons could result in complete devastation of the involved nations' military combat and logistic systems as well as their supporting civilian social structures and economies. (See paragraphs 625 and 631.) However, situations short of total nuclear war are possible in which nuclear weapons could be employed in limited numbers or for a limited time, along with conventional weapons. Under such circumstances, effective military operations could continue and would require the continuing support of an effective medical service.
- b. It is essential that medical personnel at all levels be prepared for the problems associated with limited nuclear warfare. This handbook has been prepared to provide those responsible for medical support planning, training, and field operations with specific information critical to the understanding and solution of these special problems. The subjects covered in this publication are many and varied, reflecting the complexities involved in the nuclear sciences and the varied needs of the people for whom this book was prepared. Accordingly, the subject matter presented includes discussions of atomic structure and radioactivity, characteristics of nuclear detonations, descriptions of the factors related to the diagnosis, treatment and prognosis of nuclear warfare casualties, and guidance applicable to the organization and operation of medical units on a nuclear battlefield. In addition, information has been included on the special problems associated with nuclear accidents in peacetime.

## CHAPTER 2

CONVENTIONAL AND NUCLEAR WEAPONS - ENERGY PRODUCTION AND  
ATOMIC PHYSICS

## SECTION I - GENERAL

**201. Introduction.**

As a first step in developing an understanding of the medical implications of nuclear warfare, it is essential to understand how a nuclear weapon differs from a conventional high explosive weapon. Accordingly, a comparison will be made in this chapter between the mechanisms of energy production in conventional and nuclear detonations. In addition, certain principles of atomic structure and physics are presented to aid in the understanding of these differences.

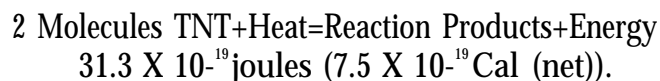
## SECTION II - MECHANISMS OF ENERGY PRODUCTION

**202. Definition of Explosion.**

An explosion can be described as the sudden release of large amounts of energy within a limited space as the system involved is converted to a more stable one. The basic laws of thermodynamics pertaining to the conservation of energy require that energy must be released when a system is converted to another of greater stability, i.e., one containing less energy.

**203. Conventional Chemical Explosion.**

- a. The molecules of conventional chemical explosives are considered to be in a high-energy or unstable state. When such a system is made to react, products of greater stability are formed and energy is released. With a conventional explosive, such as trinitrotoluene (TNT), the energy is derived from a sudden, violent chemical reaction, altering various bonds between the molecules of the explosive's chemical compounds, i.e.,



The amount of energy released in such a reaction is directly proportional to the difference between the total binding energy contained within the initial, unstable system and that contained within the final, more stable system. This net energy release is called the heat of explosion.

- b. As in all chemical reactions, mass and energy are conserved separately; i.e., by the best methods of measurement available, the total mass and the total energy, including the heat of explosion, are found to be exactly the same, respectively, before and after the explosion.

## 204. Nuclear Detonations.

Energy released in a nuclear explosion is not produced by chemical reactions. Rather, it results from so-called nuclear reaction, fission and fusion, in which fundamental changes occur in the composition of the nuclei of the reacting material rather than in the electron shells as is the case in chemical reactions. In these nuclear reactions mass is actually converted to energy, and the amount of energy produced is many orders of magnitude greater than that available from chemical reactions. To fully appreciate the nature of these reactions, certain basic concepts related to atomic structure and nuclear reactions must first be understood.

## 205. Elements and Atomic Structure.

- a. *Elements.* All substances are composed of one or more of over 100 different kinds of basic materials known as elements. There are 92 naturally occurring and at least 11 artificially produced elements, ranging from the simplest and lightest naturally occurring element hydrogen to the heaviest artificial element lawrencium.
- b. *Atomic Structure.* The simplest structural unit of any element that can exist, while still retaining the chemical and physical characteristics of the element, is called an atom. An atom is composed of a central nucleus containing most of its mass and electrons orbiting in shells around the nucleus (Figure 2-1). The nucleus consists of a number of fundamental particles, the most important of which are the protons and neutrons.
  - (1) The proton is a particle having a positive charge, equal in magnitude and opposite in sign to that of the electron. The proton's mass is approximately 1845 times greater than that of the electron.
  - (2) The neutron is an uncharged particle having a mass slightly greater than that of the proton, approximately equal to the sum of the masses of a proton and an electron.
  - (3) Electrons are negatively charged particles. They orbit the nucleus at discrete energy levels referred to as electron shells.

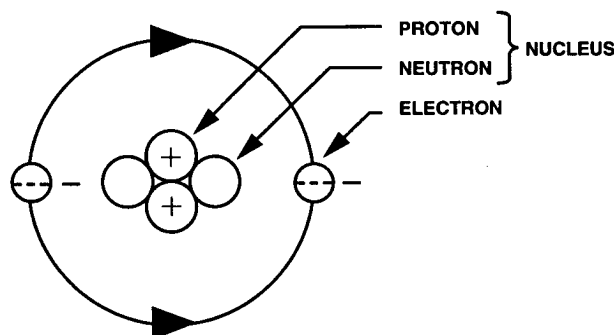


Figure 2-1. A Typical Atom

- c. *Electrical Charge.* Atoms are electrically neutral when the number of negatively charged electrons orbiting the nucleus equals the number of positively charged protons within the nucleus. When the number of electrons is greater than or less than the number of protons in the nucleus, atoms are not electrically neutral and carry a net negative or positive charge. They are then termed ions and are chemically reactive, tending to combine with other ions of opposite net charge. When atoms are combined in molecules, they may share electrons to achieve stability of electron shell structure (Figure 2-II).

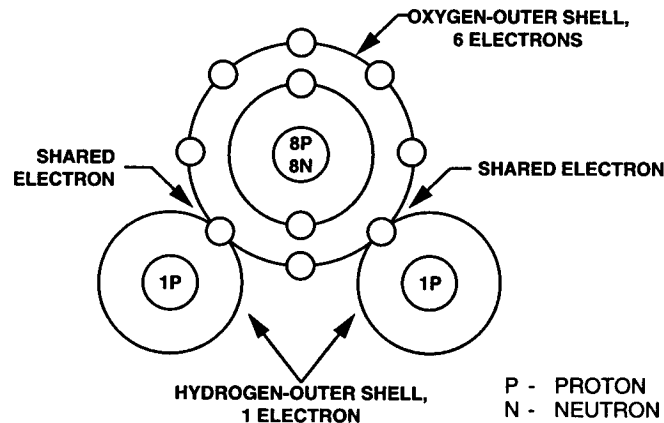


Figure 2-II. Illustration of a Molecule (H<sub>2</sub>O)

## 206. Isotopes.

- a. Atoms of different elements have different numbers of protons in their nuclei. The term atomic number describes the number of protons in a nucleus. Although all the nuclei of a given element will have the same atomic number, they may have different atomic masses because they may contain different numbers of neutrons. Generally, this does not affect the chemical properties of the different atoms since the numbers of protons are not changed but does have profound effects upon nuclear stability of the different atoms. The total number of protons and neutrons in an atomic nucleus is referred to as the atomic mass number. Atomic species which have identical atomic numbers but different atomic mass numbers are called isotopes (Figure 2-III).

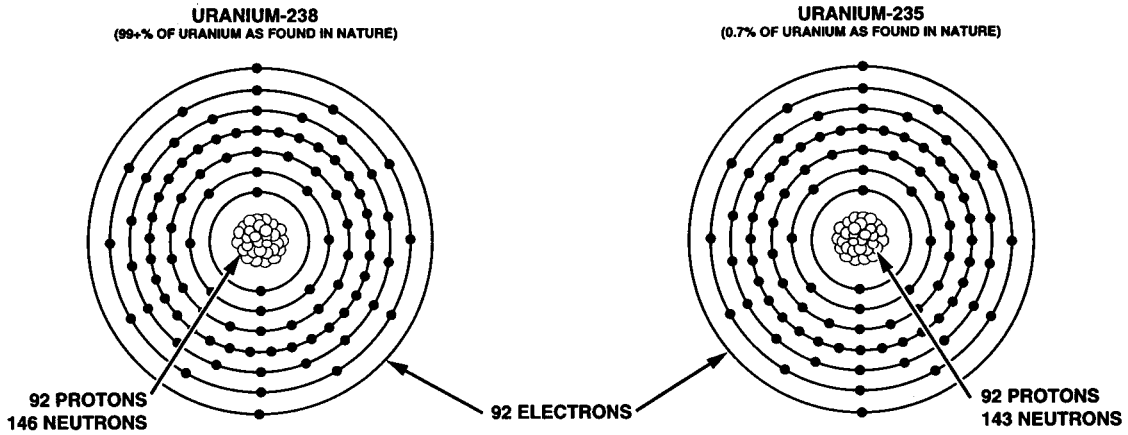


Figure 2-III. Isotopes of Uranium

b. The stable isotopes of elements have very definite ratios of neutrons to protons in their nuclei. As atomic mass numbers increase, the ratio of neutrons to protons increases according to a definite pattern (Figure 2-IV). If isotopes vary from this pattern, they are relatively unstable.

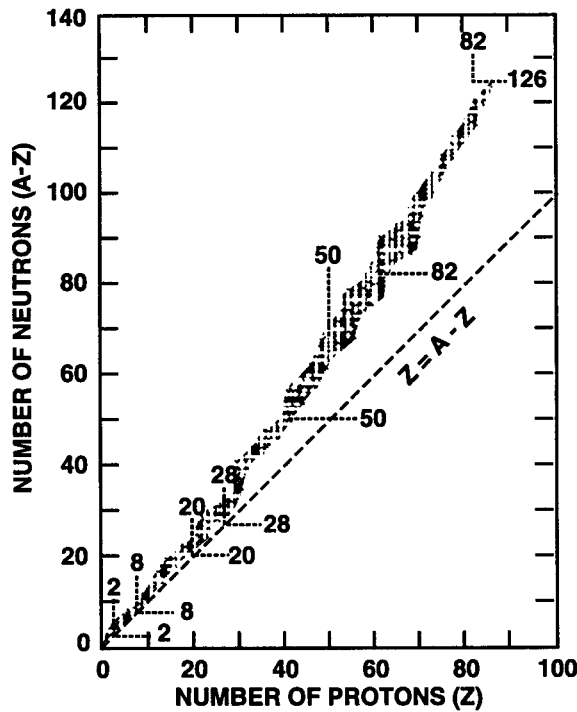
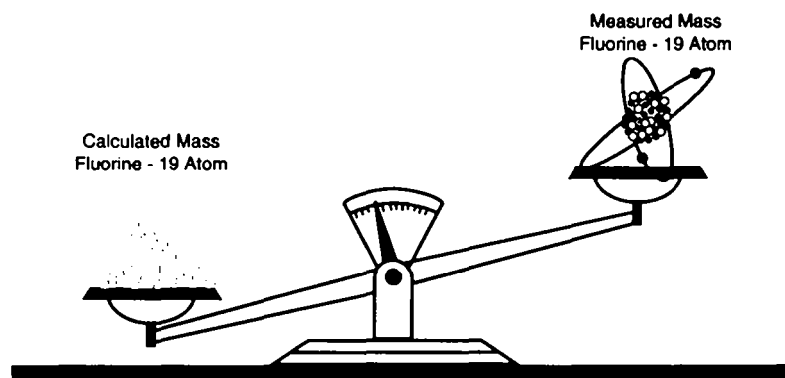


Figure 2-IV. Neutron to Proton Ratios

**207. Atomic Mass Unit.**

- a. Common units of mass, such as grams, are much too large to conveniently describe the mass of an atomic nucleus or any of its constituent parts. To solve this problem a new unit was defined: the atomic mass unit (amu). The atomic mass unit is a relative unit defined arbitrarily by assigning a mass of 12 amu to the neutral atom carbon-12, the common isotope of carbon. One atomic mass unit equals  $1.66 \times 10^{-24}$  grams. Employing this value, the masses of the fundamental particles of an atom have been determined to be:
- (1) Proton mass: 1.00727 amu.
  - (2) Neutron mass: 1.00867 amu.
  - (3) Electron mass: 0.00055 amu.
- b. Logically, it should be possible, knowing the number of particles comprising a particular atom, to calculate the mass of that atom. However, experiments have shown that the total mass of an atom is less than the sum of the masses of the atom's electrons, protons, and neutrons. For example, the measured mass of the isotope fluorine-19 atom is 18.99840 amu, while the sum of the masses calculated for the individual particles of that atom is 19.15708 amu. The difference of 0.15868 amu between the measured and calculated mass of the fluorine-19 atom is defined as the mass defect (Figure 2-V).
- c. Careful experimentation and study have shown that while the mass defect is real, the law of conservation of mass has not been violated. When basic particles combine to form an atom, a certain amount of mass is lost through conversion into energy in accordance with Einstein's equation  $E = mc^2$ , where  $E$  is the energy,  $m$  is the mass, and  $c$  is the velocity of light in a vacuum. The converted energy is considered to be binding energy, i.e., energy necessary to hold the nucleus together.



*Figure 2-V. Illustration of a Mass Defect*

**208. Symbols and Notation.**

- a. A standard notational form is used to identify the individual isotopes of a given element. The standard notation takes the following form:

$$\begin{array}{c} A \\ X \\ Z \end{array}$$

where X = chemical symbol of the element, Z = atomic number, and A = atomic mass number.

- b. An example of the standard notation would be:

$$\begin{array}{c} 235 \\ U \\ 92 \end{array}$$

- c. Reference to a chart of the nuclides would reveal that the element with an atomic number of 92 is uranium, the chemical symbol for which is U. The atomic mass number <sup>235</sup> identifies a uranium isotope having 92 protons and 143 neutrons (235 - 92=143) in its nucleus. Thus the isotope identified by the example notation is the naturally occurring, readily fissionable isotope of uranium used in nuclear weapons. The atomic number is frequently left off, and such an isotope may then be represented only by its mass number and chemical symbol, i.e., <sup>235</sup>U.

**209. Fission.**

- a. Fission is a nuclear process in which a heavier unstable nucleus divides or splits into two or more lighter nuclei, with the release of substantial amounts of energy. The materials used to produce nuclear explosions by fission are those isotopes of uranium or plutonium which undergo fission most readily. These are <sup>235</sup>U and <sup>239</sup>Pu. When as illustrated in Figure 2-VI, a free neutron of the proper energy is captured by the nucleus of a fissionable atom, the resulting unstable nucleus will "split" producing two or more fission products (atoms of different elements formed from the protons, neutrons, and electrons originally comprising the nucleus before its fission), two or three free neutrons and a tremendous amount of energy.
- b. In terms of continued energy production, the most significant point about the fission process is the emission of free neutrons, which can in turn produce other fission events, which in turn produce still another generation of free neutrons. Each generation of fission produced neutrons can produce a large number of fissions; and so, within a few generations, the total number of fissions produced can be tremendous.
- c. While in principle a single neutron could initiate a chain reaction of nuclear fissions which could ultimately result in the splitting of each fissionable atom in a given mass, not all of the neutrons produce more fissions. Some of the neutrons may

escape from the fissionable mass. Others may be removed by nonfission reactions. To initiate a chain reaction, sustain that reaction for a period sufficiently long to permit a buildup of explosive energy, and confine the released energy for as long as possible to maximize the weapon's explosive effect requires that a variety of special conditions be met.

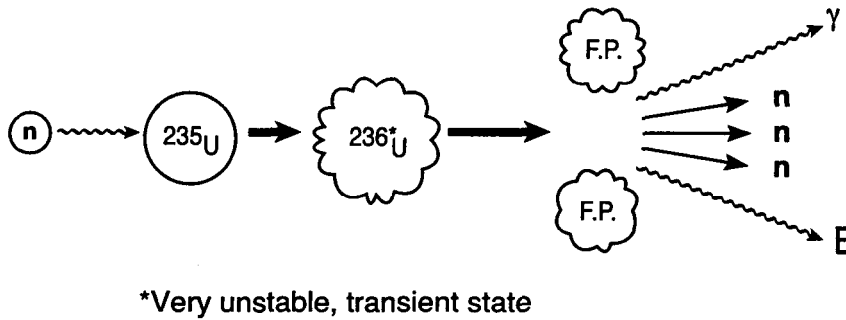


Figure 2-VI. Fission Process

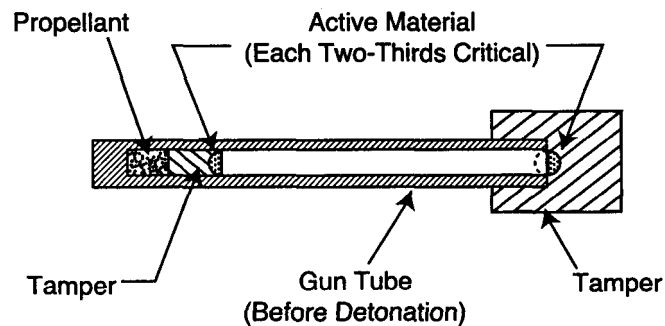
## 210. Critical Mass.

The first prerequisite to be met in producing a fission-type nuclear explosion is that there must be enough material present and in the right configuration so that successive generations of neutrons can cause equal or increased numbers of fissions. The amount capable of sustaining a continuous or chain reaction is termed a critical mass.

- a. Although fission events release more than 2 million times more energy per event than do chemical reactions, there still must be a tremendous number of fissions to result in the release of a significant amount of energy. To meet this requirement, a mass of fissionable material having specific characteristics must be assembled. Depending on size, and other factors to be discussed, a given mass of fissionable material may support one of three types of chain reactions:
  - (1) *Subcritical Chain Reaction.* A reaction in which the number of neutrons decreases in succeeding generations, thus not continuing.
  - (2) *Critical Chain Reaction.* A reaction in which the number of neutrons remains constant in succeeding generations.
  - (3) *Supercritical Chain Reaction.* A reaction in which the number of neutrons increases in succeeding generations.
- b. To produce a nuclear explosion, a weapon must contain an amount of uranium or plutonium that exceeds the mass necessary to support a critical chain reaction, i.e., a supercritical mass of fissionable material is required. Several methods can be used to make a mass of fissionable material supercritical.
  - (1) The active material can be purified to eliminate unwanted chemical impurities that might otherwise absorb neutrons.



- (2) Fissionable material can be enriched, i.e., the amount of  $^{235}\text{U}$  as compared to  $^{238}\text{U}$  can be increased.
  - (3) The material can be machined into the most efficient shape. A spherical shape can be employed to provide the greatest volume with the least surface area, thereby reducing the probability of neutron loss.
  - (4) Moderators can be used to slow down fission neutrons, increasing the probability of their producing fissions.
  - (5) Finally, neutrons that have escaped the active material can be reflected back by using suitable materials as reflectors. Reflectors, used as tampers, can also physically delay the expansion of the exploding material allowing more fission to occur thereby resulting in an increase in explosive energy.
- c. Because of the stray neutrons produced in the environment by spontaneous fission, those present in the atmosphere from cosmic ray interactions as well as others generated in various ways, a critical or supercritical mass would be likely to melt or possibly explode. It is necessary, therefore, that, before detonation, a nuclear weapon contain no piece of fissionable material as large as a critical mass. At the time of the detonation, some method must be employed to make the mass supercritical by changing its configuration. Two general methods have been developed for quickly converting a subcritical mass into a supercritical one.
- (1) In the first, two pieces of fissionable material, each less than a critical mass, are brought together very rapidly to form a single supercritical one. This gun-type assembly may be achieved in a tubular device in which a high explosive is used to blow one subcritical piece of fissionable material from one end of the tube into another subcritical piece held at the opposite end of the tube (Figure 2-VII).



*Figure 2-VII. Gun Assembly Principle*

- (2) In the second or implosion-type assembly method (see Figure 2-VIII), a subcritical mass of  $^{235}\text{U}$  or  $^{239}\text{Pu}$  is compressed to produce a mass capable of supporting a supercritical chain reaction. This compression is achieved by the detonation of specially designed high explosives surrounding a subcritical

sphere of fissionable material. When the high explosive is detonated, an inwardly directed implosion wave is produced. This wave compresses the sphere of fissionable material. The decrease in surface to volume ratio of this compressed mass plus its increased density is then such as to make the mass supercritical. An enhanced radiation (ER) weapon, by special design techniques, has an output in which neutrons and x-rays are made to constitute a substantial portion of the total energy released. For example, a standard fission weapon's total energy output would be partitioned as follows: 50% as blast; 35% as thermal energy; and 15% as nuclear radiation. An ER weapon's total energy would be partitioned as follows: 30% as blast; 20% as thermal; and 50% as nuclear radiation. Thus, a 3-kiloton ER weapon will produce the nuclear radiation of a 10-kiloton fission weapon and the blast and thermal radiation of a 1-kiloton fission device (Figure 2-IX). However, the energy distribution percentages of nuclear weapons are a function of yield.

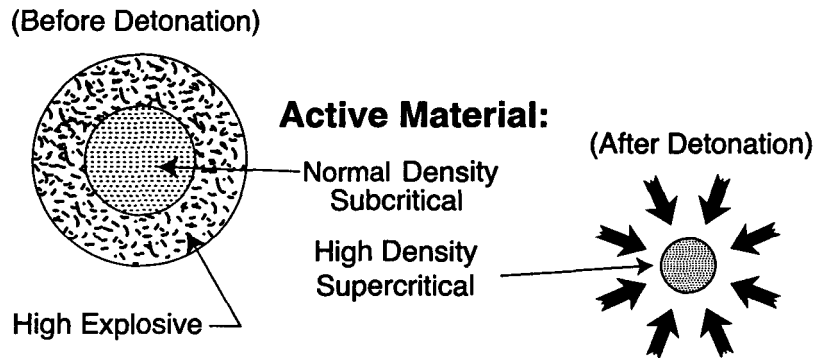


Figure 2-VIII. Implosion Assembly Principle

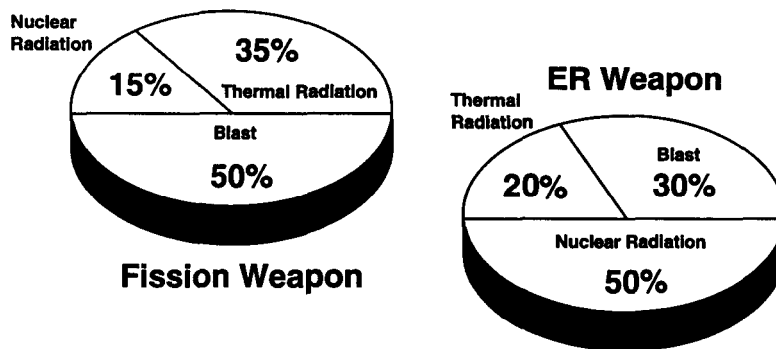


Figure 2-IX. Weapon Energy Distribution

## 211. Fusion.

In general, fusion may be regarded as the opposite of fission. It is the combining of two light nuclei to form a heavier nucleus. For the fusion process to take place, two nuclei must be forced together by enough energy so that the strong, attractive, short-range, nuclear forces overcome the electrostatic forces of repulsion. The two conditions necessary for the fusion of appreciable numbers of nuclei are high temperatures to accelerate the nuclei and high pressure density to increase the probability of interaction. The only practical way to obtain the temperatures and pressures required is by means of a fission explosion. Consequently, weapons with fusion components must contain a basic fission component. The energy released in the explosion of a fission-fusion weapon originates in approximately equal amounts from the fission and fusion processes.

## SECTION III - RADIOACTIVITY AND NUCLEAR RADIATION

### 212. General.

Paragraph 208c. described the isotope  $^{235}\text{U}$  as being "... the naturally occurring, readily fissionable isotope of uranium..." An expanded, but more complete, description would also have identified the isotope  $^{235}\text{U}$  as being radioactive. Similarly, in a fission reaction most, if not all, of the fission products produced are radioactive.

### 213. Radioactivity.

The nuclei of certain naturally occurring isotopes, and of others produced artificially, contain excess energy, i.e., they are unstable. To attain stability, nuclei with excess energy emit that energy in the form of nuclear, ionizing radiation and, in that process, frequently change into different elements. (See paragraph 215e.) (Ionizing radiation is defined as radiation capable of removing an electron from a target atom or molecule, forming an ion pair.) Isotopes, the nuclei of which emit ionizing radiations to achieve stability, are termed radioactive. Radioactive isotopes are referred to as radioisotopes or radionuclides.

- a. *Radioactive Decay.* The process wherein radionuclides emit ionizing radiation is also termed radioactive decay. Each radioisotope has its own characteristic decay scheme. A decay scheme identifies the type or types ionizing radiation emitted; the range of energies of the radiation emitted; and the decaying radioisotope's half-life.
- b. *Half-Life.* Half-life is defined as the time required for half of the atoms of a given sample of radioisotope to decay. Half-life values range from fractions of a millionth of a second to billions of years. Theoretically, no matter how many half-lives have passed, some small number of nuclei would remain. However, since any given sample of radioactive material contains a finite number of atoms, it is possible for all of the atoms eventually to decay.
- c. *Data Plotting.* Radioactive decay may be plotted in a linear form as shown in Figure 2-X or in a semilogarithmic form as in Figure 2-XI. The latter has the advantage of being a straight lineplot. The straight line form is used extensively in radiation physics, particularly when dealing with isotopes with short half-lives, since it allows

direct determination by simple inspection of the activity at any given time with a precision adequate for most purposes.

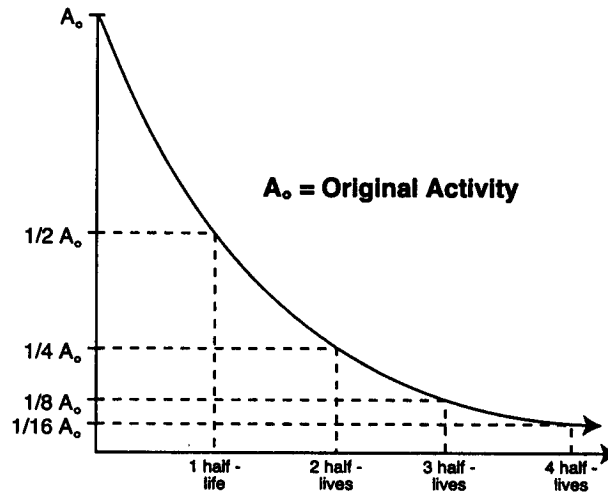


Figure 2-X. Radioactive Decay Plotted in Linear Form

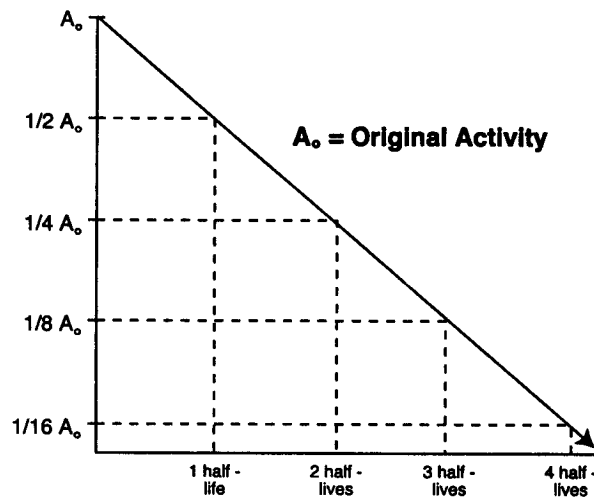


Figure 2-XI. Radioactive Decay Plotted in Semilogarithmic Form

**214. Measurement of Radioactivity.**

- a. The international system of units is based on the meter, kilogram, and the second as units of length, mass, and time, and is known as Systems International (SI). The

amount of radioactivity in a given sample of radioisotope is expressed by the new Systems International (SI) unit of the Becquerel (Bq). The old unit was the Curie (Ci). One Becquerel of a radioisotope is the exact quantity that produces one disintegration per second. The Curie is  $3.7 \times 10^{10}$  disintegrations per second. Thus  $1 \text{ Bq} = 2.7 \times 10^{-11} \text{ Ci}$  and  $1 \text{ Ci} = 3.7 \times 10^{10} \text{ Bq}$ . As the Becquerel is inconveniently small for many uses as was the Curie inconveniently large, prefixes such as micro ( $\mu$ ) ( $10^{-6}$ ), milli (m) ( $10^{-3}$ ), kilo (k) ( $10^3$ ), mega (M) ( $10^6$ ), and giga (G) ( $10^9$ ) are routinely used. Following nuclear detonations, the amounts of radioactive material produced are very large and the terms petas-becquerel (PBq) ( $10^{15} \text{ Bq}$ ) and exabecquerel (EBq) ( $10^{18} \text{ Bq}$ ) may be used. The term megacurie (MCi) ( $10^6 \text{ Ci}$ ) used to be used.

- b. The amount of radioactive material available at any time can be calculated by using a specific mathematical formula:

$$A_t = A_0 e^{(-\lambda t)}$$

from which the following can be derived:

$$A_t = A_0 e^{\left(\frac{-0.693t}{T_{1/2}}\right)}$$

since

$$\lambda = \frac{-0.693}{T_{1/2}}$$

- c. The terms in these formulae are as follows:

- (1)  $A_t$  = activity remaining after a time interval, t.
- (2)  $A_0$  = activity of sample at some original time.
- (3) e = base of natural logarithms (2.718...).
- (4)  $\lambda$  = decay constant of the particular isotope, derived from the half-life.
- (5) t = elapsed time.
- (6)  $T_{1/2}$  = half-life of the particular isotope.

- d. This formula can be used to calculate the activity (A) of an isotope after a specific time interval (t) if the half-life ( $T_{1/2}$ ) and the original activity ( $A_0$ ) are known.

- (1) Example: If  $3.7 \times 10^{10} \text{ Bq}$  (= 1.0 Ci) of  $^{60}\text{Co}$  (cobalt) is the original amount of radioactive material at time  $t_0$ , what will be the activity of the  $^{60}\text{Co}$  remaining 1 month later?

$A_{1 \text{ month}}$  = activity remaining after 1 month (t)

$A_0 = 3.7 \times 10^{10} \text{ Bq}$  (original activity)

$T_{1/2} = 5.27$  years (half-life of  $^{60}\text{Co}$  is 5.27 years)

t = 1 month (time elapsed since the original time).

(2) Substituting in the formula gives the following:

$$A_{1\text{ month}} = 3.7 \times 10^{10} \text{Bq} e^{\left(\frac{0.693t}{5.27\text{yr}} \times 1\text{ month}\right)}$$

(3) All values have to be converted to the same time units, in this case, years.  
Therefore:

$$\begin{aligned} A_{.0833\text{yr}} &= 3.7 \times 10^{10} \text{Bq} e^{\left(\frac{0.693t}{5.27\text{yr}} \times .0833\text{yr}\right)} \\ &= 3.7 \times 10^{10} \text{Bq} e^{\left(\frac{0.0577}{5.27\text{yr}}\right)} \\ &= 3.7 \times 10^{10} \text{Bq} e^{(-0.0109)} \\ &= 3.7 \times 10^{10} \text{Bq} e^{0.99} \end{aligned}$$

(4) In other words, the activity of  $^{60}\text{Co}$  after 1 month is 0.99 of its original activity, a reduction of only 1%. This could not be determined with precision from a graphic plot of activity versus time.

## 215. Nuclear Radiation.

Radioisotopes of heavy elements such as radium or uranium characteristically decay by emission of ionizing radiation in the form of alpha particles. Some heavy elements also decay by spontaneous fission which results in neutron releases. For the lighter elements, emission of beta particles is common. In addition, emissions of gamma or x-ray photons almost invariably accompany both alpha and beta particle radiation. This is important since gamma or x radiation constitutes the principal casualty producing form of ionizing electromagnetic radiation associated with nuclear explosions. X-ray and gamma photons are essentially identical, differing only in their points of origin. Gamma photons originate in the nuclei of decaying atoms while x-rays originate in the electron shells surrounding nuclei. Refer to paragraphs 503-506 for detail of penetration capabilities of the types of radiation.

- a. Even though they possess no net electrical charge, gamma and x-ray photons interact with atoms to produce ionization. Gamma photons have discrete energies over a very wide range, but are considerably less ionizing than alpha or beta particles but much more penetrating.
- b. An alpha particle is a helium nucleus consisting of two protons and two neutrons all strongly bound together by nuclear forces. Alpha particles have a mass about 7000 times that of electrons and are ejected from the nuclei of radioactive atoms with one, or at the most several, characteristic and discrete energies. Although highly ionizing, alpha particles are only slightly penetrating.
- c. Beta particle decay involves the conversion of a neutron into a proton and electron

within the nucleus. While the proton is retained in the nucleus, the beta particle (electron) is ejected with a velocity dependent upon its kinetic energy. Opposed to alpha particles, beta particles show a continuous energy spectrum. Because of its smaller mass and relatively higher emission energies, a beta particle is less ionizing than an alpha particle but more penetrating.

- d. In a fission process, neutrons are also released and consequently, makeup a significant portion of the total radiation output.
- e. From the discussion in paragraphs 215b and 215c, it can be seen that, depending upon the type of particulate radiation emitted in decay, decaying nuclei can, in addition to changing their energy states, be transformed into new elements. Examples of the transformations resulting from alpha and beta particle decay are shown in Table 2-I.

*Table 2-1. Radioactive Decay*

Isotope	Half-Life	Radiations Emitted	Decay Product	Half-Life
<b>a. Fissionable Material</b>				
Uranium-235	7.1 x 10 <sup>8</sup> yr	$\alpha$ , $\gamma$	Thorium-231*	25.2 hr
Uranium-238	4.5 x 10 <sup>9</sup> yr	$\alpha$ , $\gamma$	Thorium-234*	24 days
Plutonium-239	2.4 x 10 <sup>4</sup> yr	$\alpha$ , $\gamma$	Uranium-235*	7.1 x 10 <sup>8</sup> yr
<b>b. Fission Products</b>				
Lanthanum-140	40 hr	$\beta^-$ , $\gamma$	Cerium-140	Stable
Iodine-131	8 days	$\beta^-$ , $\gamma$	Xenon-131m	11.9 days
Strontium-90	28.9 yr	$\beta^-$	Yttrium-90	64 hr
Cesium-137	30.0 yr	$\beta^-$ , $\gamma$	Barium-137m	2.5 min
<b>c. Other Radioisotopes</b>				
Radon-222	3.8 days	$\alpha$ , $\gamma$	Polonium-218*	3 min
Potassium-40	1.3 x 10 <sup>9</sup> yr	$\beta^-$ , $\beta^+$ , $\gamma$	Cesium-40 or Argon-40	Stable Stable
Sodium-24	15 hr	$\beta^-$ , $\gamma$	Magnesium-24	Stable
Hydrogen-3 (Tritium)	12.3 yr	$\beta^-$	Helium-3	Stable
* Includes other daughter radionuclides.				

## 216. Interaction With Matter.

- a. Ionizing radiation interacts with matter in one of two ways. It is either scattered or absorbed. Both result in deposition of energy in the target system. The mechanisms of absorption are of particular interest because:
  - (1) Absorption in body tissue may result in physiological injury.
  - (2) Absorption is a phenomenon upon which the detection of ionizing radiation is based.

- (3) The degree of absorption or type of interaction is a primary factor in determining shielding requirements.
- b. Transfer of energy from an incident photon or particle to the atoms of an absorbing target material may occur by several mechanisms.
- (1) *Excitation.* This process involves the addition of energy to an atomic or molecular system, thereby transferring it from its ground or stable state to an excited or unstable state. Depending upon the type of interaction, either the atomic nucleus or one of its orbital electrons may absorb the excitation energy.
    - (a) Electron excitation occurs when relatively small amounts of energy are transferred. Here the electrons may only be moved to a higher energy level in the atom (Figure 2-XII).
    - (b) An excited electron will not retain its energy but will tend to return to its original energy level either by emitting the excess energy in the form of a photon of electromagnetic radiation (x-ray) or by transferring its energy to the electrons of other atoms or molecules.
  - (2) *Ionization.* As indicated previously, ionization is any process which results in the removal of an electron (negative charge) from an atom or molecule thereby leaving the atom or molecule with a net positive charge. Ionization occurs if alpha or beta particles, or gamma photons transfer sufficient energy to dislodge one of the electrons from the outer orbital shells of the target atom. Each ionization event produces an ion pair consisting of a free electron and the positively charged remainder of the atom (Figure 2-XIII).

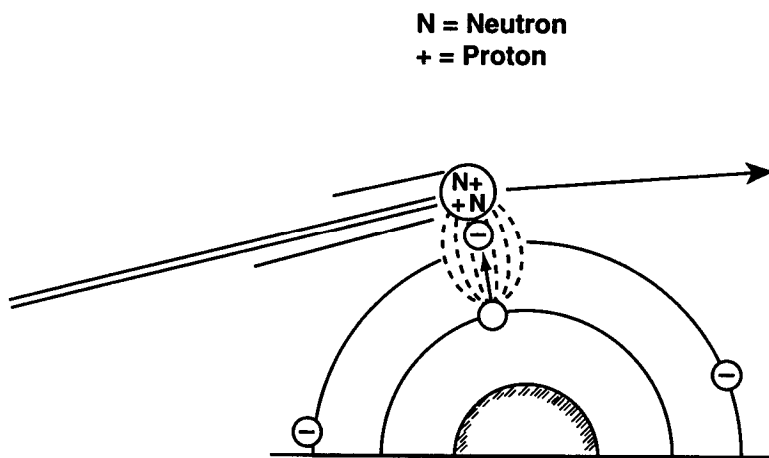


Figure 2-XII. Excitation of an Electron



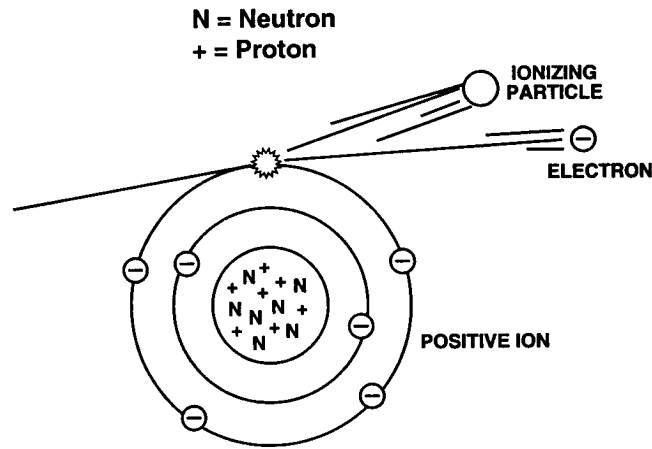


Figure 2-XIII. Electron Removal by Ionization

**217. Gamma Interaction.**

In terms of ionization, gamma radiation interacts with matter via three main processes: photoelectric effect, Compton scattering, and pair production.

- a. *Photoelectric Effect.* This describes the case in which a gamma photon interacts with and transfers all of its energy to an orbiting electron, ejecting that electron from the atom (Figure 2-XIV). The kinetic energy of the resulting photoelectron is equal to the energy of the incident gamma photon minus the binding energy of the electron. The photoelectric effect is thought to be the dominant energy transfer mechanism for x-ray and gamma ray photons with energies below 50 keV (thousand electron volts), but it is much less important at higher energies.

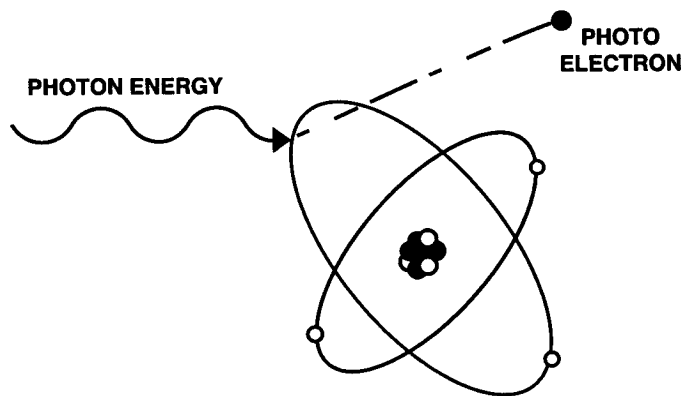


Figure 2-XIV. Gamma Interaction by Photoelectric Effect

- b. *Compton Scattering.* This is an interaction in which an incident gamma photon loses enough energy to an orbital electron to cause its ejection, with the remainder of the original photon's energy being emitted as a new, lower energy gamma photon with an emission direction different from that of the incident gamma photon (Figure 2-XV). The probability of Compton scatter decreases with increasing photon energy. Compton scattering is thought to be the principal absorption mechanism for gamma rays in the intermediate energy range 100 keV to 10 MeV (million electron volts), an energy spectrum which includes most gamma radiation present in a nuclear explosion. Compton scattering is relatively independent of the atomic number of the absorbing material.

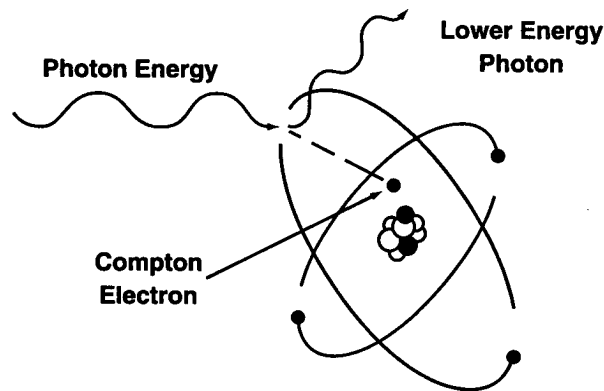
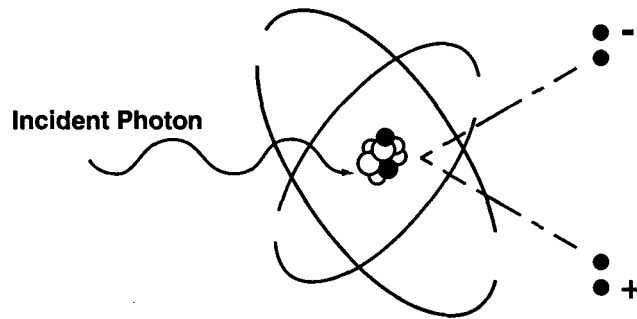


Figure 2-XV. Gamma Interaction by Compton Scattering

- c. *Pair Production.* By interaction in the vicinity of the coulomb force of the nucleus, the energy of the incident photon is spontaneously converted into the mass of an electron-positron pair. A positron is a positively charged electron. Energy in excess of the equivalent rest mass of the two particles (1.02 MeV) appears as the kinetic energy of the pair and the recoil nucleus. The electron of the pair, frequently referred to as the secondary electron, is densely ionizing. The positron has a very short lifetime. It combines with  $10^{-8}$  seconds with a free electron. The entire mass of these two particles is then converted to two gamma photons of 0.51 MeV energy each (Figure 2-XVI).



*Figure 2-XVI. Gamma Interaction by Pair Production*

## 218. Interaction of Charged Particles.

- a. Due to the high probability of interaction between an alpha particle and orbital electrons in an absorbing medium, a large number of ion pairs are formed per unit path length. Since a finite fraction of the total kinetic energy of an alpha particle is absorbed with the formation of each ion pair, the alpha particle will lose its energy over a relatively short distance. For these reasons, the range of alpha particles is much less than the range of beta particles or gamma photons.
- b. Beta particles and orbital electrons have negative charges, resulting in electrostatic repulsion when in the vicinity of one another. But, a beta particle has a charge opposite to that of the atomic nucleus, resulting in electrostatic attraction. Normally a beta particle loses its energy in a large number of ionization and excitation events in a manner analogous to the alpha particle. However, the range of the beta particle is considerably greater than that of an alpha particle. The beta particle travels longer distances between interactions and follows a “drunken man’s path” through matter.

## 219. Specific Ionization.

- a. The penetrating ability of radiation depends on the rate at which the radiation deposits energy along its path. The term specific ionization, which is defined as the average number of ion pairs generated per unit length of path, is used to describe the ionizing capability of ionizing radiations.
- b. Generally speaking, the ion density along the path of a low-energy particle is greater than that along the path of a high-energy particle of the same mass and charge. This is because the low-energy particle is moving slower and has more time to interact. Its total pathway is shorter, however, and the total number of interactions may well be less. Likewise, the ion density towards the end of the path of a particle is greater than at the beginning, because its velocity is less and the probability of interaction is increased accordingly. Alpha particles are capable of producing the highest specific ionization followed in order by beta particles and the secondary electrons produced by gamma-photon interactions (Table 2-II).

*Table 2-II. Specific Ionization of Radiation*

Radiation	Range in air	Speeds	Specific ionization
Alpha	5 - 7 cm	3,200 - 32,000 km/sec	20,000 - 50,000 ion pairs/cm
Beta	200 - 800 cm	25 - 99% speed of light	50 - 500 ion pairs/cm
Gamma	Use of half-thickness	Speed of light 300,000 km/sec	5 - 8 ion pairs/cm

- c. The more common basis for comparing the various types of radiations is known as Linear Energy Transfer (LET), and represents the average energy released (or lost) per unit track length in ionization and excitation interactions. LET is usually expressed in units of KeV (thousands of electron volts) per micron of path length. To a considerable extent, the Relative Biological Effectiveness (RBE) of various radiations depends on the rate of energy loss (LET) along the paths of the individual ionizing particles or photons. Radiations with low LET such as x- or gamma rays produce diffuse ionizations throughout the medium. In contrast, the LET associated with neutrons or alpha particles is so high that the passage of a single track will, in all probability, put enough ionizations into a traversed cell to produce death.

## 220. Stopping Power.

The maximum ranges of ionizing radiation in matter depend not only on the characteristics of the specific particles or photons but also on the stopping power of the absorbing material. The stopping power of a material is a function of electron density or the number of electrons per unit volume of the substance and represents the total energy lost in collision and radiative interaction. The electron density increases as the density electrons per gram ( $10^{23}$ ). Materials differ in their stopping power on the basis of the ratio of their atomic number to their atomic mass ( $Z/A$ ) times the density of the material. The range of a charged particle in an absorbing material is inversely proportional to this ratio. For example, if the range of a given energy beta particle is 1 cm in water, its range in air would be much greater (about 10 m), and in iron much smaller (about 1 mm).

## 221. Half-Value Layer.

- a. The concept of stopping power is not generally used in connection with material interactions of either gamma photons or uncharged neutrons. Since high-energy radiation is in general more penetrating than low-energy radiation, the specification of half-value layer (HVL) is often a convenient method of characterizing the

penetrating quality of an energy spectrum. Half-value layer is defined as that absorber thickness which reduces a given radiation intensity to one-half of the incident value (Figure 2-XVII). Refer to Table 7-II for half-value layer thickness of common materials.

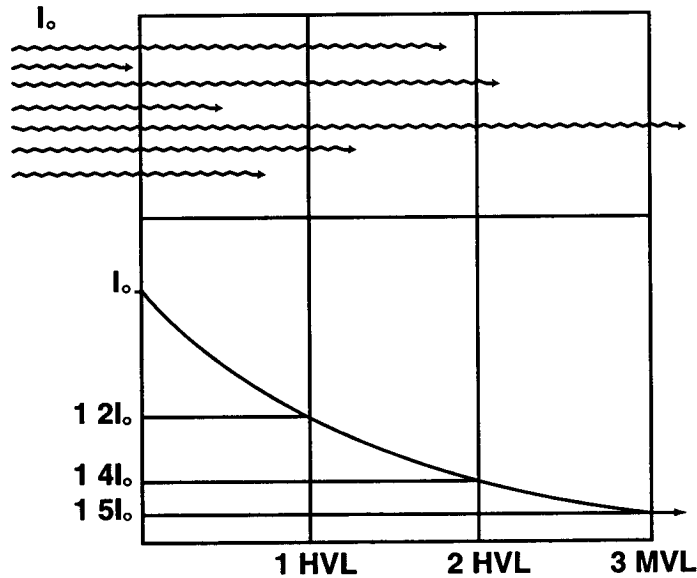


Figure 2-XVII. Attenuation of Gamma Radiation

- b. The relatively high penetrating power of x and gamma radiation compared with charged particles is related to the fact that the absorption interactions are fairly rare occurrences. The attenuation of gamma radiation as it passes through matter can be expressed by the following formula:

$$I = I_0 e^{-(\mu_0 d)}$$

where:

- (1)  $I$  = gamma radiation intensity after passing through a target material of thickness  $d$  (see below).
- (2)  $I_0$  = intensity of the incident gamma radiation at the surface of the target.
- (3)  $\mu_0$  = material-dependent attenuation coefficient ( $\text{cm}^{-1}$ ).
- (4)  $d$  = thickness of the target material (cm).

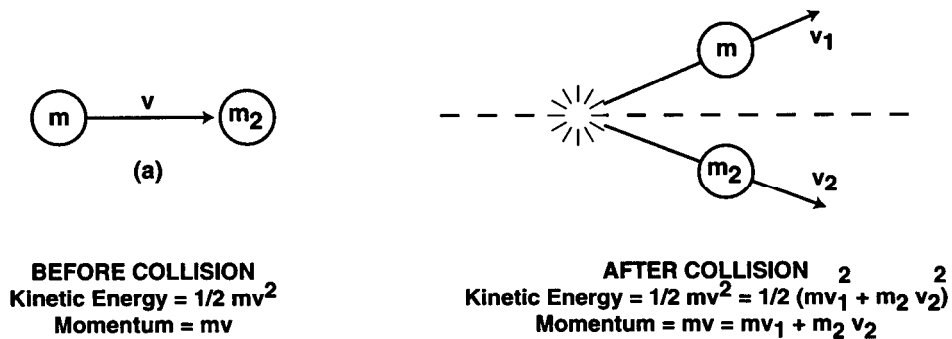
## 222. Neutron Interaction.

Although most ionizing radiation injuries associated with nuclear warfare will be attributable to gamma radiation previously described, a sufficient number of high-energy fission neutrons escape from the detonation to represent a significant hazard at considerable ranges.

- a. The neutron is a particle and thus is fundamentally different from electromagnetic radiation. It also differs from other particulate radiations (alpha and beta) in that neutrons do not carry any electrical charge. As a result, neutrons do not interact with the orbital electrons of atoms. Instead, they interact directly with the nuclei of atoms, particularly those having low atomic mass numbers.
- b. Depending on their point of origin, neutrons may have energies ranging from a fraction of an electron volt (eV) for so-called thermal neutrons to several megaelectron volts (MeV) for fast (fission) neutrons, to fusion neutrons which have energies of up to 14 MeV (e.g., deuterium-tritium reaction). Most neutrons produced in a nuclear fission detonation will have energies less than 1 MeV. A small fraction will have energies above 3 MeV. In enhanced radiation weapons, there will be a preponderance of 14 MeV neutrons.
- c. Neutrons transfer their energy to target atoms and molecules by elastic and inelastic collisions with nuclei.

**223. Elastic Collisions.**

In elastic collisions, part of the neutron's energy is transferred to the target atom in a manner analogous to a purely mechanical collision process (Figure 2-XVIII).



*Figure 2-XVIII. An Elastic Collision*

- a. Because the energy of a neutron is degraded by interactions with atomic nuclei, the probability of a neutron interacting with a target material does not depend on electron density as it does for other types of radiation. For fast neutrons, the probability of collision is practically the same for all nuclei. Since, in accordance with the laws of mechanics, considerably more energy is transferred in a collision between two objects of similar mass, neutrons will transfer more energy to target nuclei of substances of low atomic mass rather than to heavy nuclei. The lightest element is common hydrogen, <sup>1</sup>H, the nucleus of which contains a single proton. The mass of a proton is essentially the same as that of a neutron; and so, when a neutron collides with a hydrogen nucleus it can lose a considerable fraction of its

- energy in the interaction. Therefore, substances containing large quantities of hydrogen are good neutron moderators.
- b. The energy transfer mechanism with hydrogen accounts for more than 90% of the fast-neutron energy transfer up to 7 MeV occurring in wet, muscle-like tissue. The hydrogen nucleus then becomes ionized since it is accelerated away from its orbiting electron. An ion pair made up of the proton ( $H^+$ ) and the hydroxyl ion ( $OH^-$ ) is produced. The accelerated proton can, in turn, cause further secondary ionizations or excitations, spreading the damage of the original interaction. For neutrons with energies above 7 MeV, nuclear reactions with other tissue components become relatively important, but, even at 18 MeV, elastic scattering of protons constitutes about 70% of the energy absorbed in tissue.

## 224. Inelastic Collisions.

In inelastic collisions a neutron is captured by the target nucleus and a neutron of much lower energy is emitted leaving the target nucleus in an excited state. This energy is subsequently emitted in the form of electromagnetic radiation (Figure 2-XIX).

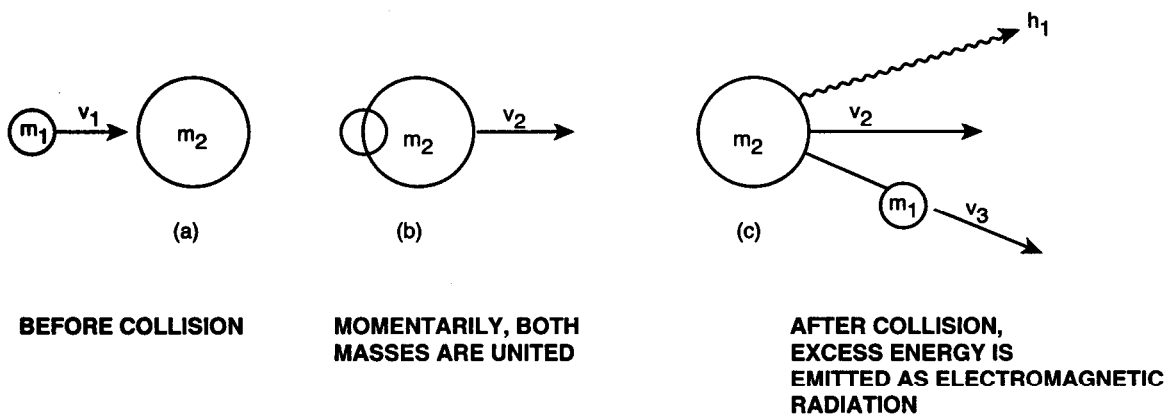


Figure 2-XIX. An Inelastic Collision

- a. Thus, in inelastic collisions or capture the incident neutron energy is absorbed entirely. Much of it appears as subsequent electromagnetic radiation which is high penetrating and can interact with the target at some other location. (See discussion on photon interactions.)
- b. Because the nucleus of an atom occupies so small a fraction of the total atomic volume, the probability of either elastic or inelastic scattering along a given neutron's path is very small. Even so, the energy transfer from an inelastic collision is significantly greater than that seen in the ionization or excitation interactions of gamma photons in tissue, and the penetrating ability of a fission-energy neutron is significantly less than that of gamma photons.
- c. A wide variety of interactions of neutrons with elements present in tissues is possible.

Incident neutrons of relatively low energy interact with and are captured by the nuclei of tissue elements, which become activated and emit a photon (gamma ray), which can penetrate over considerable distances prior to electron interactions. In interactions initiated by higher energy neutrons, the reaction products may have various energies depending on the energy level involved. Various biological materials have been used or suggested for measurements in connections with accidental exposure to neutrons.  $^{32}\text{P}$  activity in body hair has been employed in the evaluation of exposures to neutrons. Both blood and whole body measurements of  $^{24}\text{Na}$  activity are also important in the more accurate assessment of absorbed dose.

## 225. Neutron-to-Gamma Ratios.

- a. The total dose due to initial radiation from a nuclear weapon can be divided into two components, neutrons and gamma rays. The neutron-to-gamma ratio is the ratio of neutron dose to gamma dose present at a specified point. The neutron-to-gamma ratio for a given total dose level is dependent on weapon yield and design, air density, and height-of-burst (HOB). Some typical neutron-to-gamma ratio values for 2600 centigray (cGy) total dose to an unprotected individual are shown in Table 2-III.

*Table 2-III. Typical Neutron-to-Gamma and Neutron Dose-to-Total Dose Ratios\**

Yield (Kt)	n/g	n/n + g	Range
0.1	4.6	0.82	360 meters
1.0	3.0	0.75	650 meters
10.0	1.6	0.62	1040 meters
100.0	0.47	0.32	1500 meters
1000.0	0.042	0.04	2280 meters

\* Assumptions: HOB =  $60W^{1/3}$  meters, where W = yield in kilotons; air density is equal to 0.9, relative to sea level; fission only device; total dose is equal to 2600 cGy.

- b. As a general rule, the neutron-to-gamma ratio decreases with the range from the weapon's ground zero. This is due to the neutrons interacting with the air, creating secondary gamma. As a result, the gamma component decreases at a slower rate than does the neutron component. Thus, the ratios would be lower than the above values for a given yield at the 50-150 cGy dose levels because of the increased distance. These dose levels are typical of safety criteria. The ratios for vehicles and shelters depend on the specific neutron and gamma protection factors associated with the vehicle or shelter. These factors are based on the material used in construction. There are no typical ratios for vehicles, since each component of the ratio is effected differently by the associated radiation protection factor. However,



for a tank, the protection factors are about 2 and 10 for neutrons and gammas, respectively. In other words, the neutron component would be decreased by a factor of two. Therefore, at least for tanks, the gamma radiation is more effectively stopped. This will significantly effect the neutron-to-gamma ratio within the vehicle. In this case, the neutron-to-gamma ratio would increase.

## CHAPTER 3

## EFFECTS OF NUCLEAR EXPLOSIONS

## SECTION I - GENERAL

**301. Introduction.**

The basic differences in the mechanisms of energy production and related characteristics of conventional as compared with nuclear detonations were discussed in Chapter 2. In this chapter that discussion will be extended to consider the forms in which the energy produced in such detonations affects the surrounding environment. The location of the point of detonation in the environment is as important as the yield in determining the way the energy is distributed, and this factor will be discussed in some detail.

**302. General Effects of Nuclear Explosions.**

- a. While the destructive action of conventional explosions is due almost entirely to the transmission of energy in the form of a blast wave with resultant mechanical damage, the energy of a nuclear explosion is transferred to the surrounding medium in three distinct forms: blast; thermal radiation; and nuclear radiation. The distribution of energy among these three forms will depend on the yield of the weapon, the location of the burst, and the characteristics of the environment. For a low altitude atmospheric detonation of a moderate sized weapon in the kiloton range, the energy is distributed roughly as follows:
  - (1) 50% as blast;
  - (2) 35% as thermal radiation; made up of a wide range of the electromagnetic spectrum, including infrared, visible, and ultraviolet light and some soft x-ray emitted at the time of the explosion; and
  - (3) 15% as nuclear radiation; including 570 as initial ionizing radiation consisting chiefly of neutrons and gamma rays emitted within the first minute after detonation, and 10% as residual nuclear radiation. Residual nuclear radiation is the hazard in fallout.
- b. Considerable variation from this distribution will occur with changes in yield or location of the detonation. This is best shown by comparing the ranges of damage due to these effects of weapons of different size yields (Table 3-I).
- c. The distribution of weapon energy yield is altered significantly by the enhanced radiation nuclear warhead. In simplest terms an enhanced radiation warhead is designed specifically to reduce the percentage of energy that is dissipated as blast and heat with a consequent increase in the percentage yield of initial radiation. Approximate percentage energies are 30% blast; 20% thermal; 45% initial radiation; and 570 residual radiation.

*Table 3-1. Radii of Effects of Nuclear Weapons\**

Effect	1 Kt	10 Kt	100 Kt	1000 Kt
Ionizing radiation (50% immediate transient ineffectiveness)	600m	950m	1400m	2900m
Ionizing radiation (50% latent lethality)	800m	110m	1600m	3200m
Blast (50% casualties)	140m	360m	860m	3100m
Thermal radiation (50% casualties, second degree burns under fatigue uniform)	369m	110m	3190m	8020m

\* HOB 60W <sup>1/3</sup>

### 303. Initial Energy Transfer and Formation of Fireball.

- a. Because of the tremendous amounts of energy liberated per unit mass in a nuclear detonation, temperatures of several tens of million degrees centigrade develop in the immediate area of the detonation. This is in marked contrast to the few thousand degrees of a conventional explosion. At these very high temperatures the nonfissioned parts of the nuclear weapon are vaporized. The atoms do not release the energy as kinetic energy but release it in the form of large amounts of electromagnetic radiation. In an atmospheric detonation, this electromagnetic radiation, consisting chiefly of soft x-ray, is absorbed within a few meters of the point of detonation by the surrounding atmosphere, heating it to extremely high temperatures and forming a brilliantly hot sphere of air and gaseous weapon residues, the so-called fireball. Immediately upon formation, the fireball begins to grow rapidly and rise like a hot air balloon. Within a millisecond after detonation, the diameter of the fireball from a 1 megaton (Mt) air burst is 150 m. This increases to a maximum of 2200 m within 10 seconds, at which time the fireball is also rising at the rate of 100 m/sec. The initial rapid expansion of the fireball severely compresses the surrounding atmosphere, producing a powerful blast wave, discussed below.
- b. The fireball itself emits enormous amounts of electromagnetic radiation, similar in its spectrum to sunlight. This is usually termed thermal radiation. The visible light component accounts for the blinding flash seen upon detonation as well as the

subsequent brightness of the fireball, while the infrared component results in widespread burns and incendiary effects.

- c. As it expands toward its maximum diameter, the fireball cools, and after about a minute its temperature has decreased to such an extent that it no longer emits significant amounts of thermal radiation. The combination of the upward movement and the cooling of the fireball gives rise to the formation of the characteristic mushroom-shaped cloud. As the fireball cools, the vaporized materials in it condense to form a cloud of solid particles. Following an air burst, condensed droplets of water give it a typical white cloudlike appearance. In the case of a surface burst, this cloud will also contain large quantities of dirt and other debris which are vaporized when the fireball touches the earth's surface or are sucked up by the strong updrafts afterwards, giving the cloud a dirty brown appearance. The dirt and debris become contaminated with the radioisotopes generated by the explosion or activated by neutron radiation and fall to earth as fallout.
- d. The cloud rises for a period of approximately 10 minutes to a stabilized height which depends on the thermal output of the weapon and atmospheric conditions. It will continue to grow laterally assuming the familiar mushroom shape and may remain visible for an hour or more under favorable conditions. For example, the nuclear cloud from a 1 Mt surface burst will stabilize at an altitude of over 20 kilometers (km) and will have a mean lateral diameter of 35 km.

### 304. Types of Bursts.

The relative effects of blast, heat, and nuclear radiation will largely be determined by the altitude at which the weapon is detonated. Nuclear explosions are generally classified as air bursts, surface bursts, subsurface bursts, or high altitude bursts.

- a. *Air-Bursts.* An air burst is an explosion in which a weapon is detonated in air at an altitude below 30 km but at sufficient height that the fireball does not contact the surface of the earth. After such a burst, blast may cause considerable damage and injury. The altitude of an air burst can be varied to obtain maximum blast effects, maximum thermal effects, desired radiation effects, or a balanced combination of these effects. Burns to exposed skin may be produced over many square kilometers and eye injuries over a still larger area. Initial nuclear radiation will be a significant hazard with smaller weapons, but the fallout hazard can be ignored as there is essentially no local fallout from an air burst. The fission products are generally dispersed over a large area of the globe unless there is local rainfall resulting in localized fallout. In the vicinity of ground zero, there may be a small area of neutron-induced activity which could be hazardous to troops required to pass through the area. Tactically, air bursts are the most likely to be used against ground forces.
- b. *Surface Burst.* A surface burst is an explosion in which a weapon is detonated on or slightly above the surface of the earth so that the fireball actually touches the land or water surface. Under these conditions, the area affected by blast, thermal radiation, and initial nuclear radiation will be less extensive than for an air burst of similar yield, except in the region of ground zero where destruction is concentrated.

In contrast with air bursts, local fallout can be a hazard over a much larger downwind area than that which is affected by blast and thermal radiation.

- c. *Subsurface Burst.* A subsurface burst is an explosion in which the point of the detonation is beneath the surface of land or water. Cratering will generally result from an underground burst, just as for a surface burst. If the burst does not penetrate the surface, the only other hazard will be from ground or water shock. If the burst is shallow enough to penetrate the surface, blast, thermal, and initial nuclear radiation effects will be present, but will be less than for a surface burst of comparable yield. Local fallout will be very heavy if penetration occurs.
- d. *High Altitude Burst.* A high altitude burst is one in which the weapon is exploded at such an altitude (above 30 km) that initial soft x-rays generated by the detonation dissipate energy as heat in a much larger volume of air molecules. There the fireball is much larger and expands much more rapidly. The ionizing radiation from the high altitude burst can travel for hundreds of miles before being absorbed. Significant ionization of the upper atmosphere (ionosphere) can occur. Severe disruption in communications can occur following high altitude bursts. They also lead to generation of an intense electromagnetic pulse (EMP) which can significantly degrade performance of or destroy sophisticated electronic equipment. There are no known biological effects of EMP; however, indirect effects may result from failure of critical medical equipment.

## SECTION II - BLAST

### 305. Formation of Blast Wave.

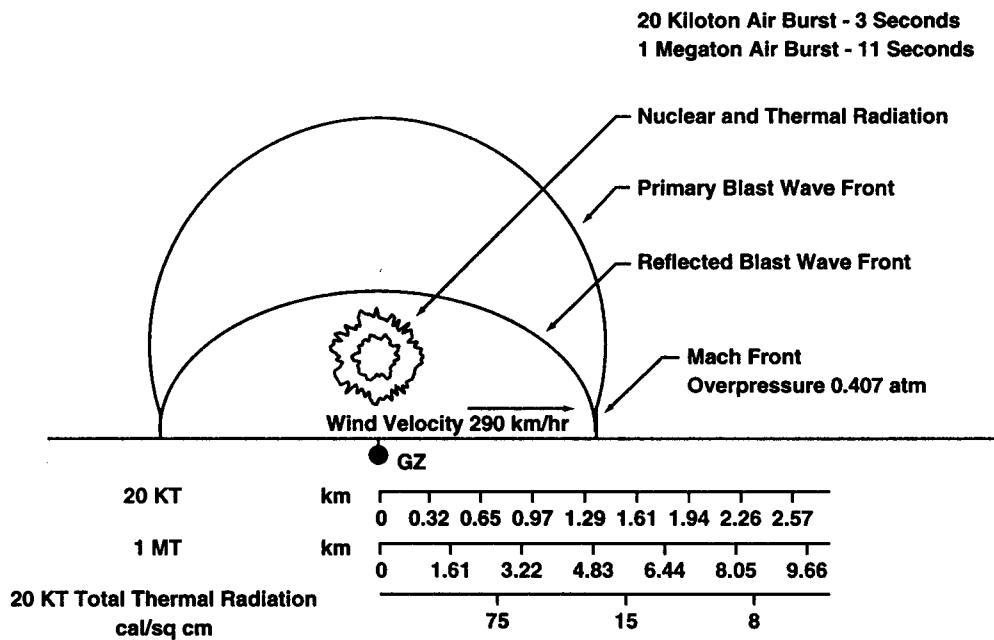
- a. As a result of the very high temperatures and pressures at the point of detonation, the hot gaseous residues move outward radially from the center of the explosion with very high velocities. Most of this material is contained within a relatively thin, dense shell known as the hydrodynamic front. Acting much like a piston that pushes against and compresses the surrounding medium, the front transfers energy to the atmosphere by impulse and generates a steep-fronted, spherically expanding blast or shock wave. At first, this shock wave lags behind the surface of the developing fireball. However, within a fraction of a second after detonation, the rate of expansion of the fireball decreases to such an extent that the shock catches up with and then begins to move ahead of the fireball. For a fraction of a second, the dense shock front will obscure the fireball, accounting for the characteristic double peak of light seen with a nuclear detonation.
- b. As it expands, the peak pressures of the blast wave diminish and the speed of propagation decreases from the initial supersonic velocity to that of sound in the transmitting medium. However, upon reflection from the earth's surface, the pressure in the wave will be reinforced by the fusion of the incident and the reflected wave (the Mach effect) described below.
- c. A large part of the destruction caused by a nuclear explosion is due to blast effects. Objects within the path of the blast wave are subjected to severe, sharp increases in atmospheric pressure and to extraordinarily severe transient winds. Most buildings,

with the exception of reinforced or blast-resistant structures, will suffer moderate to severe damage when subjected to overpressures of only 35.5 kiloPascals (kPa) (0.35 Atm). The velocity of the accompanying blast wind may exceed several hundred km/hr. Most materiel targets are drag- or wind-sensitive.

- d. The range for blast effects increases significantly with the explosive yield of the weapon. In a typical air burst, these values of overpressure and wind velocity noted above will prevail at a range of 0.7 km for 1 kiloton (Kt) yield; 3.2 km for 100Kt; and 15.0 km for 10 Mt.

**306. Propagation of Blast Wave in Air.**

During the time the blast wave is passing through the superheated atmosphere in the fireball, it travels at supersonic velocities. After it leaves the vicinity of the fireball, it slows down to the normal speed of sound in the atmosphere. As long as the blast wave is expanding radially, its intensity decreases approximately as the square of the distance. When the expanding blast wave from a nuclear air burst strikes the surface of the earth, however, it is reflected (Figure 3-I), and the reflected wave reinforces and intensifies the primary wave.



*Figure 3-I. Chronological Development of an Air Burst*

- a. Targets in the vicinity of ground zero may actually be subjected to two blast waves: the initial or incident wave, followed slightly later by a secondary reflected wave. This limited region close to ground zero in which the incident and reflected waves are separate is known as the region of regular reflection.

- b. Beyond the area of regular reflection as it travels through air which is already heated and compressed by the incident blast wave, the reflected wave will move much more rapidly and will very quickly catch up with the incident wave. The two then fuse to form a combined wave front known as the Mach stem. The height of the Mach stem increases as the blast wave moves outward and becomes a nearly vertical blast front. As a result, blast pressures on the surface will not decrease as the square of the distance, and most direct blast damage will be horizontally directed, e.g., on the walls of a building rather than on the roof.
- c. As the height of burst for an explosion of given yield is decreased, or as the yield of the explosion for a given height of burst is increased, Mach reflection commences nearer to ground zero and the overpressure near ground zero becomes larger. However, as the height of burst is decreased, the total area of coverage for blast effects is also markedly reduced. The choice of height of burst is largely dependent on the nature of the target. Relatively resistant targets require the concentrated blast of a low altitude or surface burst, while sensitive targets may be damaged by the less severe blast wave from an explosion at a higher altitude. In the latter case a larger area and, therefore, a larger number of targets can be damaged.
- d. A surface burst results in the highest possible overpressures near ground zero. In such a burst, the shock front is hemispherical in form, and essentially all objects are subjected to a blast front similar to that in the Mach region described above. A subsurface burst produces the least air blast, since most of the energy is dissipated in the formation of a crater and the production of a ground shock wave.

### 307. Static Overpressure and Dynamic Pressure.

- a. Two distinct though simultaneous phenomena are associated with the blast wave in air:
  - (1) Static overpressure, i.e., the sharp increases in pressure due to compression of the atmosphere. These pressures are those which are exerted by the dense wall of air that comprises the wave front. The magnitude of the overpressure at any given point is directly proportional to the density of the air in the wave.
  - (2) Dynamic pressures, i.e., drag forces exerted by the strong transient blast winds associated with the movement of air required to form the blast wave. These forces are termed dynamic because they tend to push, tumble, and tear apart objects and cause their violent displacement.
- b. In general, the static overpressure rises very abruptly from normal atmospheric in the unaffected air in front of the blast wave to a sharp peak (Figure 3-II). It then decreases behind the front. As the blast wave moves out from ground zero, the peak overpressure of the front diminishes while the decay of overpressure behind the front becomes more gradual. After traveling a sufficient distance from the fireball, the pressure behind the front actually drops below normal atmospheric pressure, the so-called negative phase of the blast wave.
- c. In passing through the atmosphere, the blast wave imparts its energy to the molecules of the surrounding air, setting them into motion in the direction of the advancing shock front. The motion of these air molecules is manifested as severe transient winds, known as "blast winds," which accompany the blast wave. The destructive

force associated with these winds is proportional to the square of their velocity and is measured in terms of dynamic pressure. These winds constitute decay forces which produce a large number of missiles and tumbling of objects. These dynamic forces are highly destructive.

- d. Most of the material damage caused by a nuclear air burst is caused by a combination of the high static overpressures and the dynamic or blast wind pressures. The relatively long duration of the compression phase of the blast wave (Figure 3-II) is also significant in that structures weakened by the initial impact of the wave front are literally torn apart by the forces and pressures which follow. The compression and drag force phases together may last several seconds or longer, during which forces many times greater than those in the strongest hurricane are present. These persist even through the negative phase of a blast wave when a partial vacuum is present because of the violent displacement of air.

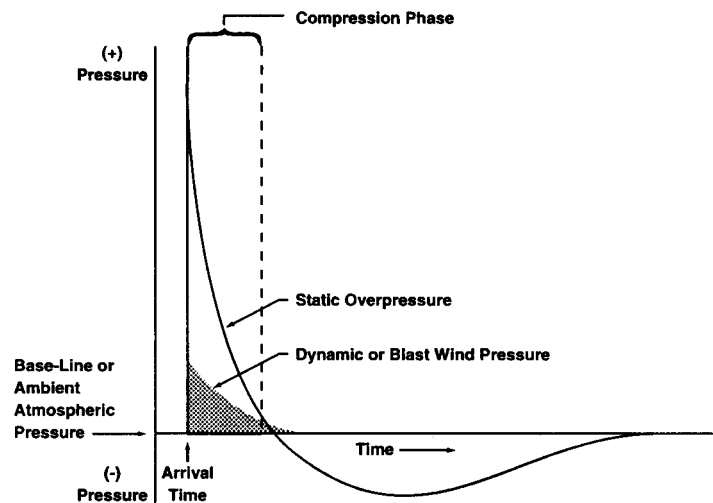


Figure 3-II. Variations of Overpressure and Dynamic Pressure with Time

- e. It is of practical value to examine the variation in pressure at a fixed location as a function of time. For a short period of time after a nuclear air burst, there will be no increase in pressure since it takes a finite time for the shock front to reach a given point. This arrival time, which may range from a few seconds to minutes, will depend primarily on the distance of the location from the center of burst and to a lesser extent on the yield of the explosion. Initially, the speed of the shock front is many times the speed of sound because it is traveling through superheated air, but as it travels away from the fireball it slows down to the speed of sound, 330 m/sec, in normal atmospheres. With high yield detonations, the early velocity of the shock front and the distance traveled through superheated air is greater. Therefore, time is somewhat less. Upon arrival of the shock front, both the static overpressure and the dynamic pressure increase almost immediately from zero to their maximum values.



The peak values of pressure will, of course, depend on the distance from ground zero, the height of burst, and the yield and will be further modified by differences in terrain and meteorological conditions. With passage of the blast front, both the static and dynamic pressures decay, though at slightly different rates. Most blast damage will be experienced during the positive or compression phase of the wave. The duration of this positive phase increases with yield and distance from ground zero and ranges from 0.2 to 0.5 sec for a 1 KT nuclear air burst to 4 to 10 sec for a 10 Mt explosion. This compares with only a few hundredths of a second for the duration of a blast wave from a conventional high-explosive detonation.

- f. Because of the much longer duration of the blast wave from a nuclear explosion, structures are subjected to maximum loading for correspondingly longer periods of time, and damage will be much more extensive for a given peak overpressure than might otherwise be expected. During the negative phase, which is generally of even longer duration, the static pressure will drop below normal atmospheric pressure and the blast winds will actually reverse direction and blow back towards ground zero. Damage sustained during the negative phase is generally minor, however, because the peak values of underpressure and wind velocity are relatively low. Blast effects associated with positive and negative phase pressures are shown in Figure 3-III.

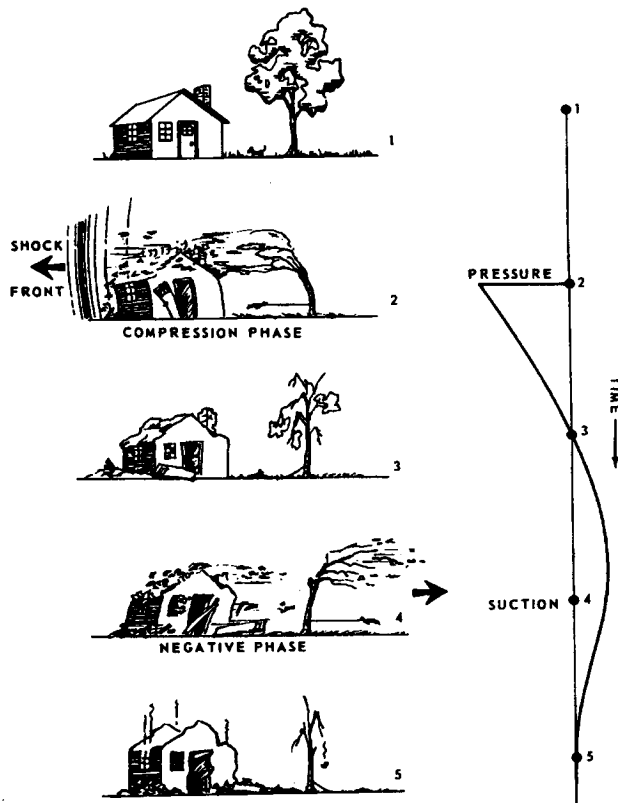


Figure 3-III. Variations of Blast Effects Associated with Positive and Negative Phase Pressures with Time

**308. Blast Loading.**

When a blast wave strikes the surface of a hard target, such as a building, the reflected wave will reinforce the incident wave, and the face of the building will be subjected to overpressures 2 to 8 times that of the incident wave alone. The severity of this additional stress depends on many factors, including the peak overpressure of the incident blast wave, as well as the angle at which the wave strikes the building. As the shock front advances, it bends or diffracts around the building, and the pressure on the front wall decreases rapidly. However, during the brief interval in which the blast wave has not yet engulfed the entire structure, a considerable pressure gradient exists from front to rear that places a severe stress on the building. For small objects, this period of so-called diffraction loading is so small that no significant stress is encountered. For large buildings, however, the stress of diffraction loading will be considerable. Even after the shock front has passed across the building, the structure will still be subjected to a severe compression force and to severe drag forces from the transient winds. The actual overpressures required to produce severe damage to diffraction sensitive targets are actually quite low. Table 3-II depicts failure of sensitive structural elements when exposed to overpressure blast loading.

*Table 3-II. Failure of Overpressure Sensitive Structural Elements*

Structural element	Failure	Approximate side-on peak overpressure (kPa)	Approximate slant range (km)	
			20 Kt	1 Kt
Glass windows, large and small	Shattering usually, occasional frame failure	3.45 - 6.9	6-10	20-30
Corrugated asbestos siding	Shattering	6.9 - 13.8	3-6	12-22
Corrugated steel or aluminum paneling	Connection failure followed by buckling	6.9 - 13.8	3-6	12-22
Brick wall panel, 20 cm or cm thick (not reinforced)	Shearing and flexure failures	20.7 - 69.0	1-3	4-10
Wood siding panels standard house construction	Usually failure occurs at the main connections, allowing a whole panel to be blown in	6.9 - 13.8	3-6	12-22
Concrete or cinder-block wall panels, 28 cm or 30 cm thick (not reinforced)	Shattering of the wall	10.35 - 38.0	1.5-4	6.5-15

### 309. Drag Loading.

All objects in the path of the blast wave, regardless of size or structure, will be subject to the dynamic pressure loading or drag forces of the blast winds. Drag loading is influenced to a moderate degree by the shape of the target. Round objects are relatively unaffected by the winds, while flat or recessed surfaces offer great resistance and hence are subjected to increased impact pressure and probability of damage. The effect of dynamic pressure is generally dependent on the peak value of dynamic pressure and its duration. While the dynamic pressure at the face of a building is generally less than the peak overpressure due to the blast wave and its reflection, the period of dynamic loading is much longer than that of diffraction loading, and hence the damage to frame-type buildings, bridges, and other structures will be considerable. Equipment and personnel are relatively resistant to static overpressures but highly vulnerable to dynamic pressure. For example, military vehicles, from jeeps to tanks, are most likely to suffer damage when pushed, overturned, and thrown about by the blast winds. Likewise, blast winds are the cause of most blast injuries. Because of the violence of the winds associated with even low values of overpressure, mechanical injuries due to missiles sent into motion by the winds or to violent bodily translation will far outnumber direct blast injuries due to actual compression of the organism.

### 310. Shock Waves in Other Media.

- a. In surface and subsurface bursts, a sizable portion of the yield is transmitted in the form of ground or water shock waves. In the case of a surface burst on land, a crater is formed at ground zero, the size of which depends primarily upon yield. Relatively little damage beyond a distance of approximately three crater radii will occur due to ground shock. Most damage will be due to the accompanying air blast wave. In subsurface bursts the crater will be formed either by ejection of material as in a shallow explosion or by the collapse of ground into the cavity formed by a deeper explosion. Since the overpressure in a ground shock wave decreases very rapidly with distance, shock damage will again be confined to a region close to the point of detonation.
- b. Ground shock waves will also be induced as a result of an air burst. If the overpressure in the blast wave is very large, the ground shock will penetrate some distance into the ground and may damage underground structures and buried utilities, etc.
- c. Because of the density and relative incompressibility of water, shock waves in that medium have very high peak overpressures and velocities of propagation. The peak overpressure at a distance of 1 km from a 10 Kt underwater burst is approximately 6080 kPa (60 atm (atmospheres of pressure)), while the peak overpressure in air at the same distance from an air burst is only 111.4 kPa (1.1 atm). The resulting surface waves at this distance will be approximately 10 m in height. The shock front will also travel at approximately five times the speed of the blast wave in air. Severe damage to naval vessels may result from the shock wave produced by an underwater or water surface burst. Although the major portion of the shock energy is propagated in the water, a significant amount is also transferred through the surface as a typical air blast. This blast wave could probably be the principal source of damage to land targets if the explosion occurred in a coastal area.

## SECTION III - THERMAL RADIATION

### 311. Formation of Thermal Radiation.

Large amounts of electromagnetic radiation in the visible, infrared, and ultraviolet regions of the electromagnetic spectrum are emitted from the surface of the fireball within the first minute or less after detonation. This thermal radiation travels outward from the fireball at the speed of light, 300,000 km/sec. The chief hazard of thermal radiation is the production of burns and eye injuries in exposed personnel. Such thermal injuries may occur even at distances where blast and initial nuclear radiation effects are minimal. Absorption of thermal radiation will also cause the ignition of combustible materials and may lead to fires which then spread rapidly among the debris left by the blast. The range of thermal effects increases markedly with weapon yield.

### 312. Propagation of Thermal Energy.

- a. Most of the energy released in the fission or fusion processes is initially in the form of the kinetic energy of the products of the reactions (e.g., fission fragments, etc.). Within millionths of a second after detonation, numerous inelastic collisions of these vaporized atoms give rise to a plasma of intensely hot weapon residues. Since the temperature of this system is of several tens of million degrees centigrade, it emits enormous quantities of energy in the form of electromagnetic radiation. This radiation is subsequently absorbed by the surrounding atmosphere, which is heated to extremely high temperatures, causing it to emit additional radiation of slightly lower energy. This complex process of radiative transfer of energy is the basic mechanism by which the fireball is formed and expands.
- b. Because this thermal radiation travels at the speed of light, and its mean free path (distance between point of emission and point of absorption) is relatively long, the initial expansion of the fireball is extremely rapid, much more so than the outward motion of gaseous material from the center of the burst responsible for production of the blast wave. Consequently, the blast wave front at first lags behind the radiative front (surface of the fireball).
- c. However, as the fireball expands and its energy is deposited in an ever-increasing volume its temperature decreases and the transfer of energy by thermal radiation becomes less rapid. At this point, the blast wave front begins to catch up with the surface of the fireball and then moves ahead of it, a process called hydrodynamic separation. Due to the tremendous compression of the atmosphere by the blast wave, the air in front of the fireball is heated to incandescence. Thus, after hydrodynamic separation, the fireball actually consists of two concentric regions: the hot inner core known as the isothermal sphere; and an outer layer of luminous shock-heated air.
- d. The outer layer initially absorbs much of the radiation from the isothermal sphere and hence the apparent surface temperature of the fireball and the amount of radiation emitted from it decreases after separation. But, as the shock front advances still farther, the temperature of the shocked air diminishes and it becomes increasingly transparent. This results in an unmasking of the still incandescent isothermal region

and an increase in the apparent surface temperature of the fireball. This phenomena is referred to as breakaway.

### 313. Rate of Thermal Emission.

- a. The rate of thermal emission from the fireball is governed by its apparent surface temperature. From the foregoing discussion, it should be apparent that the thermal output of a nuclear air burst will then occur in two pulses (Figure 3-IV), an initial pulse, consisting primarily of ultraviolet radiation, which contains only about 1% of the total radiant energy of the explosion and is terminated as the shock front moves ahead of the fireball, and a second pulse which occurs after breakaway.
- b. The thermal radiation emitted from the fireball surface during the second thermal pulse is responsible for most of the thermal effects. It consists chiefly of radiation in the infrared, visible, and ultraviolet regions of the electromagnetic spectrum. Thermal exposure (measured in joules per unit area of exposed surface) will be less farther from the center of the explosion because the radiation is spread over a greater area and is attenuated in passing through the intervening air. Since the fireball is very close to a point source of thermal radiation, the quantity of thermal radiation at any given point varies approximately with the square of the distance from the explosion. The inverse square law does not apply exactly because thermal radiation, particularly ultraviolet, will also be absorbed and scattered by the atmosphere. The degree of atmospheric visibility affects the attenuation of thermal energy with distance to a limited degree, but less than would be expected from the purely absorptive properties of the atmosphere, because the decrease in transmission is largely compensated by an increase in scattered radiation.

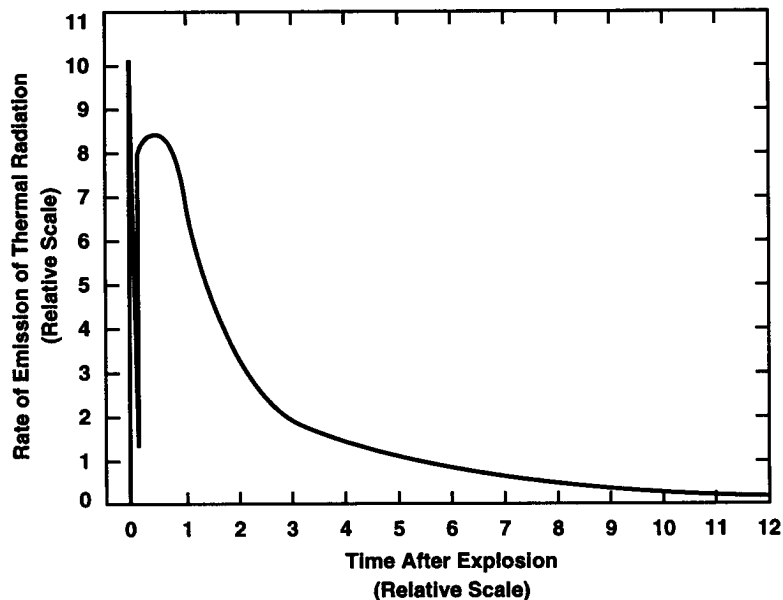


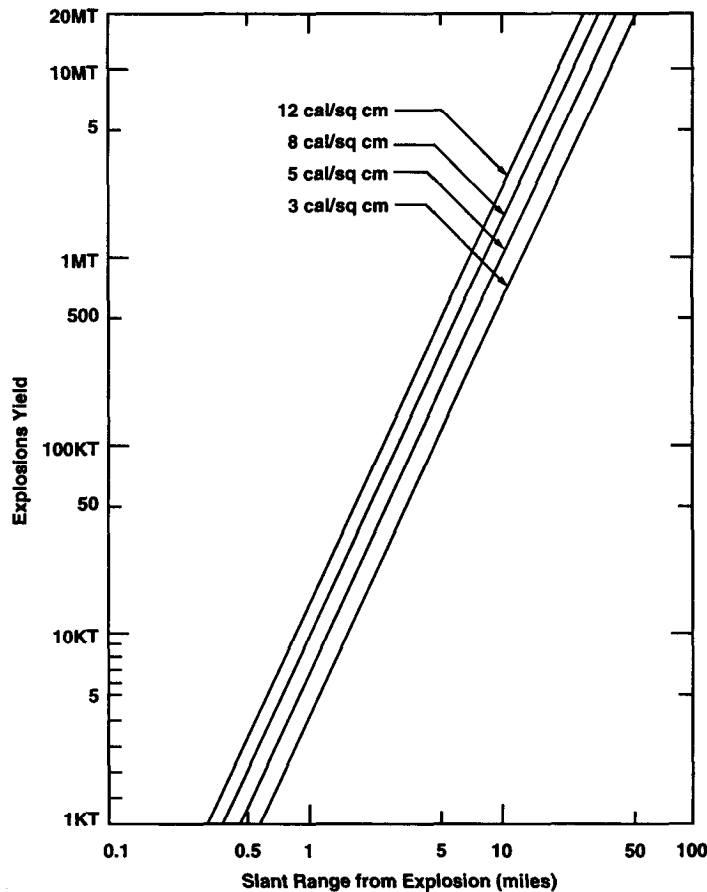
Figure 3-IV. Emission of Thermal Radiation in Two Pulses in an Air Blast

**314. Shielding.**

Since thermal radiation travels in straight lines from the fireball (unless scattered) any opaque object interposed between the fireball and the target will act as a shield and provide significant protection from thermal radiation. If a significant amount of scattering is present, as is the case when visibility is poor, thermal radiation will be received from all directions and shielding will be less effective.

**315. Yield and Altitude.**

- a. *Yield.* The total amount of thermal radiation, the period of time during which it is emitted, and the range for thermal effects increase with the yield of the nuclear explosion (Figure 3-V).



*Figure 3-V. Slant Ranges for Specified Radiant Exposures as Functions of Energy Yield of the Explosion*

- b. *Altitude Effects.* The thermal radiation intensity at a given point will depend on the altitude and the type of burst. In general, the thermal hazard is greatest in the case of a low altitude air burst. General thermal effects will be less for surface bursts and frequently nonexistent for subsurface bursts. In surface bursts a large part of the thermal energy is absorbed by the ground or water around ground zero. In addition, shielding due to terrain irregularities of dust, moisture, and various gases in the air near the surface of the earth will tend to reduce the amount of thermal energy reaching a target. In subsurface bursts without appreciable penetration, most of the thermal energy is absorbed and dissipated in heating and vaporizing soil and water below the surface.
- c. *High Altitude Effects.* In high altitude air bursts (above 30 km), the low density of the atmosphere alters the nature of the thermal radiation process because the primary thermal radiation is absorbed in a much larger volume of air, and the temperature of the system is correspondingly less. While a greater percentage of the yield of the explosion appears in the form of thermal radiation, much of the radiation is emitted so slowly that it is ineffective. About 25-35% of the total yield is emitted in a single pulse of very short duration. Moreover, because of the relatively great distance between the center of the burst and the earth's surface, the intensity of thermal radiation at ground level is generally low.

### 316. Thermal Effects.

- a. When thermal radiation strikes an object, part will be reflected, part will be transmitted, and the rest will be absorbed. The fraction of the incident radiation that is absorbed depends on the nature and color of the material. A thin material may transmit a large part of the radiant energy striking it. A light colored object may reflect much of the incident radiation and thus escape damage. Thermal damage and injury is due to the absorption of large amounts of thermal energy within relatively short periods of time. The absorbed thermal radiation raises the temperature of the absorbing surface and results in scorching, charring, and possible ignition of combustible organic materials, such as wood, paper, fabrics, etc. If the target material is a poor thermal conductor, the absorbed energy is largely confined to a superficial layer of the material.
- b. The radiation exposure (# Joules/sq/cm) required for the ignition of materials and other thermal effects increases with the yield of the weapon (Table 3-III). This is so because increased thermal energy is required to compensate for energy lost via conduction and convection during the longer thermal pulse of higher yield weapons. For lower yield weapons, the thermal pulse is so short that there is not much time for these processes to cool the exposed surface. Hence, a much higher percentage of the deposited thermal energy is effective in producing thermal damage. This increased thermal requirement does not mean that the thermal hazard is less significant for higher yields. On the contrary, the total thermal energy released during a nuclear explosion increases markedly with yield, and the effects extend over much greater distances. Therefore, although more thermal energy is required

- to produce a given thermal response for a large yield explosion, the effective range to which this level extends is very much greater.
- c. Actual ignition of materials exposed to thermal radiation is highly dependent on the width of the thermal pulse (which is dependent on weapon yield) and the nature of the material, particularly its thickness and moisture content. At locations close to ground zero where the radiant thermal exposure exceeds 125 Joules/sq cm, almost all ignitable materials will flame, although burning may not be sustained (Table 3-III). On the other hand, at greater distances only the most easily ignited materials will flame, although charring of exposed surfaces may occur. The probability of significant fires following a nuclear explosion depends on the density of ignition points, the availability and condition of combustible material (whether hot, dry, wet), wind, humidity, and the character of the surrounding area. Incendiary effects are compounded by secondary fires started by the blast wave effects such as from upset stoves and furnaces, broken gas lines, etc. In Hiroshima, a tremendous fire storm developed within 20 minutes after detonation. A fire storm burns in upon itself with great ferocity and is characterized by gale force winds blowing in towards the center of the fire from all points of the compass. It is not, however, a phenomenon peculiar to nuclear explosions, having been observed frequently in large forest fires and following incendiary raids during World War II.

#### SECTION IV - NUCLEAR RADIATION

##### 317. Sources of Nuclear Radiation.

Blast and thermal effects occur to some extent in all types of explosions, whether conventional or nuclear. The release of ionizing radiation, however, is a phenomenon unique to nuclear explosions and is an additional casualty producing mechanism superimposed on blast and thermal effects. This radiation is basically of two kinds, electromagnetic and particulate, and is emitted not only at the time of detonation (initial radiation) but also for long periods of time afterward (residual radiation). Initial or prompt nuclear radiation is that ionizing radiation emitted within the first minute after detonation and results almost entirely from the nuclear processes occurring at detonation. Residual radiation is defined as that radiation which is emitted later than 1 minute after detonation and arises principally from the decay of radioisotopes produced during the explosion.



Table 3-III. Approximate Radiant Exposures for Ignition of Fabrics for Low Air Burst\*

Material	Wt (g/m <sup>2</sup> )	Color	Effect on material	Ignition Exposure			
				35 kilotons ground		20 megatons ground	
				Joules sq cm	Range** (km)	Joules sq cm	Range** (km)
<b>a. Clothing Fabrics:</b>							
Cotton	298	White	Ignites	134	2.1	355	20.9
		Khaki	Tears on flexing	71	2.7	142	33.2
		Khaki	Ignites	84	2.5	163	30.9
		Olive	Tears on flexing	38	3.4	88	42.1
		Olive	Ignites	58	2.9	88	42.1
		Dk Blue	Tears on flexing	46	3.2	71	46.9
		Dk Blue	Ignites	58	2.9	88	42.1
Cotton corduroy	298	Brown	Ignites	46	3.2	92	41.2
Cotton denim, new	372	Blue	Ignites	50	3.1	184	29.1
Cotton shirting, new	112	Khaki	Ignites	58	2.9	117	36.5
Cotton-nylon mixture	186	Olive	Tears on flexing	33	3.6	71	46.9
		Olive	Ignites	50	3.1	222	26.5
Wool	298	White	Tears on flexing	58	2.9	109	37.9
		Khaki	Tears on flexing	58	2.9	142	33.2
		Olive	Tears on flexing	38	3.4	79	44.5
		Dk Blue	Tears on flexing	33	3.6	75	45.7
Rainware (double neoprene-coated)	335	Dk Blue	Tears on flexing	58	2.9	109	37.9
		Olive	Begins to melt	21	4.4	54	53.8
Nylon twill		Olive	Tears on flexing	33	3.6	92	41.2
<b>b. Drapery Fabrics:</b>							
Rayon gabardine	223	Black	Ignites	38	3.4	109	37.9
Rayon-acetate	186	Wine	Ignites	38	3.4	117	36.5
Rayon gabardine	260	Gold	Ignites	***		#117	36.5
Rayon twill lining	112	Black	Ignites	29	3.8	104	38.8
Rayon twill lining	112	Beige	Ignites	54	3.0	117	36.5
Acetate-sheeting	112	Black	Ignites	#42	3.3	#146	32.7
Cotton heavy drapes	484	Dark	Ignites	63	2.8	142	33.2
<b>c. Tent Fabrics:</b>							
Canvas (cotton)	446	White	Ignites	54	3.0	213	27.1
Canvas	446	O. Drab	Ignites	50	3.1	117	36.5
<b>d. Other Fabrics:</b>							
Cotton chenille bedspread		Lt Blue	Ignites	***		63	49.8
Cotton venetian blind tape, dirty		White	Ignites	42	3.3	92	41.2
Cotton venetian blind tape		White	Ignites	#54	3.0	#130	34.7
Cotton muslin window shade	298	Green	Ignites	29	3.8	79	44.5

\* Radiant exposures for indicated responses (except where marked#) are estimated valid to +25% under standard laboratory conditions. Under typical field conditions, values are estimated within +50% with a greater likelihood of the higher than lower values. For materials marked #, ignition levels are estimated to be valid within +50% under laboratory conditions and within 100% under field conditions.

\*\* Ground ranges calculated for good visibility conditions.

\*\*\* Data not available or appropriate scaling not known.

### 318. Initial Radiation.

About 5% of the energy released in a nuclear air burst is transmitted in the form of initial neutron and gamma radiation. The neutrons result almost exclusively from the energy producing fission and fusion reactions, while the initial gamma radiation includes that arising from these

reactions as well as that resulting from the decay of short-lived fission products. The intensity of initial nuclear radiation decreases rapidly with distance from the point of burst due to the spread of radiation over a larger area as it travels away from the explosion, and to absorption, scattering, and capture by the atmosphere. The character of the radiation received at a given location also varies with distance from the explosion. Near the point of the explosion, the neutron intensity is greater than the gamma intensity, but with increasing distance the neutron-gamma ratio decreases. Ultimately, the neutron component of initial radiation becomes negligible in comparison with the gamma component. The range for significant levels of initial radiation does not increase markedly with weapon yield and, as a result, the initial radiation becomes less of a hazard with increasing yield. With larger weapons, above 50 Kt, blast and thermal effects are so much greater in importance that prompt radiation effects can be ignored.

### 319. Residual Radiation.

The residual radiation hazard from a nuclear explosion is in the form of radioactive fallout and neutron-induced activity. Residual ionizing radiation arises from:

- a. *Fission Products.* These are intermediate weight isotopes which are formed when a heavy uranium or plutonium nucleus is split in a fission reaction. There are over 300 different fission products that may result from a fission reaction. Many of these are radioactive with widely differing half-lives. Some are very short, i.e., fractions of a second, while a few are long enough that the materials can be a hazard for months or years. Their principal mode of decay is by the emission of beta and gamma radiation. Approximately 60 grams of fission products are formed per kiloton of yield. The estimated activity of this quantity of fission products 1 minute after detonation is equal to that of  $1.1 \times 10^{21}$  Bq (30 million kilograms of radium) in equilibrium with its decay products.
- b. *Unfissioned Nuclear Material.* Nuclear weapons are relatively inefficient in their use of fissionable material, and much of the uranium and plutonium is dispersed by the explosion without undergoing fission. Such unfissioned nuclear material decays by the emission of alpha particles and is of relatively minor importance.
- c. *Neutron-Induced Activity.* If atomic nuclei capture neutrons when exposed to a flux of neutron radiation, they will, as a rule, become radioactive (neutron-induced activity) and then decay by emission of beta and gamma radiation over an extended period of time. Neutrons emitted as part of the initial nuclear radiation will cause activation of the weapon residues. In addition, atoms of environmental material, such as soil, air, and water, may be activated, depending on their composition and distance from the burst. For example, a small area around ground zero may become hazardous as a result of exposure of the minerals in the soil to initial neutron radiation. This is due principally to neutron capture by sodium (Na), manganese, aluminum, and silicon in the soil. This is a negligible hazard because of the limited area involved.

### 320. Fallout.

- a. *Worldwide Fallout.* After an air burst the fission products, unfissioned nuclear material, and weapon residues which have been vaporized by the heat of the fireball

will condense into a fine suspension of very small particles 0.01 to 20 micrometers in diameter. These particles may be quickly drawn up into the stratosphere, particularly so if the explosive yield exceeds 10 Kt. They will then be dispersed by atmospheric winds and will gradually settle to the earth's surface after weeks, months, and even years as worldwide fallout. The radiobiological hazard of worldwide fallout is essentially a long-term one due to the potential accumulation of long-lived radioisotopes, such as strontium-90 and cesium-137, in the body as a result of ingestion of foods which had incorporated these radioactive materials. This hazard is much less serious than those which are associated with local fallout and, therefore, is not discussed at length in this publication. Local fallout is of much greater immediate operational concern.

- b. *Local Fallout.* In a land or water surface burst, large amounts of earth or water will be vaporized by the heat of the fireball and drawn up into the radioactive cloud. This material will become radioactive when it condenses with fission products and other radiocontaminants or has become neutron-activated. There will be large amounts of particles of less than 0.1 micrometer to several millimeters in diameter generated in a surface burst in addition to the very fine particles which contribute to worldwide fallout. The larger particles will not rise into the stratosphere and consequently will settle to earth within about 24 hours as local fallout. Severe local fallout contamination can extend far beyond the blast and thermal effects, particularly in the case of high yield surface detonations. Whenever individuals remain in a radiologically contaminated area, such contamination will lead to an immediate external radiation exposure as well as a possible later internal hazard due to inhalation and ingestion of radiocontaminants. In severe cases of fallout contamination, lethal doses of external radiation may be incurred if protective or evasive measures are not undertaken. In cases of water surface (and shallow underwater) bursts, the particles tend to be rather lighter and smaller and so produce less local fallout but will extend over a greater area. The particles contain mostly sea salts with some water; these can have a cloud seeding affect causing local rainout and areas of high local fallout. For subsurface bursts, there is an additional phenomenon present called "base surge." The base surge is a cloud that rolls outward from the bottom of the column produced by a subsurface explosion. For underwater bursts the visible surge is, in effect, a cloud of liquid (water) droplets with the property of flowing almost as if it were a homogeneous fluid. After the water evaporates, an invisible base surge of small radioactive particles may persist. For subsurface land bursts, the surge is made up of small solid particles, but it still behaves like a fluid. A soil earth medium favors base surge formation in an underground burst.
- c. *Meteorological Effects.* Meteorological conditions will greatly influence fallout, particularly local fallout. Atmospheric winds are able to distribute fallout over large areas. For example, as a result of a surface burst of a 15 Mt thermonuclear device at Bikini Atoll on March 1, 1954, a roughly cigar-shaped area of the Pacific extending over 500 km downwind and varying in width to a maximum of 100 km was severely contaminated. Snow and rain, especially if they come from considerable heights, will accelerate local fallout. Under special meteorological conditions, such as a local rain shower that originates above the radioactive cloud, limited areas of heavy contamination may be formed.

## CHAPTER 4

## BIOLOGICAL EFFECTS OF A NUCLEAR EXPLOSION

## SECTION I - GENERAL

**401. Introduction.**

Chapter 3 described the physical characteristics of nuclear explosions. This chapter will consider the biological effects of blast and thermal radiation. The material to be presented is intended to supplement the material on the clinical aspects of blast and thermal injuries described in Chapter 6. The basic scientific aspects of radiation injury will be discussed in Chapter 5.

## SECTION II - BLAST INJURY

**402. General.**

- a. The basic physical effects of a blast wave are described in Chapter 3 along with how the wave is formed. There are two basic types of blast forces which occur simultaneously in a nuclear detonation blast wave. These are: direct blast wave overpressure forces, measured in terms of atmospheres of overpressure; and indirect blast wind drag forces, measured best in terms of the velocities of the wind which cause them. The most important blast effects, insofar as production of casualties requiring medical treatment is concerned, will be those due to the blast wind drag forces. Direct overpressure effects do not extend out as far from the point of detonation and are frequently masked by drag force effects as well as by thermal effects.
- b. However, direct blast effects can contribute significantly to the immediate deaths and injuries sustained close to the point of detonation and, therefore, do constitute an important total casualty producing effect in the large area of lethal damage associated with a given nuclear detonation. Personnel in fortifications or heavy vehicles such as tanks who are protected from radiation and thermal and blast wind effects may be subjected to complex patterns of direct overpressures since blast waves can enter such structures and be reflected and reinforced within them.

**403. Direct Blast Injury.**

- a. When a blast wave is incident upon a target, the nature and probability of damage will depend upon a number of variables in the characteristics of the blast wave and of the target. Important variables of the blast wave include: the rate of pressure rise at the blast wave front, the magnitude of the peak overpressure, and the duration of the blast wave. Those of the target include: size, mass, density, resistance to deformity, etc. If the target is human, then additional factors such as age, physical condition, and the presence of disease or other injury become important.

- b. When the blast wave acts directly upon a resilient target such as the human body, rapid compression and decompression result in transmission of pressure waves through the tissues. These waves can be quite severe and will result in damage primarily at junctions between tissues of different densities (bone and muscle) or at the interface between tissue and air spaces. Lung tissue and the gastrointestinal system, both of which contain air, are particularly susceptible to injury. The resulting tissue disruptions can lead to severe hemorrhage or to air embolism, either of which can be rapidly fatal. Perforation of the ear drums would be a common but a minor blast injury.
- c. The range of overpressures associated with lethality can be quite variable. It has been estimated that overpressures as low as 193 kPa (1.9 atm) can be lethal, but that survival is possible with overpressures as high as 262 kPa (2.5 atm). Atypical range of probability of lethality with variation in overpressure is summarized in Table 4-I. These are rough estimates based on selected experimental data, and there will be some differences between these figures and tabulations based upon other experimental work. In addition these numbers apply only to unreinforced, unreflected blast waves. When blast waves are complicated by reinforcement and reflection, estimation or measurement of the overpressures associated with specific injuries becomes quite complex. The significant thing shown by the data in Table 4-I is that the human body is remarkably resistant to static overpressure, particularly when compared with rigid structures such as buildings. Shattering of an unreinforced cinder block panel, for example, will occur at 10.1 -20.2 kPa (0.1-0.2 atm).

*Table 4-I. Range of Lethality at Peak Overpressure*

Lethality (approximate %)	Peak overpressure (k Pa)
1	160 - 230
50	230 - 400
100	400 +

- d. Overpressures considerably lower than those listed in Table 4-I will cause injuries which are not lethal. Lung damage and eardrum rupture are two useful biomedical parameters to use as examples, since one is a relatively serious injury, usually requiring hospitalization even if not lethal, while the other is a minor injury, often requiring no treatment at all.
- (1) The threshold level of overpressure which is estimated to cause lung damage is about 68.9 kPa for a simple unreinforced, unreflected blast wave. There will be considerable variation in this value with differing conditions of exposure.
  - (2) The threshold value for eardrum rupture is probably around 22 kPa (0.2 atm) and that overpressure associated with a 50% probability of eardrum rupture ranges from 90 to 130 kPa (0.9 to 1.2 atm).

- e. From this it can be seen that casualties requiring medical treatment from direct blast effects could theoretically be produced by overpressures greater than 70 kPa. However, direct blast injuries will not occur by themselves; and in general, other effects, such as indirect blast injuries and thermal injuries are so severe at the ranges associated with these overpressures that patients with direct blast injuries will comprise a very small part of the patient load.

#### 404. Indirect Blast Wind Drag Forces.

- a. *Blast Winds.* The drag forces of the blast winds are proportional to the velocities and duration times of those winds, which in turn vary with distance from the point of detonation, yield of the weapon, and altitude of the burst. These winds are relatively short in duration but are extremely severe. They can be much greater in velocity than the strongest hurricane winds and may reach several hundred kilometers per hour. Considerable injury can result, due either to missiles or to the physical displacement of human bodies against objects and structures in the environment.
- b. *Probability of Indirect Blast Injury.* The distance from the point of detonation at which severe indirect injury will occur is considerably greater than that for equally serious direct blast injuries. It is difficult to give precise ranges at which these indirect injuries are likely to occur because of the marked effect of variations in the environment. However, that range at which the peak overpressure is about 20.3 kPa (0.2 atm) is a reasonable reference distance at which the probability of serious indirect injury is high. Injuries can occur at greater ranges, and casualties will be generated at greater ranges, but not consistently.

#### 405. Missile Injury.

The probability of injury from a missile depends upon a number of factors.

- a. *The Number of Missiles.* The number of missiles which can be generated by the blast winds depends to some extent upon the environment. Certain terrain, such as desert, is particularly susceptible to missile forming effects of winds. However, the drag forces of the blast winds produced by nuclear detonations are so great that almost any form of vegetation or structure will be broken apart or fragmented into a variety of missiles. As a result, large numbers and a great variety of missiles will be generated in almost any environment. Single missile injuries will be rare and multiple, varied missile injuries will be common. As a result, the overall severity and significance of missile injuries is greatly increased. Table 4-II gives an indication of the ranges out to which significant missile injuries would be expected.
- b. *The Kinetic Energy and Shape of the Missiles.* Several separate factors are involved here, but a detailed discussion of complex missile ballistics is beyond the scope of this handbook. The major factor in how missiles are accelerated depends upon the wind velocity and the size and weight of the missiles. The wind velocity is the maximum, since objects cannot be made to go faster than the winds themselves. Therefore, all these missiles will be low velocity in nature. None will be high velocity, such as is produced with small arms fire. The weight or mass of an object

and the duration times of the winds determine whether or not that object will be accelerated maximally. Light objects will be accelerated rapidly up to the maximum possible velocity, whereas heavy objects may not be. The velocity is important because the probability of a penetrating injury increases with increasing velocity, particularly for small, sharp missiles such as glass fragments. Table 4-III shows typical experimental data for probability of penetration related to size and velocity of glass fragments of various weights. The table also lists the kinetic energy associated with each weight and velocity. The progression in energy is reversed, and it can be seen that heavier objects require higher kinetic energies to penetrate, at least in this particular experimental system. Heavy blunt missiles will not penetrate but can result in significant injury, particularly fractures. For example, a velocity of about 4.6 meters/see is a threshold velocity for skull fracture for a 4.5 kg missile.

*Table 4-II. Ranges for Different Probabilities of Injury from Small Missiles\**

Yield (Kt)	Range for 1% probability of serious injury	Range for 50% probability of serious injury	Range for 99% probability of serious injury
1	0.28 km	0.22 km	0.17 km
10	0.73 km	0.57 km	0.44 km
20	0.98 km	0.76 km	0.58 km
50	1.4 km	1.1 km	0.84 km
100	1.9 km	1.5 km	1.1 km
200	2.5 km	1.9 km	1.5 km
500	3.6 km	2.7 km	2.1 km
1000	4.8 km	3.6 km	2.7 km

\* Incidence of head injury based on incidence of perforation of skin and tissue. Missiles used were 10 gm in weight.

*Table 4-III. Probability of Penetration of Glass Fragments and Associated Kinetic Energy Related to Size and Velocity\**

Mass of glass fragments (grams)	1%	50%	99%
	Impact velocity (m/sec)**/Kinetic energy (joules)***		
0.1	78/0.3	136/0.9	243/3.0
0.5	53/0.7	91/2.1	161/6.5
1.0	46/1.1	82/3.4	143/10.2
10.0	38/7.2	60/18.0	118/70.0

\* The penetrating injury example here is for the abdominal cavity.  
 \*\* Impact velocity is in m/sec. Conversion to cm/sec is necessary to determine kinetic energy in joules.  
 \*\*\* Kinetic energy is expressed by  $1/2mv^2$ , in which m = mass in grams and v = velocity in cm/sec. The basic unit of kinetic energy is the erg, which is equivalent to  $gm^2/sec^2$ .

**406. Crush and Translational Injuries.**

The drag forces of the blast winds are strong enough to displace even large objects such as vehicles or to cause collapse of large structures such as buildings. These can result in very serious crush injuries. Humans themselves can become a missile and be displaced a variable distance and at variable velocities depending upon the intensity of the drag forces and the nature of the environment. The resulting injuries sustained are termed translational injuries. The probability and the severity of injury are functions of the velocity of the human body at the time of impact. If a representative displacement distance of 3.0 meters is assumed, the impact velocities which would be associated with various degrees of injury can be calculated. These are shown in Table 4-IV. The table shows terminal or impact velocities associated with significant but nonlethal blunt injury. It also shows those velocities which are associated with a probability of lethality. The velocities in Table 4-IV can be equated against yield, and the ranges at which such velocities would be found can be calculated. These are given in Table 4-V.

*Table 4-IV. Translational Injuries*

Velocity*(m/sec)	Probability of blunt injuries & fractures	Probability of fatal injuries
2.6	>1%	-
6.6	~50%	>1%
17.0	99%	~50%
44.5	-	99%

\*Velocities are based on solid impact with a nonyielding surface.

*Table 4-V. Ranges for Selected Impact Velocities of a 70-kg Human Body Displaced by Blast Wind Drag Forces for Different Yield Weapons*

Weapon yield (Kt)	Velocities*(m/sec)		
	2.6	6.6	17.0
1	0.38 km	0.27 km	0.19 km
10	1.0 km	0.75 km	0.53 km
20	1.3 km	0.99 km	0.71 km
50	1.9 km	1.4 km	1.0 km
100	2.5 km	1.9 km	1.4 km
200	3.2 km	2.5 km	1.9 km
500	4.6 km	3.6 km	2.7 km
1000	5.9 km	4.8 km	3.6 km

\* These velocities are selected from those listed in Table 4 -IV. Data account for ground friction and consider only prone personnel.



### SECTION III - THERMAL INJURY

#### 407. Mechanism of Injury.

The thermal radiation emitted by a nuclear detonation causes burns in two ways, by direct absorption of the thermal energy through exposed surfaces (flash burns) or by the indirect action of fires caused in the environment (flame burns). The relative importance of these two processes will depend upon the nature of the environment. If a nuclear weapon detonation occurs in easily flammable surroundings, indirect flame burns could possibly outnumber all other types of injury.

#### 408. Thermal Effects.

- a. Thermal radiation travels in a straight line from the fireball, and the amount of energy which is available to act upon a given target area decreases rapidly with distance. The thermal flux in watts per square centimeter decreases approximately with the square of the distance from the point of detonation. This attenuation with distance varies somewhat with the nature of the environment and the weather, since thermal radiation is easily reflected. However, the attenuating effect of even a heavy cloud cover is surprisingly small. Since thermal radiation travels in straight lines, objects between the fireball and any targets will tend to shield and protect them.
- b. Close to the fireball the thermal output will be so great that all objects will be incinerated. Immediate lethality obviously would be 100% within this range and to some extent beyond. The actual range out to which overall lethality would be 100% will vary with yield, position of burst, weather, the environment and how soon those burned can receive medical care. The mortality rate among the severely burned is much greater without early resuscitative treatment.

#### 409. Thermal Energy and Burns to Exposed Skin.

Two factors determine the degree of burn injury in a given situation. The amount of thermal energy per square centimeter and the duration of the thermal pulse. The dose of thermal radiation to exposed skin required to cause a flash second-degree burn will vary from less than 16.7 joules/cm<sup>2</sup> to more than 29.3 joules/cm<sup>2</sup> depending on the yield of the weapon (Table 4-VI). A larger dose is required with larger yield weapons because of the nature of the pulse. Megaton weapons have much longer thermal pulses with much more gradual rates of increase. There is time for the skin to dissipate some of the thermal energy; and therefore, more is required to produce a given degree of injury. However, it must be realized that the same degree of injury from a megaton weapon is seen at a much greater range and over a much greater area than would be the case with kiloton weapons. The difference in dose required to produce a given burn injury is not a significant factor when compared with the increase in overall probability of injury associated with increasing yield.

Table 4-VI. Factors for Determining Probability of Second-Degree Burns to Bare Skin

Yield of weapon	1 Kt	10 Kt	100Kt	1Mt	10 Mt
Range in kilometers for production of second-degree burns on exposed surfaces (air burst)*	0.78	2.1	4.8	9.1	14.5
Duration of thermal pulse (sec)**	0.2	0.6	1.6	4.4	12.0
Joules/cm <sup>2</sup> required to produce second-degree burns on exposed skin	16.7	18.8	22.1	26.3	29.3

\* Ranges calculated considering a 10-km visibility.  
 \*\* Time for delivery of 70% of thermal energy.

#### 410. Flash Burns Under Clothing.

While most thermal injury predictions are referred to exposed skin, it is important to remember the protection from burn that can be achieved with clothing. That protection, however, is not absolute. At temperatures below those required to ignite clothing, it is possible to transfer sufficient thermal energy across clothing to the skin to produce flash burns. The amount of heat energy conducted across clothing is a function of the energy absorbed by and the thermal conducting properties of the clothing. It will also be a function of whether the clothing is tight fitting or loose. Two uniform combinations have been specifically tested to determine the incident thermal exposure necessary to produce second-degree burns to skin under clothing. Table 4-VII summarizes the thermal burn criteria for skin under the U.S. Army summer uniform and the U.S. Army chemical protective overgarment. As can be seen by comparison with Table 4-VI, clothing significantly reduces the effective range to produce second-degree burns, thus affording significant protection against thermal flash burns. It should be noted that, because of the modifying effect of the uniforms, the exposures necessary to cause second-degree burns beneath the uniforms are yield independent.

Table 4-VII. Incident Exposure Necessary to Cause Second-Degree Burns Under Clothing\*

Clothing**	All yields - joules/cm <sup>2</sup>
U.S. Army summer uniform (fatigue uniform and undershirt)	62.7
U.S. Army chemical protective overgarment (battledress overgarment, fatigue uniform, and undershirt)	129.7

\* This is based on a 3mm separation between clothing and skin.  
 \*\* The U.S. fatigue uniform is made from 50% cotton and 50% nylon. The battledress overgarment shell is 50% nylon and 50% cotton, and the lining is 100% synthetic material impregnated with a charcoal slurry. Fluence required to produce second-degree burns under uniforms remains constant as yield varies.

## 411. Flame Burns.

Indirect or flame burns result from exposure to fires caused by the thermal effects in the environment, particularly from ignition of clothing. This could be the predominant cause of burns depending on the number of and characteristics of (e.g., man-made fibers) flammable objects in an environment. This is particularly true for the large yield weapons, which can cause conflagrations and fire storms over extensive areas. Complications arise in the treatment of skin burns which have been created, in part, by melting man-made fibers; therefore, it may be advisable for clothing made of natural fibers to be worn next to the skin. The probability of flame burns cannot be quantified with range as well as can flash burns. The variables of environmental flammability are too great to allow prediction of either incidence or severity. The burns themselves will be far less uniform in degree and will not be limited to exposed surfaces. For example, the respiratory system may be exposed to the effects of hot gases produced whenever extensive fires occur. Respiratory system burns are associated with severe morbidity and high mortality rates. Depending on the flammability of the material, blast winds may extinguish or fan the burning material.

## 412. Eye Injuries.

The effects of thermal/visual radiation on the eyes fall into two main categories, temporary flash blindness and permanent retinal scarring.

### a. *Flash Blindness.*

- (1) Flash blindness is caused by the initial brilliant flash of light produced by the nuclear detonation. More light energy is received on the retina than can be tolerated, but less than is required for irreversible injury. The retina is particularly susceptible to visible and short wavelength infrared light, since this part of the electromagnetic spectrum is focused by the lens with concentration of energy at the retinal surface. The result is bleaching of the visual pigments and temporary blindness.
- (2) During the daylight hours, flash blindness does not persist for more than about 2 minutes, but generally is of the order of seconds. At night, when the pupil is dilated for dark adaptation, flash blindness will affect personnel at greater ranges and will last for longer periods of time (Figure 4-I). Partial recovery, such that personnel could function in lighted areas, may be expected within 3 to 10 minutes. Impairment of dark adaptation and night vision will persist for longer periods, however, and may seriously reduce combat effectiveness. It may require 15-35 minutes for recovery of night adaptation, depending upon the amount of light energy absorbed.
- (3) Figure 4-I illustrates flashblindness and retinal burn safe separation distances for an observer on the ground, as a function of explosion yield, for burst heights of 3,000 meters at night and on a clear day. Safe separation distances are those distances beyond which persons on the ground would not receive incapacitating eye injuries.

b. *Retinal Scarring.* A retinal burn resulting in permanent damage from scarring is also caused by the concentration of direct thermal energy on the retina by the lens. It will

occur only when the fireball is actually in the individual's field of vision and would be a relatively uncommon injury. Retinal burns, however, may be sustained at considerable distances from the explosion (Figure 4-I). The apparent size of the fireball, a function of yield and range will determine the degree and extent of retinal scarring. The location of the scar will determine the degree of interference with vision, with a scar in the central visual field being potentially much more debilitating. Generally, a limited visual field defect, which will be barely noticeable, is all that is likely to occur.

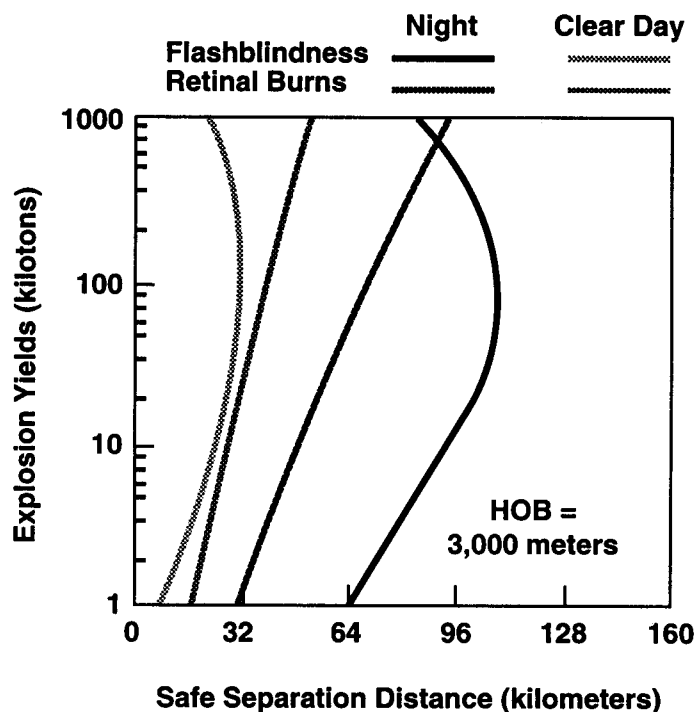


Figure 4-I. Flashblindness and Retinal Burn Safe Separation

## CHAPTER 5

## BIOPHYSICAL AND BIOLOGICAL EFFECTS OF IONIZING RADIATION

## SECTION I- GENERAL

**501. Introduction.**

- a. This chapter will cover basic biophysical and biological effects of ionizing radiation in order to form a foundation for understanding the clinical aspects of radiation injury discussed in Section IV of Chapter 6. This extended discussion of radiation does not imply that nuclear radiation will be the most important cause of casualties after a nuclear explosion. Blast and thermal injuries in many cases will far outnumber radiation injuries. However, radiation effects are considerably more complex and varied than are blast or thermal effects and are subject to considerable misunderstanding. As a result, a more detailed discussion is warranted. Since data from human experience are limited, much of the information in this chapter is based upon experimental information from animal studies.
- b. A wide range of biological changes may follow the irradiation of an animal, ranging from rapid death following high doses of penetrating whole-body radiation to an essentially normal life for a variable period of time until the development of delayed radiation effects, in a portion of the exposed population, following low dose exposures. The nature and severity of these changes will depend upon a great variety of biological and physical factors. There are significant variations in response to irradiation associated with differences in species, age, and other biological factors, as well as the physical factors of dose, dose rate, or nature of the radiation. However, the biological responses to radiation are not unique. They fall within the range of standard tissue responses seen following other types of injury and occur as a result of similar biochemical and/or cell kinetic disturbances. As a result, the wide range of effects which is possible can be organized into a predictable scheme, the details of which form the basic material of this chapter.

## SECTION II - BASIC BIOPHYSICAL ACTION OF IONIZING RADIATION

**502. Nuclear Radiation.**

A wide variety of ionizing radiation can interact with biological systems, but there are only four types of radiation associated with atmospheric and underground nuclear detonations of biological significance. In order of importance, they are gamma, neutron, beta, and alpha. The physical natures of these are discussed at length in Chapter 2. However, certain aspects of their mechanisms of interaction with living tissue are summarized here.

### 503. Gamma Radiation.

- a. Gamma radiation, emitted during the nuclear detonation or later in fallout, is highly energetic and is so penetrating that a significant part will pass through the human body without interaction. About 75% of the photons will interact with and lose energy to the atoms of the target tissue. This energy deposition may occur anywhere along a given photon's path, and therefore, anywhere in the body. If the gamma photon flux is high and the whole body is exposed, a fairly homogeneous deposition of energy will occur. This is in marked contrast to the highly localized energy deposition patterns of alpha and beta radiations.
- b. Because of its penetrating ability, the effects of gamma irradiation can be independent of the location of the source, (i.e., internal or external to the body). High-energy gamma emitters deposited within the body can result in total body irradiation just as effectively as external sources, if the quantities deposited are large enough and despite the fact that the emitters may not be distributed uniformly throughout the body.

### 504. Neutron Radiation.

#### a. *Neutron Interaction.*

- (1) Since neutrons are uncharged particles and can react only with the nuclei of target atoms, the probability of interaction of neutrons in the energy range characteristic of the fission spectrum detonation during their path through the human body is roughly comparable to that of low-energy gamma photons. Therefore, neutron radiation can result in whole-body irradiation. The energy deposition will not be uniform, and the side of the body which faces the detonation will absorb more energy than the opposite side. However, this difference, although of great theoretical interest, is not of operational importance. The major effect of this nonuniform deposition of energy will be to cause a wide variation in the typical radiation doses causing radiation sickness rather than significant variation in the overall clinical effects.
- (2) As noted above, neutrons, since they are uncharged neutral particles, do not interact with the orbital electrons of atoms as do other forms of radiation. Instead, they interact with atomic nuclei directly. Because of their mass and energy, neutrons can cause severe disruptions in atomic structure, typically causing a recoil "escape" of a target nucleus from its orbital electrons. This is much more common with the very light atoms, particularly hydrogen, since the mass of the photon making up the nucleus of common hydrogen is the major target atom in living tissue. When the nuclei of these latter are accelerated they are capable of causing dense ionization along their paths.
- (3) In biological material, elastic collisions of this type between neutrons and the nuclei of light-weight atoms predominate. Due to their short range, the accelerated nuclei produced by these collisions will expend their energy along short tracks of high excitation and ionization density. In tissue, about 70% to 85% of the entire fast neutron energy is transferred to recoil hydrogen

nuclei. The remainder of the neutron energy is dissipated in recoil nuclei of the other atoms noted above.

- (4) After the neutrons have lost most of their energy through these collisions, they will reach an equilibrium energy state in which they are referred to as thermal neutrons. Such relatively slow moving neutrons have a high probability of being captured by the nuclei of a wide variety of elements such as sodium. The resulting materials are radioactive and generally decay rapidly. The resulting tissue irradiation is not a significant factor in radiation injury since the total energy released by the decay of these radioactive materials is extremely small compared to the total energy absorbed from the neutrons by elastic collisions. However, the quantities can be measured and can be used to estimate neutron doses in limited numbers of casualties.

**b. Neutron Relative Biological Effectiveness.**

- (1) Relative biological effectiveness represents the effectiveness of a given radiation, compared to a reference radiation, (250 kilovolts (Kvp) x-rays), in producing the same level of response. Relative Biological Effectiveness (RBE) is defined as the ratio of the absorbed dose of a reference radiation to the absorbed dose of a test radiation to produce the same level of biological effect, other conditions being equal. (See Table 5-1.) When two radiations produce a biological effect that is not of the same extent and/or nature, the RBE cannot be specified.
- (2) Marked changes in behavior, vomiting, cardiovascular disorders, neurological symptoms, and other symptoms have been observed in monkeys irradiated at doses between 0.5 and 6.5 gray (Gy) by a fission neutron flux with neutron dose/gamma dose ratios varying from 1 to 12 and a dose rate close to those delivered by “conventional” nuclear weapons.

*Table 5-1. Relative Biological Effectiveness*

Radiation	RBE
X-rays	1
Gamma rays	1
Beta particles	1
Alpha particles (into the body)	10 to 20
Neutrons:	
For immediate radiation injury	1
For cataracts, leukemia and genetic changes	4 to 10

- (3) It was found that the neutron RBE (fission spectrum neutrons) for these disturbances was approximately between 0.5 and 1.2 in the range from 0.5 to 6.5 Gy. These RBE values must be confirmed by using a gamma radiation source with a dose rate comparable to that delivered by the reactors used and compared with those which would be obtained with neutrons from a fusion weapon. The above results lay particular stress upon the importance of intermediate dose and the biological effects of these as causes of incapacity can no longer be regarded as insignificant. In operational terms, neutron RBE varies with neutron energy, with neutron dose (the size of the neutron dose/gamma dose ratio), the dose rate and above all the dose gradient, particularly for determination of hematological LD<sub>50</sub>, but doubtless also for vomiting and early transient incapacitation (ETI). The RBE for ETI has been established as being equal to 1, because insufficient evidence has been collected to indicate otherwise. Relating dose to radiation effects in humans and other large mammals is further complicated by the fact that mixed-spectrum radiations change as they interact with body tissue. This change in quality of a mixed-spectrum field is significant since the biological damages produced by high-LET and low-LET radiations are not equivalent. High-LET radiations such as alpha particles or fast neutrons are generally regarded to have a greater relative biological effectiveness than low-LET radiations such as x-rays and gamma photons. The one exception to this generalization that seems to be significant in predicting the effects of ionizing radiation on combat personnel is that gamma photons have been found to be more effective in producing early transient incapacitation than either high-energy neutrons or fission spectrum neutrons.

### 505. Beta Radiation.

- a. High speed electrons in the form of beta radiation lose most of their energy after penetrating only a few millimeters of tissue. If the beta emitting material is on the surface of the skin, the resulting beta irradiation causes damage to the basal stratum of the skin. The lesion is similar to a superficial thermal burn. However, if the beta material is incorporated internally, the beta radiation can cause much more significant damage. The damage will be in spheres of tissue around each fragment or source of radioactive material. The total damage is a function of the number of sources and their distribution in the body. The distribution is determined by the chemical nature of the material.
- b. Table 5-II lists the critical ranges of radiation exposure in tissue for beta emitters of various energies. These ranges are considerably greater than those for alpha particles (Table 5-III). In addition to a difference in range when compared with alpha radiation, there is also a significant difference in the pattern of energy deposition. The density of energy deposited is much less for beta irradiation than for alpha, and as a result, the target cells may be damaged rather than killed outright. Damaged cells may be of greater significance to the total organism than killed cells, particularly if they go on to become malignant or otherwise malfunction. Killed



cells are replaced quickly in most tissues with any degree of reserve capacity and do not cause significant overall clinical effects unless the cells involved are highly critical or the fraction of cells killed in a given organ is large.

*Table 5-II. Tissue Dose Rate at Various Distances Around a 37 KBq (1μCi) Particle of Various Beta Emitting Materials (Range in Tissue 1-10 mm)*

Distance	Dose rate		
	<sup>14</sup> C	<sup>90</sup> SR - <sup>90</sup> Y	<sup>32</sup> P
10μm	2,000,000	766,400	380,000
100μm -0.1 mm	1,500	7,380	3,700
200μm - 0.2 mm	40	1,705	930
400μm - 0.4 mm	0.03	340	230
600μm -0.6 mm	0	130	100
1,000μm -1.0 mm	0	34	30
10,000μm -10.0 mm	0	0.02	0
Max. beta energy (MeV)	0.156	0.546-2.27	1.71

*Table 5-III. Tissue Dose Rate at Various Distances from a 37 KBq (1μCi) Alpha Emitter*

Distance (μm)	Dose rate at distance (cGy/hr)
10	1.7 x 10 <sup>8</sup>
20	5.2 x 10 <sup>7</sup>
30	0

### 506. Alpha Radiation

- a. The energy of these relatively heavy, positively charged particles is fully absorbed within the first 20 micrometers of an exposed tissue mass. If the source of the radiation is external, all of the alpha radiation is absorbed in the superficial layers of dead cells within the stratum corneum. If anything, even tissue paper, is interposed, the alpha particles will be absorbed, and not reach the skin. Because of this, alpha radiation is not an external hazard. If alpha emitting material is internally deposited, all the radiation energy will be absorbed in a very small volume of tissue immediately surrounding each particle. Alpha radiation has such limited penetrating ability that the maximum range for the highest energy alpha particle in tissue is less

- than 100 micrometers. Thus, while extremely high radiation doses may be deposited in the few cells immediately surrounding a source of alpha radiation, regions outside this small irradiated spherical volume are not affected. Table 5-III illustrates this for a 37 KBq (1.0  $\mu$ Ci) source of an alpha emitter of moderate energy.
- b. Beyond a radius of about 20 micrometers, the deposition of energy is very small. Due to the high radiation doses within this critical radius, the cells immediately adjacent to the source are killed. They would then be removed by phagocytosis or replaced by fibrosis. Relatively little damage to the intact organism results, unless these cells are themselves highly critical. Most tissues with a reasonable reserve can tolerate the loss of a few cells quite readily, particularly if the tissues have a normally high turnover rate. Therefore, although internal alpha radiation can be lethal to individual cells, the overall acute hazard is small. Internal deposition of alpha particles are of importance on a long term basis in terms of causing radiation injury which is of greater significance than from beta particles. However, injury from internal deposition of alpha particles is not of military importance.
  - c. However, many alpha emitting materials also emit gamma radiation, and this gamma radiation may cause significant tissue injury, even though the total alpha energy exceeds the total gamma energy and the ratio of gamma emissions per alpha is very small. This follows from the fact that the penetrating power of gamma radiation is many times greater than that for alpha radiation so that the total volume of tissue exposed to damaging radiation is many times greater.

### 507. Radiochemical Action.

- a. When radiation interacts with target atoms, energy is deposited, resulting in ionization or electron excitation as described in Chapter 2. This ionization or excitation must involve certain critical molecules or structures in a cell in order that the damage caused by radiation may follow the consistent patterns it does. It has been theorized that this localization of absorbed energy in critical molecules could be either a direct or an indirect action, i.e., the energy deposited by the radiation may involve particular sensitive chemical bonds directly, or it may be deposited elsewhere first and transferred to the sensitive bonds by means of an appropriate energy transfer system. The former mechanism implies that the radiation quite precisely hits particular target atoms, whereas the latter implies that there is a method for preferentially directing randomly deposited energy to sensitive sites.
- b. The exact radiochemical mechanism involved in mammalian systems subjected to whole-body doses of penetrating radiation is not fully understood. However, the most reasonable hypothesis at the present time is that water, both intracellular and extracellular, is the primary site of radiation energy deposition and that the energy deposited in the water would be transferred to and affect sensitive molecules indirectly.

## SECTION III - CELLULAR EFFECTS OF IONIZING RADIATION

## 508. General.

Observed cellular effects of radiation, whether due to direct or indirect damage, are basically similar for different kinds and doses of ionizing radiation.

- a. *Cell Death.* One of the simplest effects to observe is cell death, the course of which can be described by various terms.
  - (1) *Pyknosis.* The nucleus becomes contracted, spheroidal, and filled with condensed chromatin.
  - (2) *Karyolysis.* The nucleus swells and loses its chromatin.
  - (3) *Protoplasmic Coagulation.* Irreversible gelatin formation occurs in both the cytoplasm and nucleus.
  - (4) *Karyorrhexis.* The nucleus becomes fragmented and scattered throughout the cell.
  - (5) *Cytolysis.* Cells swell until they burst and then slowly disappear.
- b. *Changes in Cell Function.* Nonlethal changes in cellular function can occur as a result of lower radiation doses. These include delays in certain phases of the mitotic cycle, disrupted cell growth, permeability changes, and changes in motility.
  - (1) *Mitotic Cycle.* Mitosis may be delayed or inhibited following radiation exposure. Dose dependent inhibition of mitosis is particularly common in actively proliferating cell systems. This inhibition occurs approximately 40 minutes before prophase in the mitotic cycle, at a time when the chromosomes are discrete, but prior to the breakdown of the nuclear membrane. Subsequent irradiation after this radiation transition point does not delay mitosis. Delays in mitosis can cause profound alterations in cell kinetic patterns resulting in depletions of all populations. This is the basic kinetic patterns resulting in depletions of all populations. This is the basic mechanism underlying the later clinical changes seen in the hematopoietic and gastrointestinal syndromes of whole-body irradiation.
  - (2) *Disruptions in Cell Growth.* Cell growth may also be retarded, usually after a latent period. This may be due to progressive formation of inhibitory metabolic products and/or alterations in the cell microenvironment.
  - (3) *Permeability Changes.* Irradiated cells may show both increased and decreased permeability. Radiation changes within the lipid bilayers of the membrane may alter ionic pumps. This may be due to changes in the viscosity of intracellular fluids associated with disruptions in the ratio of bound to unbound water. Such changes would result in an impairment of the ability of the cell to maintain metabolic equilibrium and could be very damaging even if the shift in equilibrium were quite small.
  - (4) *Changes in Cell Motility.* The motility of a cell may be decreased following irradiation. However, the presence of normal motility does not imply the absence of radiation injury. Irradiated spermatozoa, for example, may retain their motility and be capable of fertilization while carrying radiation-induced genetic changes which may alter subsequent embryogenesis.

## 509. Relative Cellular Radiosensitivity.

In general, actively proliferating cells are most sensitive to radiation. On the other hand, the mitotic activity of all cells decreases with maturation. Thus, cellular radiosensitivity tends to vary inversely with the degree of differentiation. Cells may be classified functionally and in decreasing order of sensitivity into four categories: vegetative cells, differentiating cells, totally differentiated cells, and fixed non-replicating cells.

- a. *Vegetative Cells.* These cells, comprising differentiated functional cells of a large variety of tissues, are generally the most radiosensitive. Examples include:
  - (1) Free stem cells of hematopoietic tissue (hemocytoblasts, primitive lymphoblasts, primitive erythroblasts, and primitive myeloblasts).
  - (2) Dividing cells deep in the intestinal crypts.
  - (3) Primitive spermatogonia in the epitheliums of the seminiferous tubules.
  - (4) Granulosa cells of developing and mature ovarian follicles.
  - (5) Basal germinal cells of the epidermis.
  - (6) Germinal cells of the gastric glands.
  - (7) Large and medium sized lymphocytes.
  - (8) Small lymphocytes, which are not included normally in this class of cells, but which are also highly radiosensitive.
  - (9) Mesenchymal cells.
- b. *Differentiating Cells.* These cells are somewhat less sensitive to radiation. They are relatively short-lived and include the first generation produced by division of the vegetative mitotic cells. They usually continue to divide a limited number of times and differentiate to some degree between divisions. As differentiation occurs, radiosensitivity decreases. The best examples of this type of cell are the dividing and differentiating cells of the granulocytic and erythrocytic series in the bone marrow. This type also includes the more differentiated spermatogonia and spermatocytes in the seminiferous tubules and the oocytes.
- c. *Totally Differentiated Cells.* These cells are relatively radioresistant. They normally have relatively long lifespans and do not undergo regular or periodic division in the adult stage, except under abnormal conditions such as following damage to or destruction of a large number of their own kind. This class includes hepatocytes, cells of interstitial gland tissue of the gonads, smooth muscle cells, and vascular endothelial cells.
- d. *Fixed Nonreplicating Cells.* These cells are most radioresistant. They do not normally divide, and some types, such as neurons, do not divide under any circumstances. They are highly differentiated morphologically and highly specialized in function. Cells in this group have widely varied life-spans and show progressive aging. This group includes the long-lived neurons, striated muscle cells, short-lived polymorphonuclear granulocytes and erythrocytes, spermatids and spermatozoa, and the superficial epithelial cells of the alimentary tract.

**510. Relative Organ Radiosensitivity.**

The relative sensitivity of an organ to direct radiation injury depends upon its component tissue sensitivities. Table 5-IV lists various organs in decreasing order of radiosensitivity on the basis of a relatively direct radiation effect, parenchymal hypoplasia.

*Table 5-IV. Relative Radiosensitivity of Various Organs Based on Parenchymal Hypoplasia*

Organs	Relative radiosensitivity	Chief mechanism of parenchymal hypoplasia
Lymphoid organs; bone marrow; testes & ovaries; small intestines	High*	Destruction of parenchymal cells, especially the vegetative or differentiating cells
Skin; cornea & lens of eyes; gastrointestinal organs: cavity, esophagus, stomach, rectum	Fairly high	Destruction of vegetable and differentiating cells of the stratified epithelium
Growing cartilage; the vasculature; growing bones	Medium	Destruction of proliferating chondroblasts or osteoblasts; damage to the endothelium; destruction of connective tissue cells & chondroblasts or osteoblasts
Mature cartilage or bone; lungs; kidneys; liver; pancreas; adrenal gland; pituitary gland	Fairly low	Hypoplasia secondary damage to the fine vasculature and connective tissue elements
Muscle; brain; spinal cord	Low	Hypoplasia secondary damage to the fine vasculature and connective tissue elements, with little contribution by the direct effects on parenchymal tissues

\*Embryonic tissue is also highly radiosensitive.

**511. Radiation-Induced Chromosome Damage.**

- a. Cell nuclei contain chromosomes which in turn contain the genes controlling cellular somatic and reproductive activity. These chromosomes are composed of deoxyribonucleic acid (DNA), the macromolecule containing the genetic information. This is a large, tightly coiled, double-stranded molecule and is sensitive to radiation damage. Radiation effects range from complete breaks of the

nucleotide chains of DNA, to point mutations which are essentially radiation-induced chemical changes in the nucleotides which may not affect the integrity of the basic structure. Intermediate effects, such as abnormal bonding between adjacent molecules and alterations in viscosity, have also been observed.

- b. After irradiation, chromosomes may appear to be “sticky” with formation of temporary or permanent interchromosomal bridges preventing normal chromosome separation during mitosis and transcription of genetic information. Unequal division of nuclear chromosome material between daughter cells with production of nonviable abnormal nuclei may result.

## 512. Genetic Effects.

Laboratory studies in animals indicate increased mutation rates with small doses of radiation. As radiation dose increases, mutation induction also increases. Mutations per unit dose decrease at low dose rates. However, viable mutations are still extremely rare. Most of the mutations are lethal and thus self-limiting. It must be kept in mind that radiation doses increase natural mutation rates and that the mutations produced, and not visibly detected, are permanent in regard to future generations.

## 513. Cell Kinetic Effects.

- a. Each of the numerous cell renewal systems making up an animal's total cellular mass is normally in an equilibrium state between cell formation, proliferation, maturation, and death. Some systems, such as the adult central nervous system in higher animals, are stabilized at the end point of maturation, and the functional cells of such a system are not replaced if lost or destroyed. Other organ systems, such as the liver, which do not normally replace cells at a rapid rate, have the potential to regenerate large numbers of cells if needed. Other organ systems, such as the skin, the reproductive system, the gastrointestinal tract, and the hematopoietic system in the bone marrow, maintain a continuous high cell turnover rate. Bone marrow also has a large reserve capacity in the adult. A large fraction of it is normally nonfunctioning but has the potential to be functional if required. Failure of a particular organ system may or may not lead to death of the animal, depending on the importance of that system's functions, i.e., failure of gonadal function would not be lethal, whereas failure of bone-marrow function would be.
- b. Regardless of the biophysical processes involved, one of the major biological effects of whole-body radiation, in the dose ranges causing the syndromes of bone-marrow depression and gastrointestinal damage, is a profound disturbance in the cell kinetics of these systems. Both the hematopoietic and the gastrointestinal system have fairly rapid cellular replacement rates and normally contain cell populations in all stages of maturation and differentiation from primitive stem cells to mature functional cells.
- c. The stem cells of the various cell lines of these systems are almost all relatively sensitive to radiation whereas the mature functional cells are relatively resistant. As a result, following radiation, injured stem cells are not likely to mature. When the mature cells

die or are otherwise lost they will not be replaced and the overall population of cells in the system will be decreased. If the radiation injury is repairable, recovery of the ability of a stem cell population to mature will result in a gradual return of a mature, functional population. If the damage is irreversibly severe, there will be no recovery.

#### **514. Bone-Marrow Kinetics.**

The bone marrow contains three cell renewal systems: the erythropoietic (red cell), the myelopoietic (white cell), and the thrombopoietic (platelet). The time cycles and cellular distribution patterns and postirradiation responses of these three systems are quite different.

- a. Studies suggest that a pluripotential stem cell gives rise to these three main cell lines in the bone marrow. Beyond this stem cell, each cell renewal system consists of a stem cell compartment for the production of erythrocytes, leukocytes (lymphocytes, granulocytes, monocytes, etc.), or platelets, a dividing and differentiating compartment, a maturing (nondividing) compartment, and a compartment containing mature functional cells.
- b. Research studies suggest that each of these cell renewal systems operates under the influence of regulating factors, primarily at the stem cell level, through a negative feedback system initiated in large measure by the level of mature circulating cells in the peripheral blood. Normally, a steady-state condition exists between new cell production by the bone marrow and the numbers of functional cells. Morphological and functional studies have shown that each cell line, i.e., erythrocyte, leukocyte, and platelet, has its own unique renewal kinetics. The time-related responses evident in each of these cell renewal systems after irradiation are integrally related to the normal cytokinetics of each cell system.

#### **515. Erythropoietic.**

- a. The function of this cell renewal system is to produce mature erythrocytes for the circulation. The transit time from the stem cell stage in the bone marrow to the mature red cell ranges from 4 to 7 days, after which the life-span of the red cell is approximately 120 days. The immature forms, i.e., erythroblast and proerythroblast, undergo mitosis as they progress through the dividing and differentiating compartment. Because of their rapid proliferating characteristics they are markedly sensitive to cell killing by ionizing radiation. Cell stages within the maturing (nondividing) and functional compartments, i.e., normoblast, reticulocyte, and red cell, are not significantly affected by midlethal to lethal range doses. The death of stem cells and of those within the next compartment is responsible for the depression of erythropoietic marrow and, if sufficiently severe, is responsible together with hemorrhage for subsequent radiation-induced anemia. Because of the relatively slow turnover rate, e.g., approximately 1 percent loss of red cell mass per day, in comparison with leukocytes and platelets, evidence of anemia is manifested subsequent to the depression of the other cell lines, provided that significant hemorrhage has not occurred.
- b. The erythropoietic system has a marked propensity for regeneration following

irradiation from which survival is possible. After sublethal exposures, marrow erythropoiesis normally recovers slightly earlier than granulopoiesis and thrombopoiesis and occasionally overshoots the base-line level before levels at or near normal are reached. Reticulocytosis, occasionally evident in peripheral blood smears during the early intense regenerative phase occurring after maximum depression, often closely follows the temporal pattern of marrow erythropoietic recovery. Although anemia may be evident in the later stages of the bone-marrow syndrome, it should not be considered a survival-limiting sequela.

### **516. Myelopoietic.**

- a. The function of the myelopoietic marrow cell renewal system is mainly to produce mature granulocytes, i.e., neutrophils, eosinophils, and basophils, for the circulating blood. Of these, the neutrophils, because of their role in combatting infection, are the most important cell type in this cell line. The stem cells and those developing stages within the dividing and differentiating compartment are the most radiosensitive. These include the myeloblast, progranulocyte and myelocyte stages. As with the erythropoietic system, cell stages within the maturing (nondividing) compartment and the mature functional compartment, i.e., granulocytes, are not significantly affected by radiation doses within the midlethal range. Three to seven days are normally required for the mature circulating neutrophil granulocyte to form from its stem cell precursor stage in the bone marrow.
- b. Mature functional granulocytes are available upon demand from venous, splenic and bone-marrow pools. Following an initial increase in circulating granulocytes (of unknown etiology), these pools are normally depleted before granulocytopenia is evident soon after radiation-induced bone-marrow injury. Because of the rapid turnover of the granulocyte cell renewal system due to the short life-span of its cells (approximately 8 days), evidence of radiation damage to marrow myelopoiesis occurs in the peripheral blood within 2 to 4 days after whole-body irradiation. The brief latent period between the time of irradiation and the beginning depletion of circulating granulocytes is related to the transit time of the nonradiosensitive cells within the nondividing, maturing marrow compartment, i.e., metamyelocyte and band forms, during their development into mature circulating granulocytes. Maturation depletion of these stages in the absence of feed-in of the earlier radiosensitive stages damaged by radiation accounts for the granulocytopenia.
- c. Recovery of myelopoiesis lags slightly behind erythropoiesis and is accompanied by rapid increases in numbers of differentiating and dividing forms in the marrow. Prompt recovery is occasionally manifested and is indicated by increased numbers of band cells in the peripheral blood.

### **517. Thrombopoietic.**

- a. The thrombopoietic cell renewal system is responsible for the production of platelets (thrombocytes) for the peripheral circulating blood. Platelets along with granulocytes constitute two of the most important cell types in the circulation, the



levels of which during the critical phase after midlethal doses will markedly influence the survival or nonsurvival of irradiated personnel. Platelets are produced by megakaryocytes in the bone marrow. Both platelets and mature megakaryocytes are relatively radioresistant; however, the stem cells and immature stages are very radiosensitive. During their developmental progression through the bone marrow, megakaryocytic precursor cells undergo nuclear division without cell division. The transit time through the megakaryocyte proliferating compartment in humans ranges from 4 to 10 days. Platelets have a life-span of 8 to 9 days.

- b. Although platelet production by megakaryocytes may be reduced by a high dose of ionizing radiation, the primary effect is on stem cells and immature megakaryocyte stages in the bone marrow. As with the erythropoietic and myelopoietic systems, the time of beginning depression of circulating platelets is influenced by the normal turnover kinetics of cells within the maturing and functional compartments. Early platelet depression, reaching thrombocytopenic levels by 3 to 4 weeks after midlethal range doses, occurs from killing of stem cells and immature megakaryocyte stages and from maturation depletion of maturing and functional megakaryocytes.
- c. Regeneration of thrombocytopoiesis after sublethal irradiation normally lags behind both erythropoiesis and myelopoiesis. Supranormal platelet numbers which overshoot the preirradiation level have occurred during the intense regenerative phase in human nuclear accident victims. The mechanism of the prompt rapid recovery of platelet numbers after acute sublethal irradiation may be explained by the response of the surviving and regenerating stem cell pool to a human feedback stimulus from the acute thrombocytopenic condition. Accelerated differentiation and maturation of immature megakaryocytes as well as marked increases in size of megakaryocytes contribute to the intense platelet production and eventual restoration of steady-state levels. Blood coagulation defects with concomitant hemorrhage constitute important clinical sequelae during the thrombocytopenic phase of bone-marrow and gastrointestinal syndromes.

### **518. Gastrointestinal Kinetics.**

In view of the vulnerability of the small intestine to radiation damage and the important role it plays in the gastrointestinal syndrome, the cell renewal kinetics of the villi of this segment are important.

- a. The renewal system is in the crypt and villus where epithelial cell formation, migration and loss occur. The four cell renewal compartments are: stem cell and proliferating cell compartment, maturation compartment, functional compartment, and the extrusion zone. Stem cells and proliferating cells move from crypts into a maturing only compartment at the neck of the crypts and base of the villi. Functionally mature epithelial cells then migrate up the villus wall and are extruded at the villus tip. The overall transit time from stem cell to extrusion on the villus for humans is estimated as being 7 to 8 days. Shorter times for epithelial cell renewal systems have been reported in experimental animals.
- b. Because of the high turnover rate occurring within the stem cell and proliferating cell compartment of the crypt, marked damage occurs in this region by whole-body

radiation doses above the midlethal range. Destruction as well as mitotic inhibition occurs within the highly radiosensitive crypt and proliferating cell compartments within hours after high doses. Maturing and functional epithelial cells continue to migrate up the villus wall and are extruded albeit the process is slowed. Shrinkage of villi and morphological changes in mucosal cells, i.e., columnar to cuboidal to squamoid, occur as new cell production is diminished within the crypts. Continued extrusion of epithelial cells in the absence of cell production can result in denudation of the intestinal mucosa. Concomitant injury to the microvasculature of the mucosa and submucosa in combination with epithelial cell denudation results in hemorrhage and marked fluid and electrolyte loss contributing to shock. These events normally occur within 1 to 2 weeks after irradiation. A second mechanism of injury has recently been detected at the lower range of the gastrointestinal syndrome, or before major denudation occurs at higher doses of radiation. This response is a functional increase in fluid and electrolyte secretion on the epithelial cells without visible cell damage. This second mechanism may have important implications for fluid replacement therapy. Other secondary complications which contribute significantly to the gastrointestinal syndrome will be described elsewhere.

#### SECTION IV - SYSTEMIC EFFECTS OF WHOLE-BODY IRRADIATION

##### 519. General.

Whole-body irradiation is the most important type of radiation exposure since it is the most damaging and is discussed in the greatest detail in this section. However, partial body and specific organ irradiation can occur, particularly from internal deposition and retention of radioactive fission products found in fallout. Basic biophysical principles of internal irradiation are also discussed in a later section of this chapter. Severe radiation sickness is seen following large dose of external whole-body irradiation. Variable lesser degrees of radiation sickness may occur following partial body irradiation. The mechanisms underlying the various syndromes of severe radiation sickness are emphasized in this section.

##### 520. Median Lethal Dose ( $LD_{50}$ ).

###### a. *Lethality.*

- (1) When comparing the effects of various types or circumstances, that dose which is lethal to 50% of a given population is a very useful parameter. The term is usually defined for a specific time, being limited, generally, to studies of acute lethality. The common time periods used are 30 days or less for most small laboratory animals and to 60 days for large animals and humans. On occasion, when a specific type of death is being studied, the time period used will be shorter. The specified period of time is indicated by a second number in the subscript;  $LD_{50/30}$  and  $LD_{50/5}$  indicate 50% mortality within 30 days and 5 days, respectively. The  $LD_{50}$  is a median; the easiest method of approximating it is by plotting experimental data on an appropriate graph and

- then estimating it by inspection. It should be understood that the  $LD_{50/60}$  assumes that the individuals did not receive other injuries or medical treatment.
- (2) Figure 5-I is a graphic representation of a typical mortality response to radiation. The curve drawn through the data points is sigmoid, indicating that the mortality response to increasing dose approximates a normal distribution. A sigmoid curve is difficult to plot, particularly when the number of data points is limited, and a preferred method which allows the plotting of experimental data along a straight line is used in most mortality studies. Figure 5-II shows the same experimental data plotted on a specially constructed graph, termed a probit graph. This distortion is deliberate and is based upon the function of a normal distribution, so that data from a normal distribution can be plotted on such a graph, which seems to fit the data. The  $LD_{50}$  can then be estimated by inspection. This method is simple and used extensively. However, it should only be used when it has been demonstrated that the dose response phenomenon being studied does indeed follow or at least reasonably approximates a normal distribution. There is controversy about what the  $LD_{50/60}$  for humans is. A full discussion of this issue is beyond the scope of this overview.
- (3) Medically, other figures of interest are the dose that will kill virtually no one, ( $LD_5$ ), and the dose that will kill virtually every one ( $LD_{95}$ ). Approximations of those doses are within the ranges 200-300 cGy (free in air) and 600-700 cGy (free in air), respectively.

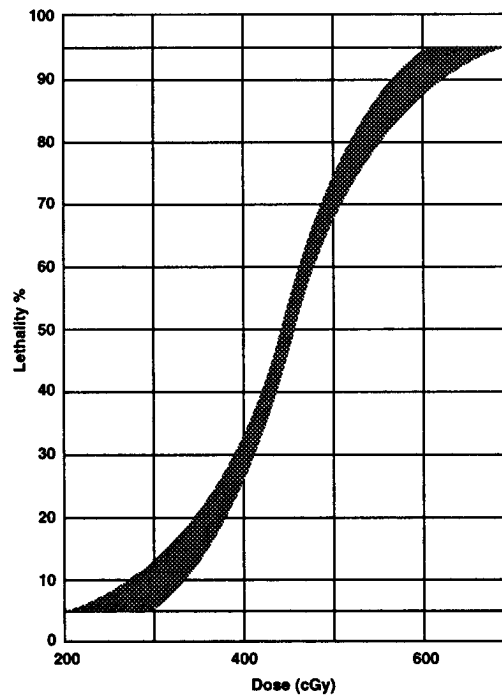


Figure 5-I. Typical Lethality as a Function of Dose

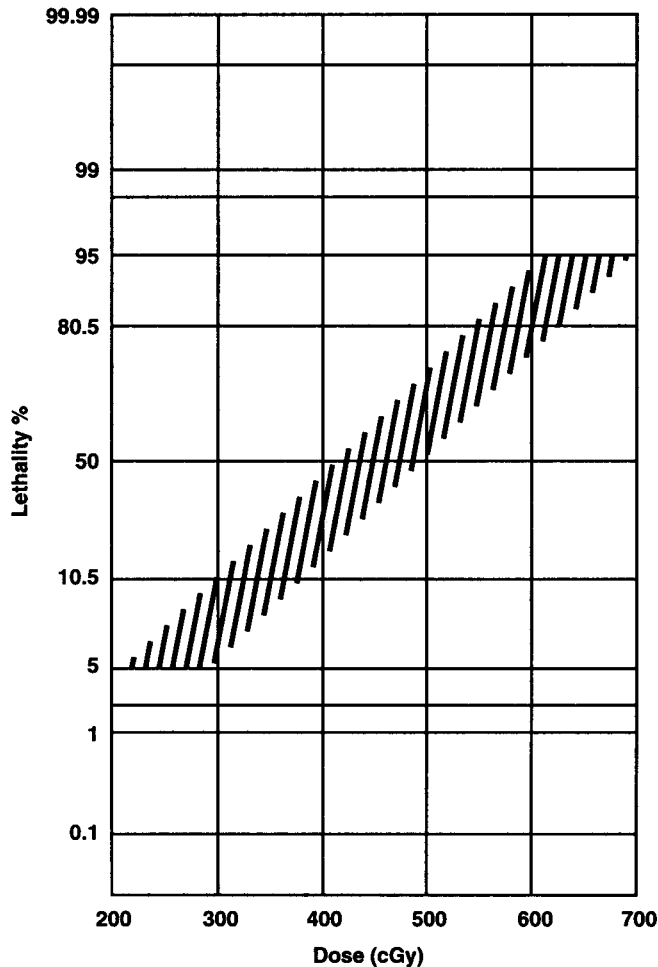


Figure 5-II. Lethality Response as a Function of Dose Obtained by Probit Analysis

**b. Radiation-Induced Early Incapacitation.**

(1) The focus of animal studies has been the incapacitation of the subhuman primate, since the incapacitation response has military relevance and the response of primates seems most like a human's response after acute whole-body irradiation. For high radiation doses (in excess of 1000 cGy), early transient incapacitation (ETI) occurs on average within 5 to 10 minutes after acute whole-body irradiation. With lowering the dose the median time of ETI occurrence increases up to 12 to 15 minutes. Typical duration of ETI is of the order of 15 minutes. Performance decrement in the monkey has been evaluated for numerous behavioral tasks after whole-body and partial-body irradiation for various radiation qualities and dose rates. Several generalizations have emerged from these studies.

- (a) Early transient incapacitation is qualitatively very similar for many behavioral tasks.
  - (b) The frequency of incapacitation within a population increases as a function of radiation dose.
  - (c) Incapacitation can be elicited by either trunk-only or head-only irradiation.
  - (d) Neutrons are less effective in producing early transient incapacitation than are gamma photons. The relative biological effectiveness for incapacitation of neutrons to gammas has been estimated between 0.23 and 0.62.
  - (e) The frequency of incapacitation produced by a given radiation dose is proportional to the demands or stress of the task being performed. These findings and the data they represent are the basis for the current combat casualty criteria. The present criteria are based on the incapacitating dose levels for both physically demanding tasks and undemanding tasks. They do not include combat ineffectiveness due to partially degraded performance that may result from slower reaction to the task, task stress, or prodromal effects of the acute radiation sickness.
- (2) For yields of 5-10 Kt (or less), initial nuclear radiation is the dominant casualty producer on the battlefield. Military personnel receiving an acute incapacitation dose (30 Gy) will become performance degraded almost immediately and combat ineffective within several hours. However, they will not die until 5-6 days after exposure if they do not receive any other injuries which make them more susceptible to the radiation dose. Soldiers receiving less than a total of 150 cGy will remain combat effective. Between those two extremes, military personnel receiving doses greater than 150 cGy will become degraded; some will eventually die. A dose of 530-830 cGy is considered lethal but not immediately incapacitating. Personnel exposed to this amount of radiation will become performance degraded within 2-3 hours, depending on how physically demanding the tasks they must perform are, and will remain in this degraded state at least 2 days. However, at that point they will experience a recovery period and be effective at performing nondemanding tasks for about 6 days, after which they will relapse into a degraded state of performance and remain so for about 4 weeks. At this time they will begin exhibiting radiation symptoms of sufficient severity to render them totally ineffective. Death follows at approximately 6 weeks after exposure. Experiments conducted with animal models have shown that exposure to high doses of ionizing radiation (of the order of 25 Gy) results in an immediate precipitous decline in cerebral blood flow (CBF) which is followed by a partial recovery at 20-30 minutes, and subsequent slower secondary decrease in CBF thereafter accompanied by parallel changes in systemic blood pressure. These data indicate that radiation adversely affects the ability of the brain to regulate its blood supply. The implication of this indication extends into the realm of behavioral studies of early transient incapacitation and performance decrement (ETI-PD). The activity of certain

brain enzymes involved in neurotransmitter metabolism is also considerably affected during ETI.

- (3) Experimental results from animal studies indicate that, in general, partial body shielding reduces the behavioral effects of radiation. Head shielding is more effective in preserving the behavioral performance after exposure than is trunk shielding. Head shielding not only reduces the incidence of incapacitation but reduces the incidence of convulsions that normally accompanies early incapacitation. In all experimental causes studied to date, head shielding is most effective for doses in excess of 25 Gy.

## 521. Reproductive Cell Kinetics and Sterility.

- a. Despite the high degree of radiosensitivity of some stages of germ cell development, the testes and ovaries are only transiently affected by single sublethal doses of whole-body irradiation and generally go on to recover normal function. In male test animals, low doses of whole-body irradiation cause abrupt decreases in sperm counts. The degree of decrease is dose dependent, but a transient azoospermia can appear at sublethal radiation doses. The resulting sterility may last several months to several years, but recovery of natural fertility does occur. The recovery depends upon the regeneration of those elements of the stem cell population which were in a relatively resistant part of the germ cell cycle. Other data suggest that under some conditions new spermatogonia may be formed by transformation from more radioresistant fixed stem cells.
- b. When chromosome aberrations are produced in somatic cells, the injury is restricted to the specific tissue or cell system. However, when aberrations occur in germ cells, the effects may be reflected in subsequent generations. Most frequently, the stem cells of the germ cell line do not develop into mature sperm cells or ova, and no abnormalities are transmitted. If the abnormalities are not severe enough to prevent fertilization, the developing embryos will not be viable in most instances. Only when the chromosome damage is very slight and there is no actual loss of genetic material will the offspring be viable and abnormalities be transferable to succeeding generations. These point mutations become important at low radiation dose levels. In any population of cells, spontaneous point mutations occur naturally. Radiation increases the rate of these mutations and thus increases the abnormal genetic burden of future generations.

## 522. Recovery.

### a. *Recovery Processes.*

- (1) A variety of recovery processes may reduce radiation damage to a varying extent. For example, when a chromosome is broken, the broken ends tend to rejoin thus reconstituting the chromosome, but occasionally the broken ends seal over before rejoining thus leaving permanent chromosome damage. If two (or more) chromosomes are broken within the same cell, rejoining of inappropriate broken ends can occur and so may lead to permanent

chromosomal change of a different kind. Repair of the broken ends of chromosomes, like all other repair processes following radiation damage, is not specific in respect of radiation damage. Repair is a biological process specific to a particular kind of damage which comes into play whatever the agent which causes that damage. These particular examples and others relating to DNA and its repair or to increased permeability of cell membranes, etc., are important in practice only for very large exposures.

- (2) Three specific recovery processes are directly relevant to the medical aspects of defense operations. The first is an intracellular recovery within individual cells which have been sublethally irradiated. The second is a specific recovery of a specific tissue in which killed or damaged cells are replaced by division of surviving and minimally damaged or undamaged cells within that tissue, a process often called repopulation. Between them, these two processes may allow a complete return of function to normal. When the local dose is large enough, repair may be possible but incomplete. Repair of a specific tissue may be carried out without complete replacement of all the cells of the tissue. Healing may involve tissue atrophy and/or fibrosis and the irradiated tissue may be permanently scarred. The third, a combination of the first two types of recovery, can be very approximately quantified for lethality in humans by the use of the operational equivalent dose formula in cases where the irradiation period is protracted over several hours or longer as might happen in fallout conditions.

b. *Intracellular Recovery.* Individual irradiated cells have the ability to repair themselves as long as the amount of intracellular damage does not exceed a threshold value. The basic reason why sublethally irradiated cells survive and then recover is that a certain minimum amount of radiation energy must be deposited within a cell in order to kill it. Even when a mass of cells is uniformly exposed to low LET radiation, the amount of radiation energy deposited in individual cells is not the same for each cell but varies widely from cell to cell. As the dose increases, the proportion of cells increases in which a just lethal or more than lethal amount of energy is deposited. But all the other irradiated cells, those in which either no radiation energy or a sublethal amount is deposited, restore themselves to normal if given sufficient time to do so. Although controversial, it is generally believed that this mechanism for recovery is more effective in cells not undergoing active cell division, e.g., quiescent stem cells, than in cells undergoing active cell division, e.g., the basal cells of the intestinal crypts and the ordinary blast cells of the bone marrow. In quiescent cells, full recovery from sublethal radiation damage takes only a few hours. This can be demonstrated by dividing a dose into 2 fractions separated by a few hours when the damage observed will be less than when the whole dose is given all at once. This so-called Elkind repair continues during a protracted exposure to radiation, such as to fallout. It does not require a radiation-free interval.

c. *Repopulation.*

- (1) Repopulation brought about by stem cell proliferation is a particularly important recovery mechanism in both the bone marrow and the gastrointestinal tract whenever the radiation exposure has been large enough

to reduce cell numbers. Stem cells divide normally in both these tissues, because stem cell turnover is required to compensate for the normal continuously occurring removal of differentiated cells. Stem cell division can be accelerated by large doses of radiation. Large doses of radiation cause enough damage to stimulate this repopulation, just as any other severe insult would do. The effects of small doses are not recognized soon enough for accelerated proliferation to take place.

- (2) In bone marrow, large microphage cells produce factors that either stimulate or shut down the stem cells that are the progenitors of the erythropoietic, granulopoietic, or thrombopoietic series of blood cells. The “factor producing” cells influence one another and depress the production of one factor while the opposite is being produced. Stem cell responses continue until the factor is changed. Some stem cells have the ability to cycle at faster rates than others but with lower efficiency, producing fewer mature cells eventually than the slower cycling cells. If the duration of exposure is sufficiently prolonged and the continued exposures are sufficiently large, then the repopulation process may become less efficient. However, it may take several months before the repopulation process becomes significantly impaired and so it is not likely to be relevant in a short duration nuclear warfare scenario.

d. *Problems with Application of An Equivalent Dose Formula.* It has long been realized that it is desirable to quantify recovery from ionizing radiation damage, especially when received more or less continuously over a period of time as would be expected when operating in fallout conditions. For operational reasons, the quantification needs to be relatively simple to use and should not require a computation with parameters that could not be established in a nuclear warfare scenario. Consequently, several equivalent dose formulas have been proposed which estimate the lethal dose from accumulated exposure. As such, these formulas can be used as guides to predict the levels of external exposure that could be tolerated from fallout fields. On the battlefield, however, they are of very limited use and could lead to serious overestimates of combat capability because they do not account for the effects of neutron exposures and predict only lethality, not radiation sickness, which could severely impair the effectiveness of combat personnel. Current equivalent dose formulas are applicable to a very small portion of a battlefield population, because they are valid only for external gamma doses received at low dose rates. Therefore, they cannot be used to predict the response of anyone exposed to neutrons. This limitation renders the formulas unusable for any military personnel irradiated at the time of a nuclear detonation since neutron dose is known to be more lethal than a comparable dose of gamma radiation alone. Present formulas potentially would be applicable only to forces being introduced into a fallout field after the cessation of nuclear detonations. Their practical use on the battlefield is further reduced by NATO and enemy nuclear targeting doctrine which call for detonations at altitudes that preclude the generation of fallout and by the difficulty in predicting arrival of fallout fields. Given the small range of application to the nuclear battlefield and the possible errors they might cause, current equivalent dose formulas are inappropriate for operational decision making on the nuclear battlefield.



## SECTION V - DELAYED EFFECTS

### 523. General.

Late or delayed effects of radiation occur following a wide range of doses and dose rates. Delayed effects may appear months to years after irradiation and include a wide variety of effects involving almost all tissues or organs. Some of the possible delayed consequences of radiation injury are life shortening, carcinogenesis, cataract formation, chronic radiodermatitis, decreased fertility, and genetic mutations.

### 524. Carcinogenesis.

- a. Irradiation of almost any part of the body increases the probability of cancer. The type formed depends on such factors as area irradiated, radiation dose, age, and species. Irradiation may either increase the absolute incidence of cancer or accelerate the time or onset of cancer appearance, or both. There is a latent period between the exposure and the clinical appearance of the cancer. In the case of the various radiation-induced cancers seen in mankind, the latency period may be several years. Latency as well as the dose required to induce cancers varies with the cancer site and with the species studied. Latent periods for induction of skin cancers in people have ranged from 12 to 56 years after x irradiation therapeutic exposures with estimated doses of several thousand roentgens. Fifteen years is reported as a latent period for bone tumors from radium. This latency related to bone tumors is very dependent upon the dose and type of radiation emitted by the radionuclide.
- b. A leukemogenic effect was expected and found among Hiroshima and Nagasaki survivors. Peak incidence occurred 6 years after exposure and was less marked for chronic granulocytic leukemia than acute leukemia. The incidence was inversely related to distance from the hypocenter. British persons receiving radiotherapy for spondylitis showed a dose response relationship for leukemia, with peak incidence occurring 5 years after the first exposure. Studies have demonstrated that ionizing radiation can induce more than one kind of leukemia in people, but not chronic lymphocytic leukemia.
- c. Predisposing factors for tumor development include heredity, age, hormones, and prior exposure to physical trauma, chemical agents and ionizing radiation. The actual processes by which cancer is induced are not known. Somatic mutations, virus infections, and precancerous abnormalities in tissue organization and vascular supply have all been postulated.

### 525. Cataract Formation.

A late effect of eye irradiation is cataract formation. It may begin anywhere from 6 months to several years after exposure. While all types of ionizing radiation may induce cataract formation, neutron irradiation is especially effective in its formation, even at relatively low doses. Cataract formation begins at the posterior pole of the lens and continues until the entire lens has been affected. Growth of the opacity may stop at any point. The rate of growth and the degree

of opacity are dependent upon the dose as well as the type of radiation. The threshold for detectable cataract formation in 2 Sv (sievert) (200 REM (roentgen equivalent, man)) for acute radiation doses and 15 Sv (1500 REM) for protracted doses.

### 526. Chronic Radiodermatitis.

Delayed, irreversible changes of the skin usually do not develop as a result of sublethal whole-body irradiation, but instead follow higher doses limited to the skin. These changes are a common complication in radiation therapy but they should be rare in nuclear combat unless there is heavy contamination of bare skin with beta emitter material from fallout, in which case beta-induced skin ulceration could be seen. The condition should be easily prevented with reasonable hygiene and would be particularly rare in climates where the soldiers were fully clothed (arms, legs, and neck covered). Table 5-V lists the degrees of radiation dermatitis for various radiation doses.

*Table 5-V. Radiation Dermatitis*

Radiation	Dose	Effect
Acute dose (mainly beta)	6 to 20 Sv (600 to 2000 REM)	Erythema only
	20 to 40 Sv (2000 to 4000 REM)	Skin breakdown in 2 weeks
	>300 Sv (30,000 REM)	Immediate skin blistering
Chronic doses	>20 Sv (2,000 REM)	Dermatitis, with cancer risk

## SECTION VI - INTERNAL IRRADIATION

### 527. Introduction.

- a. When radioactive materials are incorporated into the body and retained, significant radiation injury can be sustained by specific tissues in which the materials are concentrated or in some instances by the whole body. The primary factors which determine the type and degree of injury are the types and amounts of the isotopes deposited and the nature and energies of the radiation emitted.
- b. Each isotope follows a fairly specific biological pathway in the body. This pathway may be quite complex with several compartments and is determined by the chemical nature of the isotope. A given isotope may be concentrated or retained in a specific organ or tissue during the time it is in the body. It may be eliminated from the body, and the rates of elimination of different isotopes vary considerably. More than one isotope may be incorporated in the body at the same time, and the effects of a mixture of isotopes found in fallout would be additive.

- c. In this section, certain basic principles and factors governing isotopes in the body are discussed; these include their distribution, action, and elimination. The associated clinical problems are discussed in Chapter 6.

### **528. Incorporation of Radioactive Material.**

The basic routes of entry for isotopes are: inhalation, ingestion, and absorption through the skin. Following ingestion or inhalation, a given material may be absorbed into the blood stream, depending upon its volatility. Insoluble materials are not absorbed, except in extremely small amounts, and may be eliminated fairly rapidly directly from the respiratory and gastrointestinal tracts. However, under certain circumstances, insoluble materials can be retained at or near the original site of deposition, e.g., in the lungs or in wounds, or may be translocated to regional lymph nodes, where again they will constitute an internal radiation hazard. Only the very small particles of radioactive materials, 10 microns in diameter or smaller, are deposited in the alveolar airsacs.

#### **a. Inhalation.**

- (1) An insoluble material which is inhaled in the form of an aerosol will be deposited along the tracheobronchial tree. Much of it will be removed by the ciliary action of the mucosa lining most of the respiratory system, but a certain fraction, depending on the size, shape, and density of the particles, will penetrate down to the alveolar airsacs and remain. Only the very smallest particles penetrate that far; and so, the percentage of inhaled insoluble particles which are retained in the lungs is small, generally less than 25%. However, material so retained can be a considerable hazard to the lung, since it may remain for a long time. A portion of this material will be picked up by the lymphatic system draining the various pulmonary regions. It will then be collected by and remain in the lymph nodes of the lungs and still be a long-term hazard to lung tissue. A small fraction of the material may reach the blood stream and end up trapped in the reticuloendothelial system in various regions of the body and for certain isotopes, such as plutonium and strontium, also in bone.
- (2) If a soluble material is inhaled, it is absorbed very rapidly and completely, and often will not remain in the lungs long enough to cause significant damage. Once in the circulation, it will be distributed in the body in the same way as it would following any other mode of entry.

#### **b. Ingestion.**

- (1) An insoluble material which is ingested will remain in the gastrointestinal tract and become mixed in and part of the fecal material in the large bowel, with which it will then be eliminated. This includes swallowed material cleared from the upper respiratory tract and the tracheobronchial system by ciliary action. Insoluble material is not retained in the gut as it is in the lungs or in soft tissues, and the radiation hazard is limited in time to that required for transit and elimination, generally a matter of hours. As a result, the radiation hazard is negligible, unless the material includes a highly active gamma emitter. Normally, beta and alpha radiation from insoluble

radioactive material in the gut lumen will not cause significant damage. The few cells of the mucosa which are damaged slough off and are replaced rapidly. A gamma emitter on the other hand would be a whole-body hazard as long as it was in the gut. Highly radioactive fallout containing fission products emitting beta and gamma radiations could cause some gastrointestinal tract damage if accidentally ingested with contaminated foodstuffs or water. However, in most such instances, the whole-body exposure received from external gamma radiation in the area would be the controlling hazard.

- (2) When a soluble material is ingested, absorption is quite efficient. This is the most significant route of entry for the soluble isotopes in fallout, particularly when fallout-contaminated water or food is consumed. A number of fission products can become incorporated into vegetation and enter into complex food chains. In some instances, certain radioactive materials can be concentrated in these chains increasing the eventual hazard to humans.

c. *Transcutaneous Absorption.*

- (1) An insoluble material contaminating the intact skin can be an external hazard only if it is a gamma or beta emitter. It will not be absorbed into the blood stream and thus will not become an internal hazard. Conceivably, contamination of the skin with large quantities of gamma emitting materials could result in significant whole-body irradiation. This could occur when personnel have been subjected to heavy fallout contamination. However, this can be easily prevented by prompt removal of contaminated clothing and washing exposed areas of skin. If a wound is contaminated, insoluble material will tend to remain localized in the tissue at the wound site, unless removed by debridement. Some would be present within the eschar. This type of contamination should not cause a serious problem, unless it is particularly high in radioactivity. A small but measurable fraction of the material will be cleared from the wound site by lymphatic drainage. Most of this material will be trapped in the regional lymph nodes which drain the area of the wound, similar to that process described for the lungs.
- (2) Soluble material will be absorbed readily through wound sites and distributed within the body organs and tissues according to the usual metabolism of the stable isotope of the element in question. Some soluble materials, particularly tritium, will be absorbed rapidly and totally across the intact skin.

## 529. Elimination of Isotopes.

- a. A radioactive material must be eliminated from the body to remove its hazard. Detoxification, which is effective against materials which are chemical hazards, will not be effective since radioactivity is not modified by chemical changes. The methods of elimination include renal excretion for most soluble materials, elimination in the feces for materials which are retained in the gut or which can be secreted in the bile, and exhalation for volatile materials and gases. Chelating agents, e.g., calcium or zinc DTPA (diethylenetriamine pentaacetic acid), if

- administered soon after exposure, are effective in enhancing the elimination of certain radioisotopes. These materials are not very effective for radioisotopes which have been incorporated and fixed in organs and tissues, e.g., bone. Under conditions of nuclear war, chelation therapy is very unlikely to be used. (See 717e.)
- b. The rate at which a material is eliminated is usually expressed as the biological half-life. This is the time it takes for one-half of a given amount of material to be excreted or eliminated. During each successive half-life, an additional one-half is removed from the body. It is analogous, therefore, to the physical half-life. Not all materials follow a simple exponential elimination process, but this method of expression is sufficiently accurate to be applicable to most soluble isotopes. An exception which must be noted is the retention of insoluble heavy metals such as plutonium in the lungs and in bone. The rates of loss under these circumstances are not exponential and are very slow.
  - c. The biological half-time may be variable. A prime example of this is body water, the turnover of which can be as short as 4 days to as long as 18 days depending upon the state of hydration, volume of intake, and renal function. If tritiated water is incorporated into the body, the biological half-life is the factor determining the hazard since it is so much shorter than the physical half-life of about 12 years. Reduction of the biological half-life to a minimum by overhydration and the administration of diuretics has obvious value and is the recommended therapy in cases of exposures to tritium. Other isotopes cannot be cleared from the body as rapidly, and there is no adequate treatment available at present for increasing the rate of removal of a mixture of isotopes which would be incorporated into the body as a result of ingesting fallout contaminated food and water.
  - d. The overall hazard of materials which are eliminated exponentially will be a function of their physical and biological half-lives considered together. Whichever is shorter will become the primary factor. The effective half-life is usually determined and expressed by the following formula:

$$\text{Effective half-life} = \frac{\text{Biological half-life} \times \text{Radiological half-life}}{\text{Biological half-life} + \text{Radiological half-life}}$$

- e. The uptake by the body of radioisotopes can be blocked in some cases. For example, potassium iodide or iodate if given prior to or soon after an intake of radioiodine, will reduce the uptake of radioiodine by the thyroid gland. Similarly, orally administered Prussian Blue will reduce the absorption of cesium from the gut and Alginate will reduce strontium absorption. No policy exists which would allow for NATO forces to stock and issue chelators.

## CHAPTER 6

GENERAL MEDICAL EFFECTS OF NUCLEAR WEAPONS:  
DIAGNOSIS, TREATMENT, AND PROGNOSIS

## SECTION I - GENERAL

**601. Introduction.**

This chapter covers clinical aspects of the various medical problems which may be seen in modern warfare as a result of the use of nuclear weapons. Blast, thermal, and radiation injuries are discussed first. Combined injury is discussed as a separate subject because of the special problems which patients present when radiation sickness complicates other serious injuries. The psychological and public health aspects of nuclear warfare are also combined.

## SECTION II - BLAST INJURIES

**602. General.**

The types of blast injuries by nuclear weapons are more varied than those caused by conventional weapons and are the result of two basic mechanisms, either the direct action of the blast wave overpressures or the indirect action of flying debris or violent displacement of individuals against other objects. In addition, the blast injuries caused by nuclear weapons will frequently be complicated by associated thermal and/or radiation injuries. Finally, the number of casualties produced at any one time in a given area will be very much greater for nuclear weapons than for conventional weapons.

**603. Diagnosis.**

The treatment of blast injuries is generally not difficult unless there is unrecognized internal injury with slow hemorrhage. As noted, missile injuries will predominate. About half of the patients seen will have wounds of their extremities. The thorax, abdomen, and head will be involved about equally. Missile injuries of the thorax, neck, and the head will be responsible for a large percentage of deaths because these types of injuries have a high probability of immediate fatality. The missile injuries caused by nuclear weapons will, in general, be of the low velocity type, and surprisingly severe injuries may be survived since extensive soft tissue cavitation would not be a factor. These injuries can occur with or without perforating wounds of the abdomen or the chest.

**604. Treatment.**

The treatment of blast injuries, whether combined with other injuries or not, is best managed by applying accepted principles of combat surgery. Treatment is divided into four basic plans:

- a. *Resuscitative Phase.* Lifesaving resuscitative measures designed to prepare the patient

for definitive surgical treatment come first. These include the establishment of the airway assuring the adequacy of respiration, replacement of lost blood and fluids, and splinting of possible fractures, particularly those involving the cervical vertebrae. Some resuscitative measures must be started prior to evacuation from the battlefield, particularly if ground transportation is used rather than helicopter evacuation.

- b. *Surgical Phase.* Definitive surgery should be done after resuscitative measures have been used to improve the patient's condition in order to minimize the risk of surgery and anesthesia. Occasionally, lifesaving surgery must be done without delay, but normally there is time to prepare patients for surgery if they have survived long enough to reach a treatment facility.
- c. *Recovery Phase.* In the immediate postoperative period, patients require minimal movement. Transportation to other facilities should be delayed until the patient's condition has stabilized.
- d. *Convalescent Phase.* Patients in this phase of treatment should be evacuated back to specialized convalescent facilities in order to keep the patient load of forward surgical hospitals as low as possible. Many injuries may require a prolonged recovery period before the individual has recovered to the point where he/she can resume their duties. Both the convalescent and recovery phases will be more protracted with the addition of the radiation injury.

### SECTION III - THERMAL INJURIES

#### 605. General.

Many burn casualties may occur as a result of incendiary attacks on cities and military personnel in the field during conventional warfare. However, in nuclear warfare, burns could become the most frequent injury seen. Because of the complexity of burn treatment and the increased logistical requirements associated with the management of burns, they will constitute the most difficult problem faced by the medical service.

#### 606. Diagnosis.

Certain factors are of prime importance in the early evaluation of burns because of their relation to overall prognosis. These include:

- a. Area of the burn; expressed in percentage of body surface involved.
- b. Involvement of critical organs; i.e., head and neck, respiratory tract, genitalia, hands, and feet.
- c. Depth of burn; superficial (first- or second-degree), or deep (second degree) and full thickness (third degree).

#### 607. Area of Burn.

- a. The most accurate way to estimate the amount of tissue injury following a burn is to measure the extent of the body surface burned. However, direct measurement is not

generally possible or necessary, and a short cut method of estimating the percent of the body surface involved can be very useful. The "Rule of Nines" method is a simple and reasonably reliable guide in which the various parts of the body are divided into surface areas of 9% each (or multiples of 9%) as shown in Table 6-I.

- b. As the percent of the surface burned increases, morbidity and the probability of mortality increases sharply. Burns which cover 20% or more of the body surface can be fatal without treatment. Even with treatment, mortality from extensive burns will be high, particularly in the very young or the aged. Young healthy soldiers who have uncomplicated burns may survive even extensive involvement with proper care.
- c. Determination of the percent of the body involved will aid in planning resuscitative treatment and estimating fluid requirements during the first 48 hours after the burn injury. Patients with severe burns will suffer quite extensive fluid and electrolyte losses, resulting in severe hypovolemic shock requiring aggressive fluid replacement therapy as early as possible. An outline of a resuscitative program is given in the treatment section.

*Table 6-I. Rule of Nines for Establishing Extent of Body Surface Burned*

Anatomic surface	% of total surface
Head and neck	9 = 9
Anterior trunk	2 x 9 = 18
Posterior trunk	2 x 9 = 18
Upper limbs	9 ea = 18
Lower limbs	18 ea = 36
Genitalia and perineum	1 = 1

### 608. Involvement of Critical Organs.

When certain organ systems are involved, the clinical effects of burns can be quite serious in spite of the fact that only a small fraction of the body is involved.

- a. *Head and Neck Burns.* Burns of the face can be serious problems, even if the eyes are not involved. Burns of the head frequently are complicated by severe edema, which can result in respiratory obstruction. This can be quite serious when the inhalation of hot gases has occurred. It may be necessary to do tracheotomies on many of these patients.
- b. *Burns of the Respiratory Tract.* When hot gasses are inhaled, this very serious type of injury may be sustained. These injuries have a high probability of mortality if the burns extend deep into the alveoli. These patients are very fragile and may not tolerate early evacuation. Pulmonary edema may develop abruptly, without warning, requiring vigorous ventilator support. These injuries can be very difficult to manage.



- c. *Burns of Hands and Feet.* These can be very disabling and may require long hospitalization for extensive surgical care even though they are not life threatening injuries. These patients may not be able to care for themselves and, as a result, will require extensive nursing care.

### 609. Depth of Burn.

Burns are classified on the basis of the depth of the injury.

- a. *Superficial or Partial Skin Thickness Burns.* These are lesions in which the dermis is intact and only the epidermis is injured. When the injury is limited and only erythema occurs (such as in a sunburn), these are usually called first-degree burns. If blistering is seen, the injuries are called second-degree burns. Superficial burns are usually painful but will heal readily by epithelization unless infection occurs. Infection can convert a typical second-degree, superficial burn into a deep or full-thickness burn which will not heal by epithelization but rather by scarring. Second-degree burns will be very common in nuclear combat and may be the one most common injury seen.
- b. *Deep or Full-Thickness Burns.* Injuries involving the full thickness of the skin which cannot heal by epithelization are called third-degree burns. Instead, these injuries heal by scarring, and as a result there may be contraction and loss of function, particularly if extremities are involved. Extensive plastic surgery may be required to prevent or limit loss of function. The areas of a burn which are third-degree are usually painless, and this helps differentiate areas of third from second-degree when both are present. The earlier the diagnosis of the degree of burn is made, the sooner reconstructive treatment with skin grafting can be started. In general, however, in nuclear combat, early skin grafting will rarely be possible.

### 610. Treatment.

Initial treatment of burn patients will be resuscitative. When such patients are first seen, a simple plan of treatment must include: maintenance of airway with ventilating support as needed, adequate fluid therapy, and careful records of input and output.

- a. *Maintenance of Airway.* This is of particular importance in head and neck burns or in unconscious patients. If large numbers of patients are seen requiring transportation over long distances early in the postburn period, tracheotomies may have to be done on a routine basis. Tracheotomies done prior to the onset of edema are much easier to perform than when they are done after edema has resulted in respiratory obstruction. When only small numbers of patients require treatment, tracheotomies are rarely required.
- b. *Fluid Therapy.* The shock that is associated with an extensive burn will be severe, and survival of these patients depends upon adequate, balanced fluid replacement therapy. In combat, however, standardized methods of management are required. Standard formulae for determining the fluid requirements of burn patients have been developed and can be used in combat. The basic principle in these formulae is that the amount of fluid required is proportional to the percent of body surface burned

and body weight. The type of fluid used includes colloidal materials to replace the plasma constituents lost as well as electrolytes.

c. *Fluid Requirements for First 24 Hours.*

(1) Colloid solutions:  $0.5 \text{ ml} \times \text{body weight in kilos} \times \text{percent of body surface burned}$ .

(2) Electrolyte solutions:  $1.5 \times \text{body weight in kilos} \times \text{percent of body surface burned}$ .

(3) Additional fluids: 2000 ml 5-10% dextran in water.

d. *Example.* This formula, to meet the requirements of a 70-kg person with 30% body surface burn, would be:

Colloid:  $0.5 \text{ ml} \times 70 \times 30 = 1050 \text{ ml}$

Electrolyte:  $1.5 \text{ ml} \times 70 \times 30 = 3150 \text{ ml}$

Metabolic fluid (carbohydrates): 2000 ml

Total: 6200 ml

e. *Restrictions.* Certain restrictions on the application of this formula are required since it is only a guide.

(1) Fluid requirements for an injury involving more than 50% of the body surface should be calculated as if the burn were no more than 50%.

(2) 10,000 ml of fluid should be the maximum given in the first 24 hours.

(3) The first half of the fluid should be given more rapidly than the second; and the actual rate of administration should be adjusted according to urinary output.

(4) During the second 24 hours, the colloid and electrolyte given should be about one-half of that given during the first 24 hours. Again, the actual rate should be adjusted to maintain a reasonable urinary output. This is the single best clinical guide to use in determining the patient's actual fluid requirements.

(5) After the 3rd or 4th day, the patients will begin to resorb fluid from the edematous areas and will excrete it in large quantities. Administration of fluids to replace this loss is contraindicated. Excessive administration of fluids must be avoided during this time, and fluid intake can generally be reduced to that normally required for metabolic needs.

f. *Input and Output Records.* It is extremely important to accurately follow the input and output of fluids in burn patients. It would be impossible to modify fluid therapy according to individual needs without accurate records. Combat medical records, however, must be simple and should be attached to the patient so that they accompany him during evacuation. Medical planners must consider how to modify and improve combat medical records so that accurate input and output data on burn patients can be recorded. Most burn patients will require urinary catheterization, and this can aid considerably in recording urinary output rates accurately.

## 611. Care of Burn Wound.

Although first priority in patient care is resuscitation, proper care of the burn wound is essential both for survival as well as for optimum healing and preservation of function. In that regard, as soon as the patient's overall condition permits, after hospitalization, initial debridement and cleaning of the burn should be done. The main purpose of this treatment is to remove foreign material and dead tissue to minimize infection. Thorough irrigation and the application of topical antimicrobial creams such as argentic sulfadiazine and sterile dressings should complete the initial procedures. Special attention should be given to critical areas such as the hands and surfaces over joints.

## SECTION IV - RADIATION INJURY AND COMBINED INJURY

### 612. General.

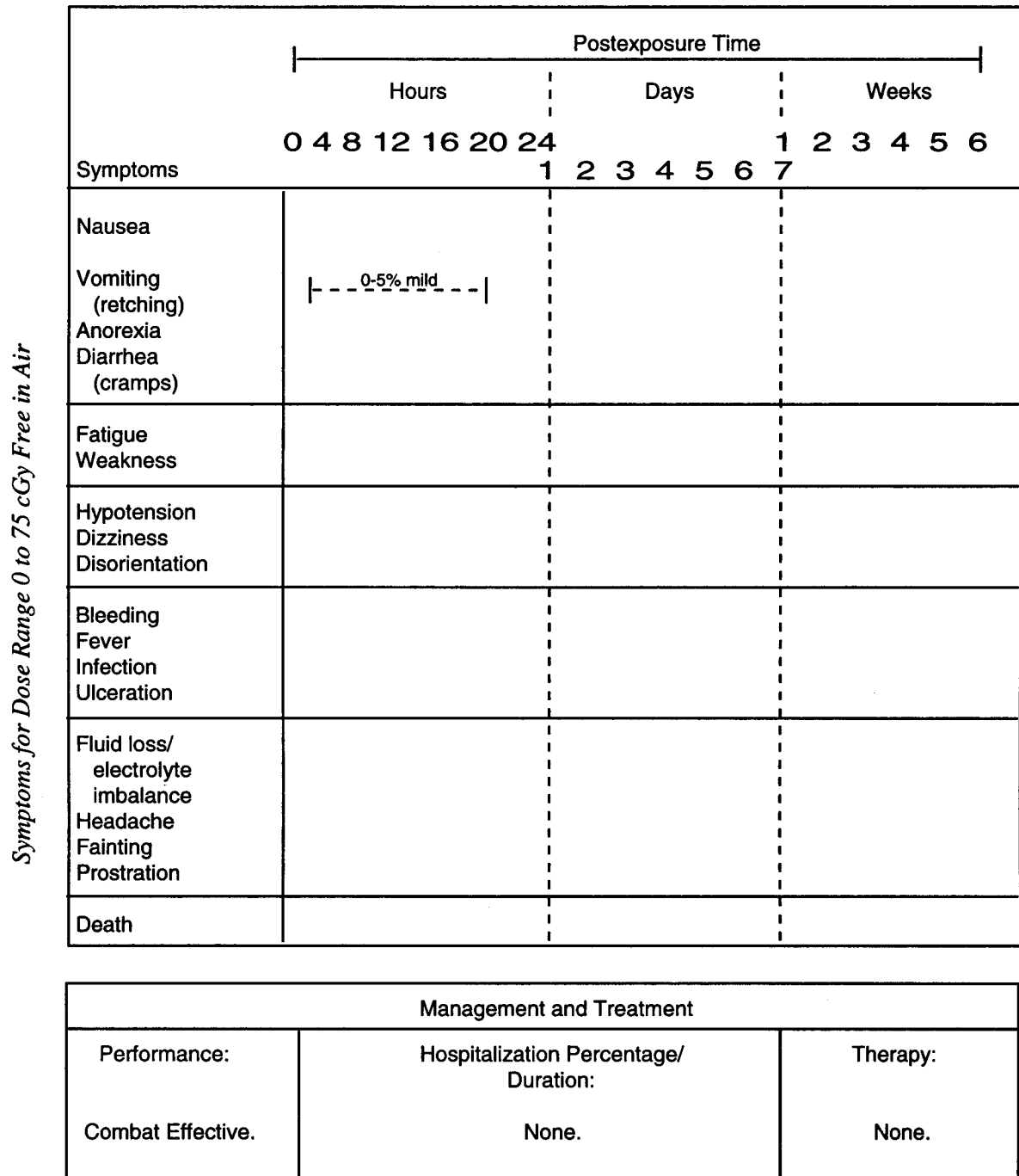
Radiation injury alone or in conjunction with other injuries or diseases will be common in nuclear warfare. Radiation injury can result from a single exposure to prompt radiation at the time of detonation of a nuclear weapon, from exposure to high levels of fallout radiation, or from repeated exposures to both with complex patterns of recovery from an accumulation of radiation damage.

- a. Whole-body irradiation, where absorbed doses are high and acquired over short periods of time, will result in acute radiation sickness. There are three characteristic syndromes which make up the typical clinical pattern of acute radiation sickness. These are the hematopoietic, gastrointestinal, and neurovascular syndromes which occur with increasing dose respectively.
- b. The hematopoietic syndrome, or syndrome of bone-marrow depression, occurs at lower doses than the others and would be the most common form of radiation sickness seen in nuclear combat. Manifestations of bone-marrow depression are seen following doses of radiation in the low through midlethal range. As the probability of lethality becomes 100 percent with higher doses, the gastrointestinal syndrome will predominate. This syndrome, which will also be common, develops from combined severe damage to bone marrow and the gastrointestinal tract. The neurovascular syndrome is associated with absorbed doses in the supralethal range and would be seen quite rarely since heat and blast effects would cause immediate lethality in most situations where the required very high radiation doses would be sustained. Exceptions could occur in aircrews exposed to prompt nuclear radiation from high altitude detonations and personnel protected against heat and blast in hardened sites below the surface or personnel in vehicles or shelters in the proximity of enhanced weapons' detonations. In these circumstances, an increase in the numbers of casualties receiving radiation doses in the supralethal range can be expected.

### 613. Clinical Course of Radiation Sickness.

The three syndromes described follow a similar clinical pattern that can be divided into three phases: an initial or prodromal phase occurring during the first few hours after exposure; a latent phase, which becomes shorter with increasing dose; and the manifest phase of clinical illness. The time of onset and degree of the transient incapacitation of the initial phase, the duration of the latent period, as well as the time of onset and severity of the clinical phase and ultimate outcome are all to a variable extent, dose dependent.

- a. *Prodromal Phase.* The initial phase of prodromal symptoms is characterized by the relatively rapid onset of nausea, vomiting, and malaise. This is a nonspecific clinical response to acute radiation exposure. It is not diagnostic of the degree of radiation injury; however, in the absence of associated trauma and an early onset, it does suggest a large radiation exposure. This radiogenic vomiting should not be confused with psychogenic vomiting which results from stimulation of the central nervous system by the sight/odor of blood, mutilation, vomitus, or excrement. The duration of this prodromal phase is short, generally a few hours, and the incapacitation should not be severe enough to warrant evacuation of military personnel away from their units.
- b. *Latent Phase.* Following recovery from the prodromal phase, there will be a latent phase during which the exposed individual will be relatively symptom-free. The length of this phase varies with the dose and the nature of the later clinical phase. The latent phase is longest preceding the bone-marrow depression of the hematopoietic syndrome and may vary between 2 and 6 weeks. It is somewhat shorter prior to the gastrointestinal syndrome, lasting from a few days to a week. It is shortest of all preceding the neurovascular syndrome, lasting only a matter of hours. These times are exceedingly variable and may be modified by the presence of other disease or injury. Because of the extreme variability, it is not practical to hospitalize all personnel suspected of having radiation injury early in the latent phase unless radiation injury has reliably been diagnosed. Instead, it is much more reasonable to wait until the onset of the phase of clinical illness or the development of significant hematopoietic suppression as indicated by the individual's peripheral blood profile.
- c. *Manifest Phase.* This phase presents with the clinical symptoms associated with the major organ system injured (marrow, intestine, neurovascular system). A summary of essential features of each syndrome and the doses at which they would be seen in young healthy adults exposed to short, high dose single exposures is shown in Figure 6-I. The details of the clinical courses of each of the three syndromes are subsequently described.



*Figure 6-I. Acute Clinical Effects of Single-Dose Rate Exposure of Whole-Body Irradiation to Healthy Adults (1 of 9)*

Symptoms for Dose Range 75 to 150 cGy in Free Air

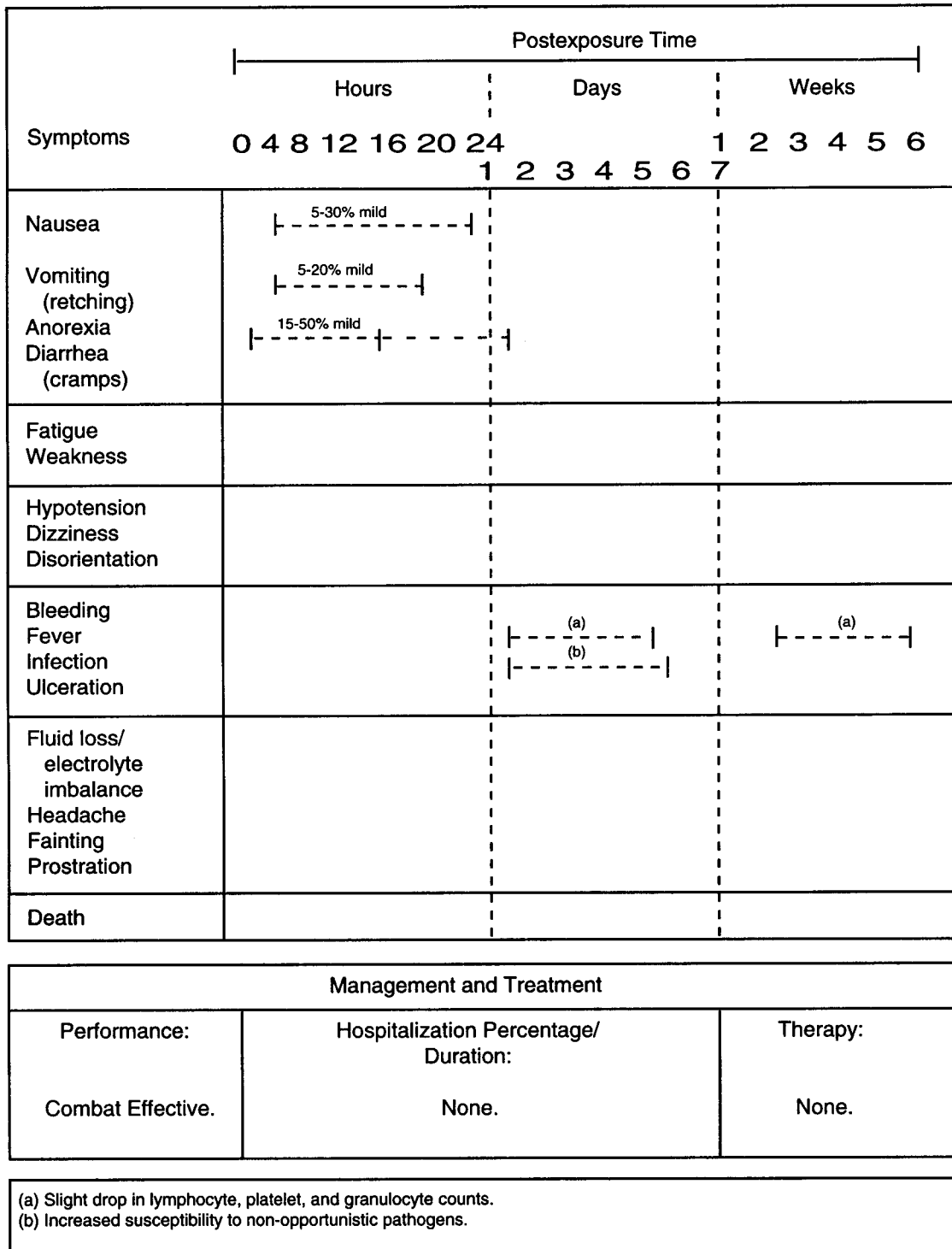


Figure 6-I. Acute Clinical Effects of Single-Dose Rate Exposure of Whole-Body Irradiation to Healthy Adults (2 of 9)

Symptoms for Dose Range 150 to 300 cGy in Free Air

Symptoms	Postexposure Time																		
	Hours						Days						Weeks						
	0	4	8	12	16	20	24	1	2	3	4	5	6	1	2	3	4	5	6
Nausea	30 to 70% mild to moderate																		
Vomiting (retching)	20 to 50% mild to moderate																		
Anorexia	50 to 90%																		
Diarrhea (cramps) (a)																			
Fatigue	30 to 60% mild to moderate												mild						
Weakness	30 to 60% mild to moderate												mild						
Hypotension																			
Dizziness																			
Disorientation																			
Bleeding													(b) 10% mild						
Fever													(c) 10 to 50% mild to moderate						
Infection							(d)												
Ulceration																			
Fluid loss/ electrolyte imbalance																			
Headache																			
Fainting																			
Prostration																			
Death													≤ 5%						

Management and Treatment		
<b>Performance:</b> DT:PD from 4 hours until recovery. UT:PD from 6 to 20 hours and from 6 weeks until recovery.	<b>Hospitalization Percentage/ Duration:</b> At 3 to 5 weeks medical care for 10 to 50 percent; survivors return to duty.	<b>Therapy:</b> Symptomatic treatment with antiemetics and antibiotics; hematologic surveillance.

(a) Ten percent of the Marshallese victims exposed to 175 rads (cGy) experienced diarrhea during the first exposure day. (b) Slight to moderate drop in platelets: from $3 \times 10^5/\text{mm}^3$ to $1.8\text{-}0.8 \times 10^5/\text{mm}^3$ . (c) Slight to moderate drop in granulocytes: from $6 \times 10^3/\text{mm}^3$ to $4.5\text{-}2.0 \times 10^3/\text{mm}^3$ . (d) Slight to moderate drop in lymphocytes: from $3 \times 10^3/\text{mm}^3$ to $2.0\text{-}1.0 \times 10^3/\text{mm}^3$ . Susceptibility to opportunistic pathogens.	CI = Combat Ineffective (less than 25% performance) PD = Performance Degraded (25 to 75% performance) DT = Demanding Task UT = Undemanding Task
---	--

Figure 6-I. Acute Clinical Effects of Single-Dose Rate Exposure of Whole-Body Irradiation to Healthy Adults (3 of 9)

Symptoms for Dose Range 300 to 530 cGy in Free Air

Symptoms	Postexposure Time																			
	Hours							Days							Weeks					
	0	4	8	12	16	20	24	1	2	3	4	5	6	7	1	2	3	4	5	6
Nausea	70-90% moderate																			
Vomiting (retching)	50-80% moderate																			
Anorexia	90-100%														60%					
Diarrhea (cramps)	= 10%-moderate														40-60% moderate					
Fatigue	60-90% moderate							mild							moderate					
Weakness	60-90% moderate							mild							moderate					
Hypotension																				
Dizziness																				
Disorientation																				
Bleeding															(a) 0-50% moderate					
Fever															(b)					
Infection								(c) 10-80% moderate												
Ulceration								(d)							30% moderate					
Fluid loss/ electrolyte imbalance																				
Headache																				
Fainting																				
Prostration																				
Death															≤5-50					
Management and Treatment																				
<b>Performance:</b> DT:PD from 3 hours until death or recovery. UT:PD from 4 to 40 hours and from 2 weeks until death or recovery.					<b>Hospitalization Percentage/ Duration:</b> At 2 to 5 weeks medical care for 10 to 80%. At low end of range less than 10% deaths; at high end, death may occur for more than 50%; survivors return to duty.					<b>Therapy:</b> Blood transfusion; antibiotics, rest; treatment with antiemetics.										
(a) Moderate drop in platelets: from $3 \times 10^5/\text{mm}^3$ to $0.8-0.1 \times 10^5/\text{mm}^3$ . (b) Moderate drop in granulocytes: from $6 \times 10^3/\text{mm}^3$ to $2.0-0.5 \times 10^3/\text{mm}^3$ . (c) Moderate to severe drop in lymphocytes: from $3 \times 10^3/\text{mm}^3$ to $1.0-0.4 \times 10^3/\text{mm}^3$ . (d) Epilation.															CI = Combat Ineffective (less than 25% performance) PD = Performance Degraded (25 to 75% performance) DT = Demanding Task UT = Undemanding Task					

Figure 6-I. Acute Clinical Effects of Single-Dose Rate Exposure of Whole-Body Irradiation to Healthy Adults (4 of 9)



Symptoms for Dose Range 530 to 830 cGy in Free Air

Symptoms	Postexposure Time																			
	Hours							Days							Weeks					
	0	4	8	12	16	20	24	1	2	3	4	5	6	7	1	2	3	4	5	6
Nausea	90-100% severe to moderate														60-100% severe					
Vomiting (retching)	80-100% severe to moderate																			
Anorexia	100%														100%					
Diarrhea (cramps)	~10% moderate to severe														60-100% moderate to severe					
Fatigue								90-100% moderate to severe												
Weakness								90-100% moderate to severe												
Hypotension															60%					
Dizziness															60%					
Disorientation															moderate					
Bleeding															(a) 50-100% moderate to severe					
Fever															(b) 60-100% moderate to severe					
Infection															(c)					
Ulceration															50% mild to moderate (d)					
Fluid loss/ electrolyte imbalance	40% mild to moderate														(e) 30%					
Headache	50% mild to moderate														moderate 50%					
Fainting															50%					
Prostration															60%					
Death															50-99%					
Management and Treatment																				
<b>Performance:</b> DT:PD from 2 hours to 2 weeks; CI from 3 weeks until death. UT:PD from 2 hours to 2 days and from 7 days to 4 weeks; CI from 4 weeks until death.					<b>Hospitalization Percentage/ Duration:</b> At 10 days to 3 weeks: medical care for 50 to 100%. At low end range death may occur for more than 30% at 6 weeks; at high end death may occur for 99% at 3 1/2 weeks.					<b>Therapy:</b> Blood transfusion, antibiotics; rest; antiemetic treatment. Some fluid replacement and electrolyte therapy may be required.										
(a) Severe drop in platelets: from $3 \times 10^5/\text{mm}^3$ to $0.1 \times 10^5 - 0/\text{mm}^3$ . CI = Combat Ineffective (less than 25% performance) (b) Severe drop in granulocytes: from $6 \times 10^3/\text{mm}^3$ to $0.5 \times 10^3 - 0/\text{mm}^3$ . PD = Performance Degraded (25 to 75% performance) (c) Severe drop in lymphocytes: from $3 \times 10^3/\text{mm}^3$ to $0.4-0.1 \times 10^3/\text{mm}^3$ . DT = Demanding Task (d) Epilation. UT = Undemanding Task (e) Mild intestinal damage.																				

Figure 6-I. Acute Clinical Effects of Single-Dose Rate Exposure of Whole-Body Irradiation to Healthy Adults (5 of 9)

Symptoms for Dose Range 830 to 1100 cGy in Free Air

Symptoms	Postexposure Time																		
	Hours				Days						Weeks								
	0	4	8	12	16	20	24	1	2	3	4	5	6	7	1	2	3	4	5
Nausea	100% moderate to severe												100% moderate to severe						
Vomiting (retching)	100% moderate to severe												100% moderate to severe						
Anorexia	100%												100%						
Diarrhea (cramps)	10% moderate to severe								100% moderate to severe										
Fatigue							100% severe												
Weakness							100% severe												
Hypotension													100% severe						
Dizziness	100% severe												100% severe						
Disorientation	100% severe												100% severe						
Bleeding							(a)						100% severe						
Fever							(b)						100% severe						
Infection							(c)												
Ulceration							(d)						100% severe						
Fluid loss/ electrolyte imbalance	80% moderate								(e)			80% moderate to severe							
Headache	80% moderate												100% moderate to severe						
Fainting													80% moderate to severe						
Prostration																			
Death													100%						
Management and Treatment																			
<b>Performance:</b> DT:PD from 1.5 to 8 hours; CI from 1 hour to 1.2 days; PD 1.2 to 10.4 days to death. UT:PD 2 hours to 3 days. Combat effective 3 to 4 days: PD from 4 to 14 days; CI from 14 days to death.					<b>Hospitalization Percentage/ Duration:</b> 4 to 6 days medical care for 100%; 100 % deaths at 2 to 4 weeks.					<b>Therapy:</b> Maintenance of electrolyte balance plus treatment recommended for lower doses.									
(a) Platelet count drops nearly to zero.					(b) Granulocyte count drops nearly to zero.					(c) Lymphocyte count drops nearly to zero.									
(d) Epilation.					(e) Moderate intestinal damage.					CI = Combat Ineffective (less than 25% performance) PD = Performance Degraded (25 to 75% performance) DT = Demanding Task UT = Undemanding Task									

Figure 6-1. Acute Clinical Effects of Single-Dose Rate Exposure of Whole-Body Irradiation to Healthy Adults (6 of 9)

Symptoms for Dose Range 1100 to 1500 cGy in Free Air

Symptoms	Postexposure Time																		
	Hours						Days						Weeks						
	0	4	8	12	16	20	24	1	2	3	4	5	6	7	1	2	3	4	5
Nausea	100% severe												100% moderate to severe						
Vomiting (retching)	100% severe												100% moderate to severe						
Anorexia	100% severe												100% severe						
Diarrhea (cramps)	10% severe												100% severe						
Fatigue							100% severe												
Weakness							100% severe												
Hypotension	80% mild (a)												100% severe						
Dizziness	100% severe												100% severe						
Disorientation	100% severe												100% severe						
Bleeding													(b) 100% severe						
Fever	30-45% moderate												(c) 100% severe						
Infection							(d)						(e) 100% severe						
Ulceration													(f) 100% severe						
Fluid loss/ electrolyte imbalance	100% moderate						(f)						100% severe						
Headache	100% moderate to severe												100% severe						
Fainting													70% moderate to severe						
Prostration													100%						
Death													100%						
<b>Management and Treatment</b>																			
<b>Performance:</b> DT:PD 1 to 5 hours; CI from 5 hours to 2 days; PD from 2 to 6 days; CI from 6 days to death. UT:PD from 1.5 hours to 8 days; CI from 8 days to death.			<b>Hospitalization Percentage/ Duration:</b> 3 to 6 days medical care for 100%; 100% deaths at 1 to 4 weeks. Hospitalization as early as first day may be required depending on severity of symptoms.						<b>Therapy:</b> Maintenance of electrolyte balance, in addition to treatment recommended at lower doses.										
(a) Blood pressure drops 25%; temperature increases to 102°F. CI = Combat Ineffective (less than 25% performance) (b) Platelet count drops to zero. PD = Performance Degraded (25 to 75% performance) (c) Granulocyte count drops to zero. DT = Demanding Task (d) Lymphocyte count drops to zero. UT = Undemanding Task (e) Epilation. (f) Moderate to severe intestinal damage.																			

Figure 6-I. Acute Clinical Effects of Single-Dose Rate Exposure of Whole-Body Irradiation to Healthy Adults (7 of 9)

Symptoms for Dose Range 1500 to 3000 cGy in Free Air

Symptoms	Postexposure Time																		
	Hours							Days						Weeks					
	0	4	8	12	16	20	24	1	2	3	4	5	6	7	1	2	3	4	5
Nausea	----- 100% severe -----							----- ----- ----- ----- -----						----- 100% severe -----					
Vomiting (retching)	----- 100% severe -----							----- ----- ----- ----- -----						----- 100% severe -----					
Anorexia	----- 100% -----							----- ----- ----- ----- -----						----- 100% -----					
Diarrhea (cramps)	----- 20% severe -----							----- ----- ----- ----- -----						----- 100% severe -----					
Fatigue	----- 100% severe -----							----- ----- ----- ----- -----						----- 100% severe -----					
Weakness	----- 100% severe -----							----- ----- ----- ----- -----						----- 100% severe -----					
Hypotension	----- 100% moderate to severe -----							----- ----- ----- ----- -----						----- 100% severe -----					
Dizziness	----- 100% severe -----							----- ----- ----- ----- -----						----- 100% severe -----					
Disorientation	----- 100% severe -----							----- ----- ----- ----- -----						----- 100% severe -----					
Bleeding	----- 45-80% moderate to severe -----							----- ----- ----- ----- -----  (a)  ----- ----- ----- ----- -----						----- 100% severe -----					
Fever	----- 45-80% moderate to severe -----							----- ----- ----- ----- -----  (b)  ----- ----- ----- ----- -----						----- 100% severe -----					
Infection	----- 45-80% moderate to severe -----							----- ----- ----- ----- -----  (c)  ----- ----- ----- ----- -----						----- 100% severe -----					
Ulceration	----- 45-80% moderate to severe -----							----- ----- ----- ----- -----  (c)  ----- ----- ----- ----- -----						----- 100% severe -----					
Fluid loss/ electrolyte imbalance	----- 100% moderate to severe -----							----- ----- ----- ----- -----  (d)  ----- ----- ----- ----- -----						----- 100% severe -----					
Headache	----- 100% severe -----							----- ----- ----- ----- -----						----- 100% severe -----					
Fainting	----- 100% severe -----							----- ----- ----- ----- -----						----- 80% severe -----					
Prostration	----- 100% severe -----							----- ----- ----- ----- -----						----- 80% severe -----					
Death	----- 100% severe -----							----- ----- ----- ----- -----  (e)  ----- ----- ----- ----- -----						----- 100% -----					

Management and Treatment		
<b>Performance:</b> DT:PD 1 to 2 hours; CI 4 hours to 3 days; PD 3 to 4 days; CI 4 days to death. UT:PD 1 to 7 hours; CI 7 to 25 hours; PD 25 hours to 4.5 days; CI 4.5 days to death.	<b>Hospitalization Performance/ Duration:</b> 3-4 days medical care for 100%; 100% deaths at 5 to 10 days.	<b>Therapy:</b> Maintenance of electrolyte balance, supportive treatment.

(a) Platelet count drops to zero.	CI = Combat ineffective (less than 25% performance)
(b) Granulocyte count drops to zero.	PD = Performance Degradation (25 to 75% performance)
(c) Lymphocyte count drops to zero.	DT = Demanding Task
(d) Severe intestinal damage.	UT = Undemanding Task
(e) Renal failure.	

Figure 6-I. Acute Clinical Effects of Single-Dose Rate Exposure of Whole-Body Irradiation to Healthy Adults (8 of 9)

Symptoms for Dose Range 3000 to 4500 cGy in Free Air

		Postexposure Time																			
		Hours						Days					Weeks								
Symptoms		0	4	8	12	16	20	24	1	2	3	4	5	6	7	1	2	3	4	5	6
Nausea		100% severe																			
Vomiting (retching)		100% severe																			
Anorexia		100%																			
Diarrhea (cramps)		30% severe						100% severe													
Fatigue		100% severe																			
Weakness		100% severe																			
Hypotension		100% severe																			
Dizziness		100% severe																			
Disorientation		100% severe																			
Bleeding		80-90% moderate						(a)					(b)								
Fever																					
Infection																					
Ulceration																					
Fluid loss/ electrolyte imbalance		100% severe																			
Headache		100% severe																			
Fainting								100% severe													
Prostration								100% severe													
Death								100%													
<b>Management and Treatment</b>																					
<b>Performance:</b> DT:PD from 6 to 20 minutes; PD from 20 to 90 minutes; CI from 90 minutes to death. UT:PD from 30 minutes to 3 hours; CI from 3 hours to death.		<b>Hospitalization Percentage/ Duration:</b>  At 6 hours to 1-2 days medical care for 100%; 100% deaths at 2 to 4 days. Symptomatic medical care will be required within the first hour.										<b>Therapy:</b>  Supportive treatment.									
(a) Granulocyte count drops to zero;										CI = Combat Ineffective (less than 25% performance)											
(b) Lymphocyte count drops to zero.										PD = Performance Degraded (25 to 75% performance)											
										DT = Demanding Task											
										UT = Undemanding Task											

Figure 6-I. Acute Clinical Effects of Single-Dose Rate Exposure of Whole-Body Irradiation to Healthy Adults (9 of 9)

**614. Hematopoietic Syndrome.**

- a. Patients who have received doses of radiation in the low to midlethal range will have depression of bone-marrow function with cessation of blood-cell production leading to pancytopenia. Changes within the peripheral blood profile will occur as early as 24 hours post irradiation. The exact time sequence of the depression of various circulating cell lines will vary. Lymphocytes will be depressed most rapidly and erythrocytes least rapidly. Other leukocytes and thrombocytes will be depressed somewhat less rapidly than lymphocytes. The time of onset of the depression of cellular production in the marrow will vary considerably, and the concomitant clinical problems of a tendency toward uncontrolled hemorrhage, decreased resistance to infection, and anemia will likewise vary considerably from as early as 10 days to as much as 6 to 8 weeks after exposure.
- b. A reasonable average time of onset of clinical problems of bleeding and anemia and decreased resistance to infection is 2 to 3 weeks. In general, the severity of the hematological depression will be dose dependent, and the more severe phases of bone-marrow depression will occur earlier. However, even lethal cases of bone-marrow depression may not occur until 6 weeks after exposure. The presence of other injuries will increase the severity and accelerate the time of maximum bone-marrow depression
- c. If the exposures leading to the bone-marrow depression are multiple, the time of onset of depression will be very difficult to estimate. The clinical picture, however, once bone-marrow depression is present, will be identical regardless of the sequence of exposure.
- d. The most useful laboratory procedure to evaluate bone-marrow depression is the peripheral blood count. A pancytopenia with particularly severe depression of lymphocytes, granulocytes, and thrombocyte will be strongly indicative of radiation-induced bone-marrow depression. (See Figures 6-II, 6-III, and 6-IV.) Bone-marrow studies will rarely be possible under field conditions and will add little information to that which can be obtained from a careful peripheral blood count.
- e. Patients will show signs or increased evidence of hemorrhagic disease and increased susceptibility to infection. If an infection occurs, there may be little clinical response because of the concomitantly depressed inflammatory response. The patients will lose weight, may lose hair and ultimately die from overwhelming infection and hemorrhage unless sufficient regeneration of the marrow occurs. Following lethal exposures, the marrow may be so damaged that recovery will be impossible.

**615. Gastrointestinal Syndrome.**

- a. The doses of radiation which will result in the gastrointestinal syndrome are higher than those causing the hematopoietic syndrome. An acute dose which will cause this syndrome would be at least 800 cGy measured in air. Under certain circumstances, lower doses may cause this syndrome, and conversely, exposures to high doses at low dose rates or as fractionated exposures may not cause it. Regardless of the dose

involved, the gastrointestinal syndrome has a very serious prognosis because it is almost always accompanied by nonrecoverable bone-marrow.

- b. The onset of the clinical phase of the gastrointestinal syndrome occurs earlier than that of the hematopoietic syndrome. After a short latent period of a few days to a week or so, the characteristic severe fluid losses, hemorrhage and diarrhea begin. The pathologic basis for this syndrome is an early physiologic derangement of the epithelial cells followed by a combination of severe loss of intestinal mucosa and injury to the fine vasculature of the submucosa. There is no specific clinical sign which is pathognomonic of radiation-caused gastrointestinal damage. However, a peripheral blood count done on these patients should show an early onset of a severe pancytopenia occurring as a result of the bone-marrow depression.
- c. A problem in diagnosis will arise in patients with sublethal hematopoietic depression due to radiation and diarrhea due to some other cause such as infection. It would be difficult to differentiate patients with lethal radiation sickness from those with potentially nonlethal radiation sickness complicated by dysentery. Microscopic examination of the diarrhea may reveal inflammatory cells which is suggestive of dysentery. Radiation enteropathy is not likely to result in an inflammatory response. It must be assumed during the care of all patients that even those with a typical gastrointestinal syndrome may be salvageable, until blood counts indicate that the bone-marrow depression is irreversible.

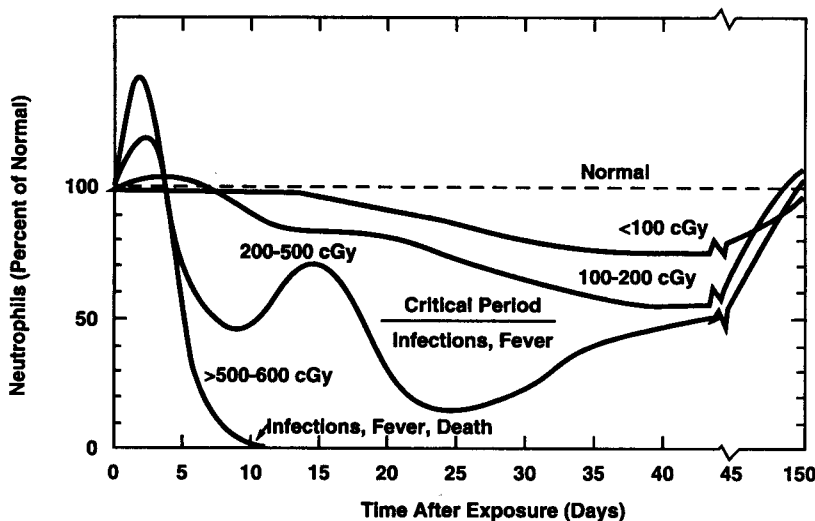


Figure 6-II. Smoothed Average Time-Course of Neutrophil Changes in Human Cases from Accidental Exposure as a Function of Dose

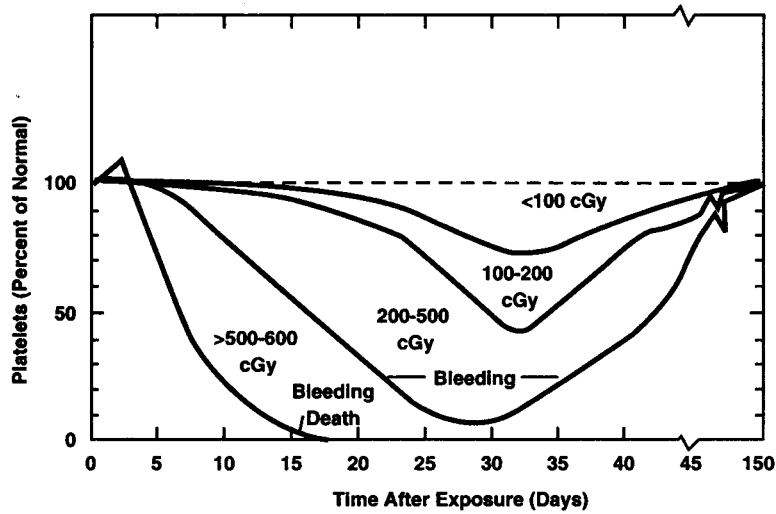


Figure 6-III. Smoothed Average Time-Course of Platelet Changes in Human Cases from Accidental Radiation Exposure as a Function of Dose

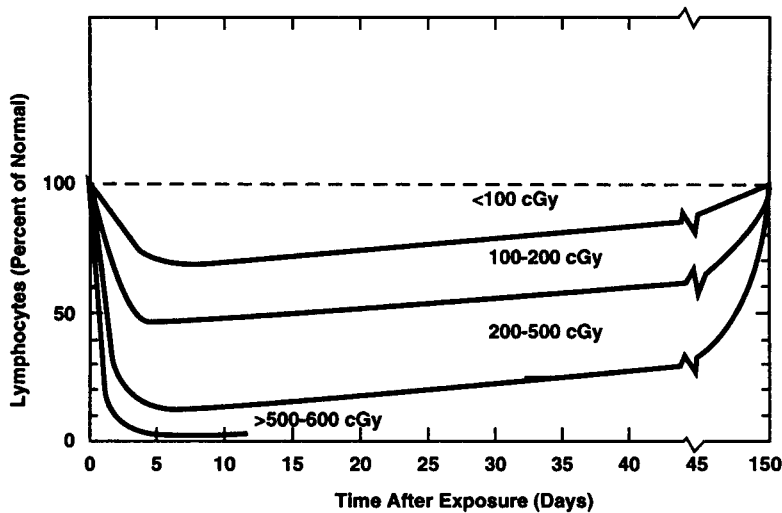


Figure 6-IV. Smoothed Average Time-Course of Lymphocyte Changes in Human Cases from Accidental Radiation Exposure as a Function of Dose

**616. Neurovascular Syndrome.**

This syndrome is associated only with very high acute doses of radiation. The lower limit is probably 2000 to 3000 cGy, although hypotension (significant decline in systemic blood pressure) maybe seen at even lower doses. The latent period is very short varying from several hours to 1 to 3 days. The subsequent clinical picture is basically that of a steadily deteriorating



state of consciousness with eventual coma and death. Convulsions may or may not occur. There may be little or no indication of increased intracranial pressure. Because of the very high doses of radiation required to cause this syndrome, personnel close enough to a nuclear explosion to receive such high doses would generally be well within the range of 100% lethality due to blast and thermal effects. However, in nuclear detonations above the atmosphere with essentially no blast, very high fluxes of ionizing radiation may extend out far enough to result in high radiation doses to aircraft crews. Such personnel could conceivably manifest this syndrome, uncomplicated by blast or thermal injury. Personnel protected from blast and thermal effects in shielded areas could also sustain such doses. Still, very few patients will be hospitalized with this syndrome.

### 617. Diagnosis.

- a. The diagnosis of radiation sickness is based primarily upon the clinical picture presented by the patient. A precise history of exposure may be very difficult to obtain, since many individuals may not know that they actually have been exposed to radiation, particularly if the exposure is due to fallout. The physical findings and characteristics of the various forms of radiation sickness are described below, along with such laboratory findings as may occur. Dosimetry, at the present time, will not give adequate information to determine either the extent of radiation injury or the prognosis. Dosimeters cannot tell whether a radiation exposure is whole body or partial body. They do not tell what the dose rate of the exposure was. Finally, they cannot differentiate between single exposures and multiple exposures unless read at regular intervals.
- b. These unknowns, coupled with the marked effects of age or physical condition, of concomitant disease, and of stress, etc., make it essential that physicians with the responsibility for treating patients in a hospital, base their treatment decisions primarily upon the actual clinical condition of the patient. However, in the mass casualty situation, decisions based on dosimetric data alone may be all that is practicable.
- c. Consequently, the following guidelines based on recent recommendations apply to medical personnel operating in austere field conditions. Lymphocyte levels may be used as a biologic dosimeter to confirm the presence of pure radiation injury but not in combined injuries. If the physician has the resources of a clinical laboratory, additional information can be obtained to support the original working diagnosis by the presence of prodromal symptoms. An initial blood sample for concentrations of circulating lymphocytes should be obtained as soon as possible from any patient classified as "Radiation Injury Possible" or "Radiation Injury Probable." After the initial assessment or at least no later than 24 hours after the event in question, additional blood samples should be taken for comparison. The samples may be interpreted as follows:
  - (1) *Lymphocyte levels in excess of 1500/mm<sup>3</sup> (cubic millimeters).* The patient most likely has not received a significant dose that would require treatment.
  - (2) *Lymphocyte levels between 1000 and 1500/mm<sup>3</sup>.* The patient may require treatment for moderate depression in granulocytes and platelets within 3 weeks postexposure.

- (3) *Lymphocyte levels between 500 and 1000/mm<sup>3</sup>* The patient will require treatment for severe radiation injury. The patient should be hospitalized to minimize the complications from hemorrhage and infection that will arise within 2-3 weeks postexposure.
  - (4) *Lymphocyte levels of less than 500/mm<sup>3</sup>*. The patient has received a radiation dose that may prove fatal. The patient needs to be hospitalized for the inevitable pancytopenic complications.
  - (5) *Lymphocytes not detectable*. The patient has received a superlethal radiation dose, and survival is very unlikely. Most of these patients have received severe injuries to their gastrointestinal and cardiovascular systems and will not survive for more than 2 weeks.
  - (6) *Other Guidelines*. A useful rule of thumb is, if lymphocytes have decreased by 50% and are less than 1000/mm<sup>3</sup>, then the patient has received a significant radiation exposure. In the event of combined injuries, the use of lymphocytes may be unreliable. Patients who have received severe burns or multisystem trauma often develop lymphopenia.
- d. It is difficult to establish an early definitive diagnosis. Therefore, it is best to function within a simplified, tentative classification system based on the three possible categories of patients noted in Table 6-II and discussed in the following.
- (1) *Radiation Injury Unlikely*. If there are no symptoms associated with radiation injury, patients are judged to be at minimal risk for radiation complications. These patients should be triaged according to the severity of the conventional injuries. If the patients are free of conventional injuries or disease states that require treatment, they should be released and returned to duty.
  - (2) *Radiation Injury Probable*. Anorexia, nausea, and vomiting are the primary prodromal symptoms associated with radiation injury. Priority for further evaluation will be assigned after all life-threatening injuries have been stabilized. Casualties in this category will not require any medical treatment within the first few days for their radiation injuries. Evidence to support the diagnosis of significant radiation injury in the absence of burns and trauma may be obtained from lymphocyte assays taken over the next 2 days. If the evidence indicates that a significant radiation injury was received, these casualties need to be monitored for pancytopenic complications.
  - (3) *Radiation Injury Severe*. These casualties are judged to have received a radiation dose that is potentially fatal. Nausea and vomiting will be almost universal for persons in this group. The prodromal phase may also include prompt explosive bloody diarrhea, significant hypotension, and signs of neurologic injury. These patients should be sorted according to the availability of resources. Patients should receive symptomatic care. Lymphocyte analysis is necessary to support this classification.

Table 6-II. Preliminary Triage of Casualties with Possible Radiation Injuries

Symptoms	Possible category of radiation injury		
	Unlikely	Probable	Severe
Nausea	-	++	+++
Vomiting	-	+	+++
Diarrhea	-	±	± to +++
Hyperthermia	-	±	+ to +++
Hypothermia	-	-	+ to ++
Erythema	-	-	- to ++
CNS dysfunction	-	-	- to ++

- = Absent  
+ = Present  
++ = Excessive  
+++ = Very Excessive

e. These symptoms frequently occur in whole-body irradiated casualties within the first few hours of postexposure.

- (1) *Nausea and Vomiting.* Nausea and vomiting occur with increasing frequency as the radiation exceeds 100-200 cGy. Their onset may be as long as 6-12 hours postexposure, but usually subside within the first day. The occurrence of vomiting within the first 2 hours is usually associated with a severe radiation dose. Vomiting within the first hour, especially if accompanied by explosive diarrhea, is associated with doses that frequently prove fatal. Due to the transient nature of these symptoms, it is possible that the patient will have already passed through the initial phase of gastrointestinal distress before being seen by a physician. It will be necessary to inquire about these symptoms at the initial examination.
- (2) *Hyperthermia.* Casualties who have received a potentially lethal radiation injury show a significant rise in body temperature within the first few hours postexposure. Although the number of cases is few, this appears to be a consistent finding. The occurrence of fever and chills within the first day postexposure is associated with a severe and life-threatening radiation dose. Hyperthermia may occur in patients who receive lower but still serious radiation doses (200 cGy or more). Present evidence indicates that hyperthermia is frequently overlooked. Individuals wearing a chemical ensemble will normally be hyperthermic; consequently, this will not be a useful sign.

- (3) *Erythema*. A person who received a whole-body dose of more than 1000-2000 cGy will develop erythema within the first day postexposure. This is also true for those who received comparable doses to local body regions, when the erythema is restricted to the affected area. With doses lower but still in the potentially fatal range (200 cGy or more), erythema is less frequently seen.
  - (4) *Hypotension*. A noticeable and sometimes clinically significant decline in systemic blood pressure has been recorded in victims who received a supralethal whole-body radiation dose. A severe hypotensive episode was recorded in one person who had received several thousand rads. In persons who received several hundred rads, a drop in systemic blood pressure of more than 10% has been noted. Severe hypotension after irradiation is associated with a poor prognosis.
  - (5) *Necrologic Dysfunction*. Experience indicates that almost all persons who demonstrate obvious signs of damage to the central nervous system within the first hour postexposure have received a superlethal dose. Symptoms include mental confusion, convulsions, and coma. Intractable hypotension will probably accompany these symptoms. Despite vascular support, these patients succumb within 48 hours.
- f. Casualties who have received a potentially fatal dose of radiation will most likely experience a pattern of prodromal symptoms that is associated with the radiation exposure itself. Unfortunately, these symptoms are nonspecific and may be seen with other forms of illness or injury, which may complicate the process of diagnosis. Therefore, the triage officer must determine the symptoms that have occurred within the first day postexposure, evaluate the possibility that they are indeed related to radiation exposure, and then assign the patient to one of the three categories: "Radiation Injury Unlikely"; "Radiation Injury Probable"; "Radiation Injury Severe." In the last two categories, the study of changes in circulating lymphocytes may either support or rule out the original working diagnosis. All combined-injury patients should be treated initially as if no significant radiation injury is present. Triage and care of any life-threatening injuries should be rendered without regard for the probability of radiation injury. The physician should make a preliminary diagnosis of radiation injury only for those patients for whom radiation is the sole source of the problem. This is based on the appearance of nausea, vomiting, diarrhea, hyperthermia, hypotension, and necrologic dysfunction.

### 618. Decontamination of Patient.

- a. Radiation injury per se does not imply that the patient is a health hazard to the medical staff. Studies indicate that the levels of intrinsic radiation present within the patient from activation (after exposure to neutron and high-energy photon sources) are not life-threatening.
- b. Patients entering a medical treatment facility should be routinely decontaminated if monitoring for radiation is not available. Removal of the patient's clothing will usually reduce most of the contamination. Washing exposed body surfaces will

- further reduce this problem. Both of these procedures can be performed in the field or on the way to the treatment facility. Once the patient has entered the treatment facility, care should be based on the obvious injuries. Care for life-threatening injuries should not be delayed until the decontamination procedures are completed.
- c. When radiation safety personnel are available, decontamination procedures will be established to assist in rendering care and to minimize the hazard from radioactive contaminants. A more extensive decontamination procedure is to scrub the areas of persistent contamination with a mild detergent or a diluted strong detergent. Caution should be taken to not disrupt the integrity of the skin while scrubbing because disruption can lead to incorporation of the radioisotopes into deeper layers of the skin. Contaminated wounds should be treated first, since they will rapidly incorporate the contaminant. Washing, gentle scrubbing, or even debridement may be necessary to reduce the level of contaminants.
  - d. Wearing surgical attire will reduce the possible contamination of health personnel. If additional precautions are warranted, rotation of the attending personnel will further reduce the possibility of significant contamination or exposure. The prevention of incorporation is of paramount importance. The inhalation or ingestion of radioactive particles is a much more difficult problem, and resources to deal with it will not be available in a field situation.

#### **619. Initial Treatment for Patients With Whole-Body Radiation Injury.**

- a. The primary determinants of survival among most patients receiving intermediate (serious but not uniformly fatal if treated) radiation doses is management of microbial infections and stopping any bleeding. If high intermediate doses have been received, fluid and electrolyte loss may cause early deaths. If properly resuscitated, however, these patients may survive until the consequences of hematologic failure become apparent.
- b. For those casualties who have received sublethal whole-body radiation doses, gastrointestinal distress will predominate in the first 2 days. Antiemetics (metoclopramide, dazopride) may be effective in reducing the symptoms, but present drugs available have significant side effects. Unless severe radiation injury has occurred, these symptoms will usually subside within the first day. For those patients who continue to experience gastrointestinal distress, parenteral fluids should be considered. If explosive diarrhea occurred within the first hour postexposure, fluids and electrolytes should be administered if available. For triage purposes, the presence of explosive diarrhea (especially bloody) is likely to be related to a fatal radiation dose.
- c. Cardiovascular support for patients with clinically significant hypotension and neurologic dysfunction should be undertaken only when resources and staff allow. These patients are not likely to survive injury to the vascular and gastrointestinal systems combined with marrow aplasia.

**620. Diagnosis and Treatment of Patient With Combined Injuries.**

- a. Conventional injuries should be treated first, since no immediate life-threatening hazard exists for radiation casualties who can ultimately survive. The patient with multiple injuries should be resuscitated and stabilized. During this process standard preparation for surgery will accomplish much radioactive decontamination. After surgery more definitive evaluation of radiation exposure can be initiated.
- b. In the event of a radiation accident or nuclear detonation, many patients will probably suffer burns and traumatic injuries in addition to radiation. The initial triage of combined injury patients is based on these conventional injuries. Further reclassification may be warranted on the basis of prodromal symptoms associated with radiation injury. The prognosis for all combined injuries is worse than for radiation injury alone. Animal studies indicate that when other injuries are accompanied by sublethal doses of radiation, infections are much more difficult to control, and wounds and fractures heal more slowly. Thus, potentially survivable burns and trauma will be fatal in a large percentage of persons who have also received significant injury from sublethal doses of radiation. Often with conventional injuries, staged reparative surgery is scheduled for 1-2 days after the initial surgery, and reconstructive surgery is still later. Because of the delays in wound healing and the subsequent granulocytopenia and thrombocytopenia with injuries from nuclear weapons, most of the life-saving and reconstructive surgery must be performed within 36 hours after the exposure. Then, if possible, no surgery should be performed for the next 1 1/2-2 months postexposure.

**621. Management of Infection.**

- a. In spite of antibiotics, infections with opportunistic pathogens are still a major problem. The majority of these organisms today are gram-negative like *Escherichia coli*, *Pseudomonas aeruginosa*, and many others. These infections occur as a consequence of both profound immunosuppression and abnormal colonization of body surfaces and invasive medical devices. Susceptible body surfaces include the oropharyngeal-respiratory tree and the intestine. Wound sites and artificial invasive devices such as catheters are also important sources of infection. Infections may be more prevalent and severe if patients are maintained for long periods in environments containing antibiotic resistant pathogens.
- b. Wound debridement, dressings, and, when necessary, antibiotics are key elements in infection control. Antibiotics, preferably in appropriate combination in therapy, should be used promptly to treat any new fever. When signs or symptoms of infection do appear in the granulocytopenic patient, treatment should be started without waiting for culture and sensitivity studies. Initial coverage should include gram-negative organisms and *Staphylococcus aureus*. Prevalent organisms and antimicrobial susceptibility patterns in the particular medical facility should also be considered. The drugs most often used now for the initial treatment are the synthetic penicillins, such as ticarcillin, combined with an aminoglycoside like tobramycin. It is recommended either that the treatment continue until the granulocytes return to

- more than 500 or treat for just 2 weeks and stop even if the white cell count is still low, as long as all signs of infection have cleared.
- c. Systemic antibiotic therapy for management of infection is as follows.
- (1) *Types of Agents.*
    - (a) Aminoglycosides such as gentamicin, netilmicin, tobramycin, and amikacin are the most effective.
    - (b) Ureidopenicillins and carboxypenicillins such as ticarcillin and piperacillin are less effective than the aminoglycosides, but are synergistic with them against gram-negative enterics.
    - (c) Monobactams are effective against gram-negative enterics, to a lesser degree than aminoglycosides, but have no renal toxicity as they do.
    - (d) Beta lactam resistant penicillins such as methicillin or dicloxacillin are effective for therapy of *Staphylococcus aureus*. Vancomycin can be administered for therapy of methicillin resistant *S. aureus*.
    - (e) Irnipenem (combined with cilastatin) is the only single agent that is effective against aerobic gram-positive and gram-negative organisms as well as anaerobic bacteria. However, some strains of *Pseudomonas* may be resistant.
  - (2) *Combination Therapy.* Several combinations have been advocated for the therapy of mixed aerobic-anaerobic infection, or for the therapy of gram-negative infections in the compromised host.
    - (a) *Gram-negative infection:* Aminoglycoside plus ureidopenicillins or carboxypenicillins; aminoglycoside plus a cephalosporin (second or third generation); aminoglycoside plus a monolactam.
    - (b) *Gram-positive infection:* Combinations of beta lactam resistant penicillin and an aminoglycoside.
    - (c) *Mixed aerobic-anaerobic infections:* An aminoglycoside or quinolone plus either clindamycin, cefoxitin, or metronidazole.

## 622. Future Concerns for Management of Radiation Injuries.

- a. Treatable radiation-associated injuries only include those with the hematologic and possibly, the gastrointestinal syndrome. Combined injuries would shift the treatable range of injuries to the lower radiation doses. Even in these ranges there is very little definitive information available now. Many approaches suitable for conventional injuries may be found of little utility in irradiated subjects.
- b. First actions in dealing with radiation casualties are to treat any conventional injuries first. Maintain ventilation and perfusion and stop hemorrhages. Most decontamination will be accomplished through routine management of the patient. Triage for radiation injuries followed by steps to prevent infection, fluid and electrolyte imbalance and bleeding will be necessary after patient stabilization. Unfortunately, there are limitations in the ability to effect these treatments successfully, particularly on a large scale with limited resources.
- c. Presently new means of radioprotection and repair of radiation damage are on the horizon. Furthermore, immunomodulators are now under study which may not only

facilitate marrow regeneration, but also help reduce the profound immunosuppression responsible for infections associated with severe injury. These agents may be used in combination with radioprotectors and antibiotics to further enhance survival. Leukopenia is a significant problem in irradiated casualties, but hazards exist with the transfusion of leukocytes into patients. Stem cell regeneration into selected populations probably offers the best opportunity to correct this deficiency. Although platelet transfusions are certainly desirable for radiation victims, they are presently not practical for mass casualty scenarios. A similar situation exists for bone marrow transplantation, although enormous progress is being made in autologous transplants. Again, stimulation of repair of surviving stem cells is probably the best near term hope of solving this problem. Problems of effective wound management and fluid and electrolyte replacement remain to be overcome in the neutropenic patient. Pharmacologic means to regulate performance decrements such as emesis and early transient incapacitation still are not available for use by military personnel.

- d. The foregoing should clearly show that much remains to be done to achieve effective treatment of radiation or combined injury victims. However, progress in this area is being made and the concerns outlined above will be resolved.

### **623. Effect of Radiation Injury on Response to Trauma.**

- a. At Hiroshima and Nagasaki, large numbers of patients with traumatic injury developed complications 2 to 3 weeks after exposure which were characteristic of the effects of bone-marrow depression. The open wounds of many patients stopped healing and became hemorrhagic. There was an associated loss of granulation tissue. Patients lost weight, and many died as a result of overwhelming sepsis. Those patients who recovered went onto normal wound healing after return of bone-marrow function. This would be the typical clinical picture in patients exposed to prompt radiation from small weapons, while at the same time sustaining thermal or blast injuries. The most common form of radiation sickness would be the hematopoietic syndrome, and the resultant hemorrhagic tendencies and decreased resistance to infection would complicate the healing of these patients' wounds. The overall result would be prolonged hospitalization and increased morbidity and mortality.
- b. Unfortunately, it will not always be possible at the time of admission to predict which patients with thermal or blast injuries would develop radiation sickness. A history of the prodromal symptoms which typically follow radiation exposure, as described previously, would be helpful but could not be relied upon. The first reliable indication that complications of radiation sickness might occur would be a lymphocytopenia, neutropenia, and thrombocytopenia noted in the peripheral blood count. By that time, however, the patient should have had at least the initial surgery required for his or her primary injuries. Subsequently, during the time the patients would be in the clinical phase of bone-marrow depression, careful supportive therapy would be required and elective surgical procedures should be avoided. Only those procedures that are actually required to save life and limb would be indicated.



If surgery is required during the clinical phase of radiation sickness, increased morbidity and mortality would be expected. This could be minimized by applying the basic techniques of meticulous surgical care such as are commonly used in noncombat surgery on patients with hemorrhagic disorders.

- c. Patients will also be seen who will have sustained their traumatic injuries and their exposures to radiation at different times. The best example of this would be patients wounded by conventional weapons before or after being exposed to fallout radiation. The interaction of the bone-marrow depression with traumatic injury is highly dependent upon this factor of timing. When patients are in the middle of the clinical phase of bone-marrow depression and are injured, the effect of this combination will be very deleterious, and a high mortality rate will be seen. If, on the other hand, the clinical phase of sickness comes late in the course of wound healing, a relatively small interaction will be seen.
- d. The degree of interaction between radiation sickness and traumatic injury will also depend a great deal upon the time course of the traumatic injury. Patients with small wounds that can be closed primarily, or with closed fractures which can be immobilized early, will not be as sensitive to the effects of radiation over as long a period of time as those patients with severe open wounds or burns. burn patients, in particular, will be susceptible to infection for an extended period of time and will be particularly sensitive to the decreased resistance to infection characteristic of radiation sickness. It will be expected then that the morbidity and mortality of burns combined with radiation sickness would be much greater than the morbidity and mortality following minor closed wounds and fractures. Open wounds and extensive soft tissue injuries would behave similarly.
- e. Radiation injury can be combined with a number of other clinical problems. Radiation sickness may be superimposed on underlying medical diseases, and such patients will also be more sensitive to the deleterious effect of radiation sickness. There have been indications that radiation sickness will allow otherwise nonpathogenic bacteria to become pathogenic and to cause significant disease. Further, patients with mild radiation sickness which might otherwise go unrecognized would be much more sensitive to environmental stresses or to the effects of chemical and biological agents.

#### **624. Effect of Injuries on Response to Radiation Sickness.**

- a. Many factors are responsible for relative radiation sensitivity. In any given population, some individuals will naturally be sensitive to irradiation and others will be relatively resistant. The factors which determine this are genetic as well as nongenetic. Age and physical condition are very important. The general condition of the individual at the time of exposure can modify the response to radiation considerably. There may be increased resistance to radiation if an individual has been exposed to a stressful stimulus such as a minor traumatic injury or environmental stresses prior to a radiation exposure. This phenomenon has been demonstrated in a number of laboratory studies with a number of animal species and a wide variety of stresses. Whether this applies to humans and to what degree is not

- known, but what can be said is that in combat situations that dose of radiation which would result in a given clinical response with a given probability is almost impossible to estimate.
- b. An example of this problem is the question of the  $LD_{50}$  for people. A specific  $LD_{50}$  for individuals in combat cannot be given except as a broad range. The  $LD_{50}$  for a young adult unstressed and subject to a single acute exposure of gamma radiation would probably be in the range of 450-500 cGy. There are indications that neutrons are more effective in producing lethality. (See paragraph 504b.) If the individual is stressed prior to radiation with a minor injury, the dose required to give a 50% probability of lethality maybe increased by 50% or more. If on the other hand the radiation exposure is followed by some other injury, the dose which would result in a 50% mortality might very well be decreased by a factor of two. If an individual is exposed to a number of low dose rate, small exposures such as would occur from repeated entry into fallout fields, the dose required to result in 50% mortality would be increased.
  - c. If the factors of age, different physical conditions, etc., are added, and a large group of individuals are exposed to a variety of radiation exposures, combined or not combined with a variety of stresses and injuries, the result is a range for the  $LD_{50}$  that could be from as low as 200 to 450 cGy. This is an estimate, and proof of this will only come from actual combat experiences. If the exposure is a low dose rate exposure received over a long period of time (as in the case of fallout), the  $LD_{50}$  dose range could be considerably higher than 450 cGy. But variations such as this are quite possible and indicate why personnel dosimetry cannot be used as an absolute indication of prognosis. This is summarized in Figure 6-V.
  - d. Dosimetry for an individual patient should only be considered as an aid to diagnosis and prognosis. The patient's clinical condition combined with appropriate laboratory investigation will indicate the prognosis much better. It is perfectly possible for patients with a total exposure of 1000 rads or more, as recorded by personal dosimeters, to survive if that exposure was accumulated over a long period of time and particularly if it is not whole body and the patient is a young healthy adult.

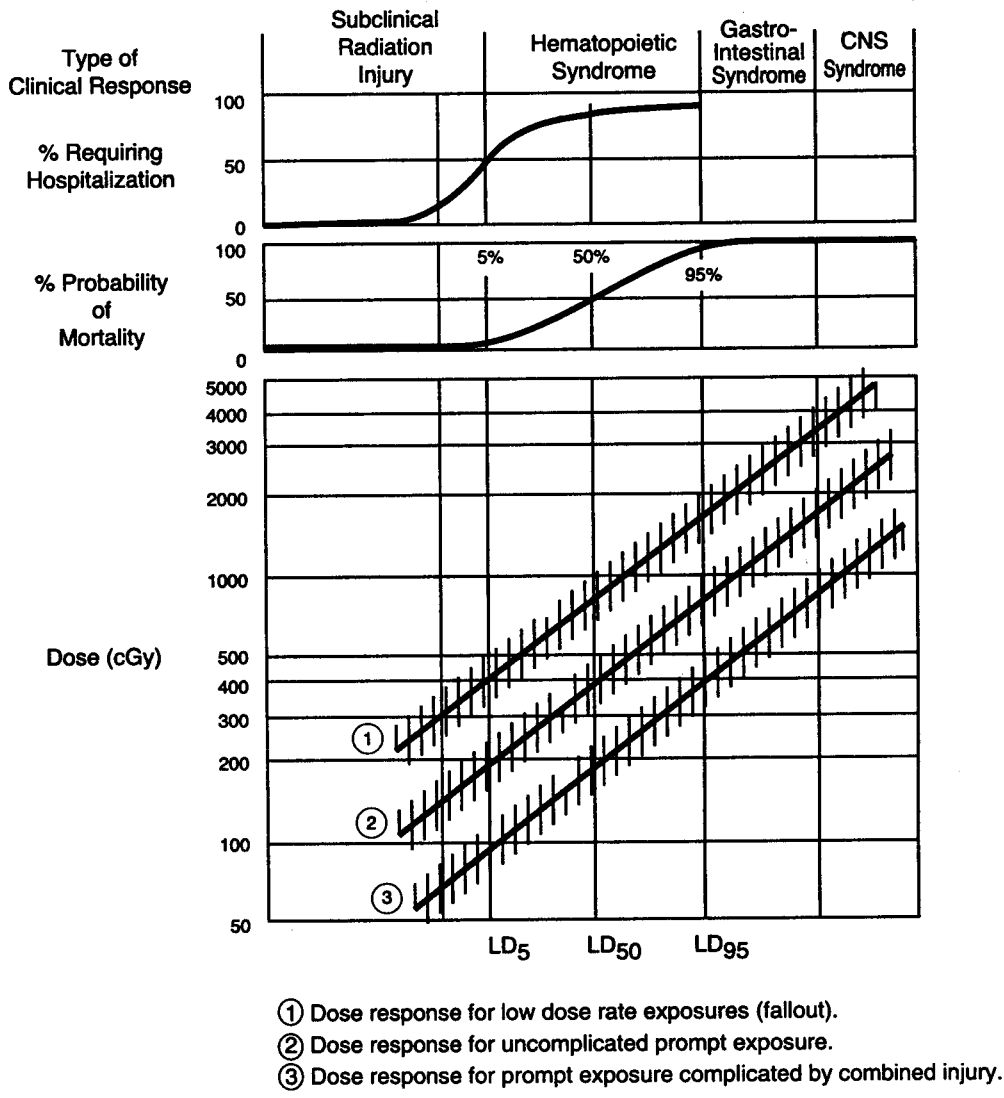


Figure 6-V. Clinical Effects of Whole Body Irradiation in Humans

SECTION V - PUBLIC HEALTH ASPECTS OF NUCLEAR WARFARE

625. Epidemic Disease Hazards Caused by Nuclear War.

a. For centuries the conduct and outcome of military operations have been profoundly affected by a small number of infectious diseases. The disruptive effects of war result in conditions conducive to increases in the incidence of these diseases, often in epidemic proportions. The use of nuclear weapons, with their potential for massive destruction, would produce situations in which epidemic outbreaks of disease among civilian populations would become highly probable. Enteric and

respiratory diseases would be particular problems. These, in turn, could present serious hazards to military forces in the area and serious problems for a military medical service, particularly when civilian medical facilities and personnel are inadequate to handle the problems.

- b. If large, heavily populated areas are devastated, the social organization which is required to effectively support a modern medical care system will be severely compromised. It is not until society reorganizes itself and rebuilds that a complex system such as modern medical care will resume. In past wars, military medical forces have provided for civilian populations and also the means for the rebuilding of a civilization ravaged by war. If the ravages of war are beyond the capabilities of either the society itself or the armies operating in the areas to repair, then the balance will be tipped in favor of decimation of the population by the classical diseases of disaster such as dysentery, typhus, typhoid fever, cholera, and plague. The results could be devastating to modern civilization.

## **626. Biomedical Impact of Nuclear Winter.**

The concept of what has been termed "Nuclear Winter" is a rather recent concern. This is a phenomenon that has attracted much attention but little serious research. In the early 1980's the issue was politicized for various reasons. Therefore, a considerable amount of conjecture and hyperbole has surrounded the discussion of nuclear winter. However, there are certain phenomena that will be experienced in large amounts of dust, smoke, and debris injected into the upper atmosphere. This cloud would have a tendency to absorb or scatter the sunlight thus decreasing the surface temperature over a portion of the earth. This could conceivably interfere significantly with the production of foodstuffs in these regions. There is an additional concern that in the event of a high air burst, the nitrogen in the upper atmosphere would be converted into oxides and the oxides, in turn, would combine with the ozone layer thus depleting the protective ozone. This would cause a significant increase in the amount of ultraviolet light capable of reaching the earth's surface. The ozone layer would eventually be reestablished. The combination of cooling, decreased ambient light, and increased ultraviolet light bombardment could have a significant impact on food production and perhaps energy consumption. Serious research is needed to attempt to quantify these effects.

## **SECTION VI - PSYCHOLOGICAL ASPECTS OF NUCLEAR WARFARE**

### **627. General.**

Although it is possible to estimate roughly the number of injured and dead which would result from the thermal, blast, and radiation effects of a nuclear explosion, it is much more difficult to predict the numbers and types of psychiatric patients. It is generally felt that the types of acute psychological problems which would occur in such circumstances would be essentially the same as those seen in other combat situations, and that the treatment methods which have been developed as a result of experience in past wars would be appropriate.

**628. Diagnosis.**

- a. The primary psychological abnormality which develops in severe stress or disaster situations is a transient, fluid state of emotional disruption. This occurs when individuals cannot cope with the danger presented to them by their environment. Its major features are fear and the results therefrom. The fear develops largely from the individual's inability to make meaningful decisions or initiate purposeful actions; and, as a result, even minor decisions become difficult to make. A vicious circle of fear-inaction-fear may ensue, and the individual involved may become ineffective. This may vary in degree all the way from very mild impairment of effectiveness to complete helplessness. Panic, defined as frantic, irrational behavior associated with real or supposed trapping, probably would be rare, since it has been found to be rare in other disaster situations. Precipitous flight with direction and purpose is not panic and should be considered a psychologically useful and practical response to the situation.
- b. The characteristic disturbances which would occur include: stunned mute behavior, uncontrolled flight, tearful helplessness, apathetic depression, inappropriate activity, increased tension, or preoccupation with somatic representations. These disturbances can last for minutes, hours, days, or sometimes weeks. Longer term reactions may include phobias, survivor guilt, and psychosomatic symptoms. Fortunately, patients with the milder and shorter disturbances are in the majority.

**629. Factors Determining Response.**

The frequency and severity of the psychological disturbances vary with several factors.

- a. *Intensity and Severity of Stress.* Stressful situations of brief duration are rather easily tolerated, and recovery of individuals with mild degrees of mental disruption under these circumstances is rapid. If stressful situations follow one another rapidly, or if any one of them is of long duration, then the probability of the occurrence of more severe psychological reactions of longer duration increase.
- b. *Degree of Personal Involvement.* If individuals have "close calls" or if they see close friends or relatives severely injured, their reactions will be more severe than if they remain relatively remote from danger.
- c. *Degree of Training.* This is the most important factor in that it is one which is most easy to modify. Well-trained individuals, who can react readily to dangerous situations and initiate appropriate actions, will develop a minimum of incapacitating fear. The fear they do develop will, if anything, help them, since it will be an integral part of a reaction of increased awareness or alertness allowing more efficient fight or flight.
- d. *Degree of Warning.* This is closely related to the above. Warning helps trained persons to prepare. They can initiate proper actions early. For untrained persons, the effect will be variable. If the fear is not incapacitating, then untrained persons who cannot react automatically to initiate proper actions may be able to utilize the time to improvise appropriate action. Whatever time they have to do this will help.
- e. *Presence of Leadership.* In a disaster situation, a few individuals will emerge as

leaders in a group. These may not be the appointed leaders, although in a military unit this is usually not the case unless the appointed or regular leaders become ineffective or are lost. When effective leadership is available, the group will fare much better than when there is none.

- f. *Group Identification.* This is a particularly important factor for the military. If group or unit integrity is preserved, the individuals in the unit will do much better. Also, those individuals with mild psychological disruptions will recover faster if they can remain with or close to their unit, thus retaining their personal relationship as a member of the unit.

### 630. Treatment.

- a. A major characteristic of these patients will be their suggestibility, and it is this which forms one of the basic underlying principles of treatment. The psychological disorders described do not require elaborate treatment and the best treatment is that which is simple, direct, and immediate. It should be done as far forward as possible, preferably within the unit to which the individual belongs. If this is not possible, then it should be started as soon as possible and in a medical facility close to the individual's unit. Evacuation to distant medical facilities is contraindicated. Evacuation tends to make the psychological problems worse by severing the patient's relationship with his or her group or unit and by introducing the element of "secondary gain" with the removal of the patient from danger.
- b. Treatment consists of
  - (1) Reassurance and suggestion that the situation will improve. These people are suggestible early in their disruptive phase and simple reassurance using a positive, direct approach is usually successful. The individual should be made to feel that he or she has an excellent chance of recovery, which, in general, is true.
  - (2) Rest with removal from immediate danger. A short period of rest in a safe area is of great benefit.
  - (3) Catharsis. Retention of fear and anxiety by the more severely incapacitated frequently blocks effective communication: When the patient expresses his or her feelings, this tends to remove the block. This communication is essential before the individual can recover enough to rejoin the activities of his or her group or unit.
- c. Psychiatrists are not always available to participate in the overall treatment of such patients. Therefore, all medical officers and their staffs should be familiar with these principles for managing the psychological problems arising from such disasters. The success of their actions will depend largely on how well the line commanders understand the program of managing this problem, since in a great degree the practical therapy of the mildly affected will be, in fact, the positive leadership actions taken by commanders.

**631. Prevention.**

The most important preventive factor is intensive training. The end result is less fear and more prompt effective action. Action relieves tension so that the fear response is less likely to become severe or incapacitating. Fear may not even develop to the point where the individual is aware of it. Other factors which contribute to prevention include discipline, morale, good leadership, and promotion of group identification. The beneficial results of effective command cannot be overemphasized.

## CHAPTER 7

## MEDICAL PLANNING AND OPERATIONS IN NUCLEAR WAR

## SECTION I - GENERAL

**701. Introduction.**

- a. In this chapter a variety of operational problems involved in providing medical support to a multi-national land, sea, and air force will be considered. The basic organization of such a force could vary, but an essential feature would be a unified command with a single overall plan of defense. Each nation would contribute military forces and logistic support to the land, sea, and air forces in varying amounts. The medical services of these military forces, however, could be called on to give support to other elements. Although it is a basic principle that casualties of a specific military force receive treatment by medical elements of that force, it must be understood that in a rapidly changing situation, casualties could be receiving primary care in hospitals of other forces or nations.
- b. The problems facing medical planners and commanders in preparing for operations on a nuclear battlefield can be divided into two distinct categories. The first category, staff-level planning and operational activities, includes those actions which must be accomplished prior to the initiation of a nuclear war to minimize the prompt effects of enemy nuclear attacks. The second category, unit planning and operational activities, includes those actions which must be accomplished at the unit level to minimize the immediate and delayed effects of enemy nuclear attacks in order to ensure continued effective medical operations in a nuclear environment. This chapter will address itself to some of the problems unique to these categories. This discussion is not intended as an authoritative treatment of the subject matter, but rather is presented as a guide which must be amplified and modified to meet the requirements of individual users.
- c. Medical commanders may expect at least 10-20 percent casualties (including fatalities) within a division-size force which has experienced a retaliatory nuclear strike. This prediction may be understated as many of the injured will be suffering combined injuries.
  - (1) Research with animal models has led to the conclusion that the prognosis of patients suffering combined injuries will be worse than the prognosis of patients suffering the same magnitude radiation exposure. In fact, the  $LD_{50/60}$  may be reduced from 450 cGy (free in air) to as low as 300 cGy (free in air).
  - (2) The inference from this information is that military personnel who receive subcasualty producing exposures of nuclear weapons effects might now require medical attention because they have received combined injuries.
- d. A nuclear weapons detonation can produce an effect which could adversely affect the capability of medical units, that being electromagnetic pulse (EMP). Unless military medical equipment developers ensure their critical electric or electronic equipment



is hardened against EMP effects, medical operations could be thrust into very primitive conditions.

- e. Planning for nuclear battlefields should be done within the context of biological and chemical warfare as it is perceived that an enemy may employ any variety of their weaponry at any given time.

## **SECTION II - STAFF-LEVEL MEDICAL PLANNING AND OPERATIONAL ACTIVITIES**

### **702. General.**

The success of medical support operations in nuclear war will depend to a great extent on the adequacy of planning, training, and preparation prior to the occurrence of hostilities. As evidenced in paragraph 701c, nuclear warfare is capable of producing a huge disparity between the available medical resources and the number of patients requiring treatment. This problem will be further complicated by disruption of lines of communication, isolation of medical units, and shortages of transportation, supplies, and equipment. Experiences gained during conventional wars will, in many instances, be applicable to the conditions on a nuclear battlefield. However, unique problem areas must be identified and methods of developing solutions sought by all available means, including the use of modern techniques of war gaining and operations research. Once these methods have been developed, a rigorous training and implementation program must be instituted at all levels of medical service for both professional and nonprofessional medical personnel. Emphasis must be placed on practical, problem-related training rather than on theoretical principles.

### **703. Organization of the Medical Support System.**

- a. Medical planners of each country must determine the type of organizational structure that best meets their country's individual and specific needs. Regardless of the type of organizational structure which is finally evolved, it must serve the functions for which it was designed and be responsive to the requirements of the armed forces it must support.
- b. The possibilities of destruction of major command and control units and or isolation of individual medical units are strong arguments for decentralization of control. However, decentralization must not be permitted to compromise the unity of the medical effort and conservation of medical resources. Both requirements can be met by the establishment of dispersed, semimobile, alternate command and control units, each of which is provided with communications systems. These control elements should be located reasonably close to other support activities. However, major logistical and tactical elements that might become targets for enemy nuclear strikes should be avoided. Some compromise must be made between:
  - (1) Convenience and immediacy of service to supported units prior to the outbreak of war; and
  - (2) The survival of medical assets so that care can be provided once war has begun.

**704. Mobility of Medical Support.**

Forward medical support elements should be fully mobile with organic transportation and communication systems. Medical elements and facilities located in "rear areas" will not require the same degree of mobility. However, these elements should be organized to obtain some degree of flexibility through the use of dispersed facilities and mobile augmentation teams to concentrate the medical effort in areas of the greatest need. Adequate provisions must be made for coordination with other support type elements to obtain the auxiliary support services which are essential to the accomplishment of the medical support mission.

**705. Coordination with Other Allies.**

Traditionally, direct medical support has been provided by the medical services organic to the armed forces of each country. This concept will require some modification in nuclear war to conserve medical resources and achieve maximum utilization of critical support services. In particular, cooperation between the medical services of different countries will be essential. Mutual medical support plans should be established between allied forces operating in adjacent sectors. Such plans should be simple and easily implemented and should include provisions for periodic review and revision to keep step with changes in troop levels and unit deployment. A key element in these plans is standardization of equipment and supplies. Standardization of color coding and other methods of identification, not dependent upon language, are essential. Key medical personnel in command and staff elements should establish liaison with their allied counterparts and should be kept aware of the amount and type of medical support available and planned.

**706. Casualty and Damage Assessment.**

- a. The staffs of combat units generally have an efficient system of casualty and damage assessment. Rear area support type facilities are generally lacking in this capability and may have problems in predicting the number of casualties as a result of an enemy nuclear strike. However, this information is necessary for adequate medical support and must be made available to medical staff officers. Further, the basic casualty estimations should be broken down into types of casualties in order that total bed requirements can be more accurately predicted, particularly in view of the prolonged hospitalization associated with the treatment of patients with burns and combined injuries. One enemy nuclear strike on a given area can produce casualties far in excess of the treatment capability of local medical resources. The effectiveness and adequacy of the rescue, evacuation, and treatment effort during the first 24 hours after such an attack are critical. Area commanders must be informed rapidly of the magnitude of the damage and the estimated medical load in order to provide rescue and treatment resources in sufficient quantities or request the proper assistance from higher headquarters, adjacent units, or allied units.
- b. Various systems of casualty and damage assessment have been developed. Most such systems are rather involved and depend on many variables such as method and time

- of delivery, type of burst, size of weapon, weather and climatic conditions, wind direction and speed, fallout dose rate, etc. The gathering and complication of such data are time consuming and may not be accomplished until many hours after the disaster. Consequently, medical planners must develop a system of casualty estimation which will provide rapid and reasonably accurate estimates of the number and types of casualties produced by a given enemy nuclear attack.
- c. An aerial reconnaissance and survey with photomapping of the target area is the simplest and most rapid way to estimate damage. By noting the degree of damage to structures within the target area, personnel trained in assessing physical damage from nuclear weapons can rapidly construct an area overlay depleting the radius from ground zero for selected blast and thermal parameters. By combining this overlay with other pertinent data such as population density, warning time, type of structures, time of day, etc., it is possible to rapidly predict the casualty load with a reasonable degree of accuracy.
  - d. Prompt radiation effects cannot be determined by aerial reconnaissance. However, significant prompt radiation, even from tactical size standard fission weapons (the size used in Japan), occurs only within the area of severe blast damage and hence alone does not exclusively create a significant number of patient casualties. As well, it is believed that enemy targeting is based upon maximizing the blast effect of nuclear detonations by use of air bursts. This would argue for their using relatively large yield weapons; weapons for which ionizing radiation is the least far-reaching effect. If the enemy develops and employs enhanced radiation weapons, one would predict a significant number of patient casualties suffering ionizing radiation exposures without other physical injury. Residual radiation does present a problem, both to survivors and to rescue and medical personnel coming into the area. Appropriate survey and protective measures must be taken to minimize this danger to survivors and rescue-medical personnel. Medical planners of each NATO country must consider the problems of casualty and damage assessment and develop a system which is best suited to their country's individual requirements.

### **707. Logistical Support System.**

- a. The success of medical support effort depends to a great degree on the adequacy of prewar logistical planning and preparation. Logistical plans should provide not only for medical supplies and equipment but also general supplies, food, clothing, water purification apparatus, radiation detection and measurement instruments, communications equipment, and modes of transportation.
- b. The location of medical resources is extremely crucial. Resources must be close to the area of probable greatest need without being concentrated in areas likely to become targets for enemy attack. This means that medical planners must compromise between dispersal and the capability of the logistical system to move supplies and patients. Medical planners should take advantage of the various stages of military preparedness, which may precede the actual outbreak of hostilities, to implement dispersal and augmentation plans which have been developed. Extensive pre-positioning during peacetime is not practical because of the problems associated

- with long-term maintenance of medical equipment and medications in storage.
- c. Conservation of limited supplies requires efficient stock control procedures. Modern automatic data processing systems can achieve the necessary degree of control when properly used. However, when automatic data processing equipment is employed, consideration must be given to the establishment of protected sites, alternate facilities, and hardening to reduce vulnerability. Only a limited number of computer facilities will be available, and their protection is essential. Their practicability in theaters of operation has not been demonstrated.
  - d. The supply system must also be prepared to provide for increased demands for certain types of medical and general supplies and equipment, e.g., whole blood, blood expanders, burn kits, dressings, individual protective clothing, decontamination equipment, radiac instruments, etc. Much careful thought must be given to both short- and long-range supply, equipment, and maintenance requirements.

### **708. Personnel and Medical Unit Requirements.**

It is highly probable that entire medical units including large hospitals will be lost or will become incapable of functioning because of large-scale losses in personnel and equipment. Hospitals should be dispersed away from potential nuclear target areas to improve the probability of these facilities surviving nuclear weapons attacks. This mitigation technique, however, cannot be relied upon to prevent significant loss of medical treatment capability. Consequently, planning for whole unit replacement must be considered. These units would come from existing military hospitals or from reserve civilian units, depending upon relative availability and the mobilization plans of the individual country.

### **709. Command Radiation Guidance.**

- a. Line commanders at all levels will require advice from medical advisors concerning the effects of accumulated doses of radiation on the health of their personnel and the hazards of potential exposures when operations must be conducted in areas contaminated with fallout. This advice must be practical and based upon an understanding of the requirements of the mission as well as knowledge of the diversity of human response to radiation. The effects of radiation must not be either minimized or exaggerated, and their proper place relative to the other hazards of combat must be understood.
- b. STANAG 2083 has been established, incorporating the most recent guidance on the operational effects of radiation exposures.
- c. If exposures can be maintained below 150 cGy by using the procedures prescribed in STANAG 2083, the overall effectiveness of combat units will not be significantly degraded. However, if the exposures become relatively large (as may occur when an aggressor uses nuclear weapons), then tactical commanders must be advised of their forces' capability to continue the fight. Figures 7-I and 7-II provide an estimate of the combat effectiveness of combat units as functions of *acute* dose and time postexposure. These figures have been developed from subhuman primate studies at the Armed Forces Radiobiology Research Institute (for times less than 60 minutes,

postexposure) and from an assessment of how radiation sickness signs and symptoms will affect the performance of combat tasks (for times greater than 60 minutes, postexposure). An expansion of the information contained in the figures is presented in Table 7-I. The prediction associated with those identified as being "combat effective" is that they will be suffering radiation sickness signs and symptoms of such a nature that they will be able to maintain their performance of at least 75 percent of their preexposure performance level. Those predicted as being "performance degraded" could be operating at a performance level between 25 and 75 percent of their preexposure performance. Those predicted as being "combat ineffective" should be considered as being capable of performing their tasks at 25 percent (at best) of their preexposure performance level. Of course, these predictions are based on combatants suffering only one stressor, that being ionizing radiation exposures. The prediction of performance capacity of those having received ionizing radiation exposures will now have to be considered together with how other stressors (conventional injury, endemic disease, continuous duty (sleeplessness), time in combat, fatigue, etc.) might affect the total performance capability of the force. Also, other refinements to the method should be considered; by example, the description of all tasks as being either physically demanding or physically non-demanding may be too simplistic. For instance, tasks which require great, continuous concentration (e.g., monitoring of radar screens) may not fit well into these gross categories.

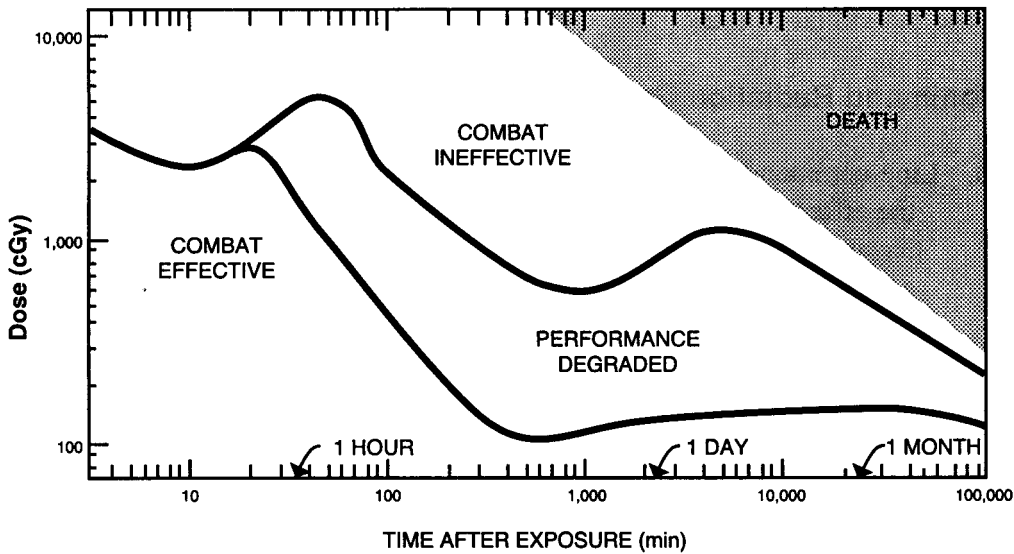


Figure 7-I. Expected Response to Radiation for Physically Demanding Tasks

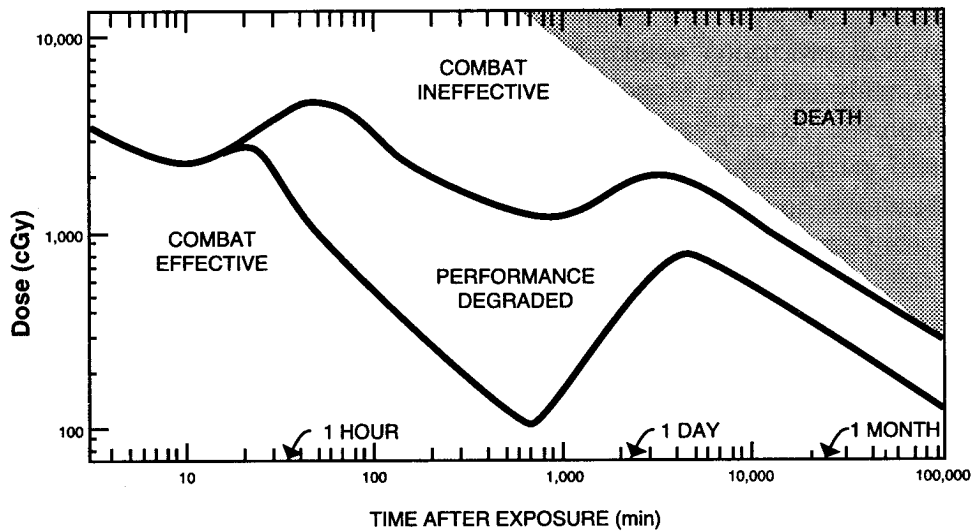


Figure 7-II. Expected Response to Radiation for Physically Undemanding Tasks

### SECTION III - MEDICAL UNIT PLANNING AND OPERATIONAL ACTIVITIES

#### 710. General.

Like the medical support system as a whole, the planning and operations of a field medical unit are keyed to the nature and functions of the forces the unit supports. While the problems to be confronted by medical units on the nuclear battlefield will be similar in some respects to those associated with conventional warfare, there are some dramatic differences. These include the vastly increased numbers of casualties to be handled, the need to operate in fallout, and the requirements to treat and decontaminate contaminated patients. These problems and other matters related to unit planning and operations are described in this section.

#### 711. Unit Mobility.

- a. With the changes in transportation capabilities and associated concepts of operations, the mobility of modern military forces has a tremendous impact on how a medical unit must function. It is essential that the medical facilities which are operating in close support of highly mobile forces be as mobile as those forces. This imposes severe restrictions on how long they can retain patients in one location. An efficient and flexible plan of evacuation is absolutely essential in order that forward medical facilities retain mobility.
- b. The classical concept of military medical care has been that a chain of surface or ground evacuation is available. Using helicopter evacuation, immediate casualty collection points may be bypassed so that wounded personnel can be taken directly

to well-equipped hospital facilities located relatively far to the rear reducing the need for an extensive ground evacuation system. However, reorganization of the medical evacuation system in which the intermediate elements are deleted, based primarily upon the proposed use of helicopter evacuation, may not be possible or desirable. Helicopter evacuation may become severely limited if nuclear weapons are used extensively, and the success of helicopter evacuation is certainly affected by weather conditions and enemy air capabilities. Therefore, a ground based evacuation system must be planned for, since it could easily become the primary means of evacuation.

*Table 7-I. Biological Response to Nuclear Radiation and Medical Care of Casualties*

Dose range (cGy free in air)	Onset and duration of initial symptoms	Performance (mid range dose)	Medical care and disposition
0 to 70	From 6 to 12 hours: none to slight incidence of transient headache and nausea; vomiting in up to 5 percent of personnel in upper part of dose range.	Combat effective.	No medical care, return to duty.
70 to 150	From 2 to 20 hours: transient mild nausea and vomiting in 5 to 30 percent of personnel.	Combat effective.	No medical care, return to duty.
150 to 300	From 2 hours to 2 days: transient to moderate nausea and vomiting in 20 to 70 percent; mild to moderate fatigability and weakness in 25 to 60 percent of personnel.	DT:PD from 4 hours until recovery. UT:PD from 6 to 20 hours; PD from 6 weeks until recovery.	At 3 to 5 weeks: medical care for 10 to 50 percent. At high end of range death may occur to more than 10 percent. Survivors return to duty.
300 to 530	From 2 hours to 3 days: transient nausea and vomiting in 50 to 90 percent; moderate fatigability in 50 to 90 percent of personnel.	DT:PD from 3 hours until death or recovery. UT:PD from 4 to 40 hours and from 2 weeks until death or recovery.	At 2 to 5 weeks: medical care for 10 to 80 percent. At low end of range less than 10 percent deaths; at high end death may occur for more than 50 percent; survivors return to duty.
530 to 830	From 2 hours to 2 days: moderate to severe nausea and vomiting in 80 to 100 percent of personnel. From 2 hours to 6 weeks: moderate to severe fatigability and weakness in 90 to 100 percent of personnel.	DT:PD from 2 hours to 3 weeks; CI from 3 weeks until death. UT:PD from 2 hours to 2 days and from 7 days to 4 weeks; CI from 4 weeks until death.	At 10 days to 5 weeks: medical care for 50 to 100 percent. At low end of range death may occur for more than 50 percent at 6 weeks. At high end death may occur for 99 percent of personnel.
830 to 3000	From 30 minutes to 2 days: severe nausea, vomiting, fatigability, weakness, dizziness, and disorientation; moderate to severe fluid imbalance and headache.	DT:PD from 45 minutes to 3 hours; CI from 3 hours until death. UT:PD from 1 to 7 hours; CI from 7 hours to 1 day; PD from 1 to 4 days; CI from 4 days until death.	1000 cGy: at 4 to 6 days medical care for 100 percent; 100 percent deaths at 2 to 3 weeks. 3000 cGy: at 3 to 4 days medical care for 100 percent; 100 percent deaths at 5 to 10 days.
3000 to 8000	From 30 minutes to 5 days: severe nausea, vomiting, fatigability, weakness, dizziness, disorientation, fluid imbalance, and headache.	DT:CI from 3 to 35 minutes; PD from 35 to 70 minutes; CI from 70 minutes until death. UT:CI from 3 to 20 minutes; PD from 20 to 80 minutes; CI from 80 minutes until death.	4500 cGy: at 6 hours to 1 to 2 days; medical care for 100 percent; 100 percent deaths at 2 to 3 days.
Greater than 8000	From 30 minutes to 1 day: severe and prolonged nausea, vomiting, fatigability, weakness, dizziness, disorientation, fluid imbalance, and headache.	DT and UT:CI from 3 minutes until death.	8000 cGy: medical care needed immediately to 1 day; 100 percent deaths at 1 day.

**Key:**

CI = Combat Ineffective (less than 25% performance)

DT = Demanding Task

PD = Performance Degraded (25 to 75% performance)

UT = Undemanding Task

**712. Rescue and Damage Control.**

- a. The location of the injured, when tactical units are dispersed and highly mobile or if rear area logistical units are severely hit, may be quite difficult, since nuclear detonations can be so devastating in their effects that groups of casualties can be produced without the means to communicate their location and medical needs. This problem can be prevented only by the establishment of extensive communications systems, with a reserve capacity, which are hardened against the effects of EMP. The efficiency and rapidity with which location, rescue, and evacuation of the injured are accomplished will significantly affect the numbers of military personnel returning to duty and the numbers of survivors from an enemy nuclear detonation.
- b. Rescue operations, damage control, and medical operations are complementary and should be closely coordinated. However, it should be borne in mind that even with outside medical augmentation, the medical load will be overwhelming and every effort should be made to conserve these resources so as to provide medical care for the maximum number of injured personnel. Therefore, medical unit personnel should not be taken from primary patient care duties and used to perform rescue and damage control operations. Rescue and damage control personnel should be designated, trained, and equipped to render basic lifesaving first aid.
- c. Rescue efforts may have to be conducted in the presence of fallout contamination or with the possibility of fallout arriving at a later time. Qualified radiation monitors should be available to evaluate radiation dose rates and provide specific recommendations to the commander as to the hazards present. Where there is radiological contamination, radiation dose rates may be so high that rescue operations become very hazardous, and must be conducted with caution by members of organized rescue squads specially trained and equipped to assess radiological hazards. Close coordination should be established between medical elements and rescue, evacuation, and damage control elements to facilitate establishing consolidated staging, treatment and evacuation sites in areas of relative safety from residual radiation, secondary explosions, fires, etc.

**713. Handling Large Numbers of Casualties.**

- a. When there are very large numbers of patients to be cared for, the application of effective techniques of evacuation, of efficient medical management, and particularly of efficient sorting and classification of patients becomes increasingly important in order to insure optimum utilization of available medical resources. The problem of handling large numbers of casualties is not limited to hospitals. It exists at all levels throughout the entire chain of medical evacuation, and the basic principles of triage and patient classification must be understood by all medical personnel. (See AMedP-7(A), paragraph 107.) Since situations vary so greatly, rigid classification procedures must be avoided. Flexibility in the application of these principles must be an established part of medical guidance and training.
- b. It may become necessary for all hospitals to be able to establish and operate a continuous minimal treatment facility as part of the regular operational plan. This



minimal treatment facility would be used to house those patients who cannot return to duty and who do not require or warrant hospitalization in the regular or intensive treatment part of the hospital. This is necessary since, whether patients in an evacuation chain are hospitalized or not, they must be held somewhere and accounted for. They must be housed, fed, and given at least minimal care, and they must be near definitive medical care so that they can receive additional medical treatment in an efficient manner when time and resources permit.

- c. In such a minimal treatment facility, the emphasis would be on self-care since the staffing would have to be minimal.

#### **714. Unit Operations in Fallout.**

- a. Whenever large areas are contaminated by fallout, operations of all units, including medical, will be hampered to varying degrees, depending upon the level of contamination. When a serious radiation hazard exists, medical unit commanders will be faced with the question of whether to continue operation and accept hazardous exposures to their personnel or to take shelter, an action which may seriously reduce their unit's ability to care for patients. In order to make the correct decision, they will require adequate information, and this, in turn, necessitates them having the following capabilities:
  - (1) An effective radiation monitoring capability to correctly measure the radiation hazard.
  - (2) The ability to make rapid estimates of the future dose and dose rates expected.
  - (3) Satisfactory communication with other units and higher headquarters to report the fallout situation and to receive fallout warnings, information, guidance, and orders.
- b. Data required to permit proper situation analysis and decision making include:
  - (1) Whether the unit is or will be in a fallout area.
  - (2) Expected time of arrival of fallout, or if the fallout has arrived, how long before it will essentially all be on the ground and radiation dose rates begin to decline.
  - (3) The maximum radiation dose rates expected.
  - (4) The adequacy of existing or immediately available facilities as fallout shelters.
- c. Evaluation of these data together with the operational situation permits proper command decisions to be made relative to moving the unit, diverting patients to other medical treatment units, moving into fallout shelters, or remaining in place and continuing normal operations.

#### **715. Performance of Mission in a Radiologically Contaminated Environment.**

- a. Medical units required to remain in areas of high dose rates can survive and continue their patient care activities if adequate shelter is available to shield against radiation. Many materials available on the battlefield afford substantial shielding (Table 7-II). Use of some of these materials, such as concrete, requires significant engineer

support and prior construction. Earth, however, affords excellent protection and can be-employed with a minimum of engineering effort.

*Table 7-II. Shielding Properties of Common Materials from Fallout Gamma Radiation*

Material	Half-value layer thickness*
Steel	2 cm
Concrete	6 cm
Earth	8 cm
Water	12 cm
Wood	22 cm

\* Thickness required to reduce the incident dose or dose rate by one-half.

- b. In some cases it is unnecessary to do any construction since there may be structures and terrain features already available which will afford excellent protection from radioactive fallout. Tunnels, caves, culverts, overpasses, ditches, ravines, and heavily constructed buildings are examples. In the case of existing buildings, below ground basements give the best protection. With a minimum of effort, windows and overhead floor can be sandbagged or covered with dirt to provide additional protection.
- c. It should be a matter of policy for mobile medical units to locate in or near existing shelter whenever possible. When either fixed facilities or mobile units are unable to locate near existing shelter, adequate shelter must be constructed. Elaborate shelters are not required since normally they need to be occupied continuously only during the period of high radiation dose rates.
- d. It will be very difficult to predict accurately the rate of fallout decay. Therefore, decisions relative to operations in fallout areas should be based on actual survey data. However, it will not be possible or desirable to expose personnel to do area monitoring when dose rates are very high. Therefore, a reliable method of estimating fallout decay is required. Assuming a single nuclear detonation, Table 7-III demonstrates a simple and reasonably accurate method of estimating residual radiation decay. It must be noted that these calculations are most accurate only after all fallout is on the ground and the dose rate is beginning to decrease.

Table 7-III. The 7:10 Rule for Residual Radiation Decay

Time after detonation (hr)	Amount of radiation remaining	Dose rate decay (cGy/hr)
1	-	1000
7	1/10	100
49	1/100	10
343	1/1000	1

## 716. Field Expedient Fallout Shelters.

a. There are a number of field expedient fallout shelters. The more common ones are briefly described and discussed below.

- (1) *The Dozer Trench.* Here a trench of about 2.7 meters wide and 1.2 meters deep is dug with the aid of a dozer. It is estimated that one dozer with its operator could cut six 30 meter trenches in about 5 hours. About 0.6 m of trench would be required for each person to be sheltered; thus, in 5 hours, shelters could be constructed for approximately 300 patients and personnel. Protection and comfort can be improved from unit resources as time passes by digging the trench deeper, undercutting the walls and erecting tents over some portions of the trench. Such trenches should provide adequate fallout shelter for most fallout situations.
- (2) *Dug-In Tents of a Mobile Hospital.* The tents of a mobile hospital could be dug in to a depth of approximately 1.2 meters and would provide more comfort than the dozer trench described in the above paragraph. Such dug-in tents, however, have two principal drawbacks. First, they offer far less radiation protection than dozer trenches and second, they require considerably more in the way of engineering efforts.
- (3) *Vehicle-Earth Shelter.* A very effective shelter, combining the use of unit vehicles and dirt, can be constructed for mobile medical units with organic transportation. For example, two large tents can be joined end to end and a shallow trench dug around them for the vehicles. The dirt is piled carefully on the outside of the trench. An additional 15-cm trench is dug for the outer wheels of the vehicles. This combination of dirt and vehicles can give as much as 80% protection if fallout contamination is collected and removed from inside the rectangle thus created. Tent liners and ponchos can be used for this purpose. This expedient method of erecting shelter requires about 2 hours to build and can be occupied or evacuated in a matter of minutes. As with other expedient shelter, it could be constructed at the time the unit occupies the position.

b. Regardless of the type of shelter employed, an effective system must be developed to accomplish certain actions required for the efficient operation of the shelter. In the case of medical units involved in the active care of patients, it is probably advisable

to separate the shelter management functions from those of patient care. Those individuals assigned the responsibility of shelter management must provide for such essential functions as radiological monitoring, safe food and water, monitoring water storage facilities to prevent leakage and contamination, arranging for sleeping facilities, controlling fire hazards, enforcing health and sanitation rules, and providing for waste disposal. Shelter management plans must be developed prior to occupying shelters and must be familiar to all assigned personnel.

### **717. Handling of Radiologically Contaminated Patients.**

When fallout occurs, insufficiently sheltered personnel will become contaminated. If these personnel are not wounded or sick, decontamination will be accomplished at unit level under common supervision and is not a medical responsibility. If wounded personnel become contaminated, hospitalization becomes more complicated, since fallout contamination can be hazardous both to the patient and to attending medical personnel.

- a. Radiologically contaminated patients are those whose outer body surfaces have been contaminated with fallout from a nuclear detonation. These fallout residues, in the form of dust, ashes, dirt, or mud, will be loosely adherent to the clothing and skin of the patient; and, once these residues have been removed, the patient does not present a radiation hazard. The patient will not be radioactive him or herself. Thorough and systematic patient decontamination will be required. However, decontamination should not precede or interfere with lifesaving procedures required to resuscitate a severely injured patient and prepare him or her for surgery. Instead, decontamination should be an integral part of these procedures. Furthermore, care must be taken to avoid the accidental formation of a real hazard due to the accumulation of contaminated waste material in the area where the decontamination procedures are carried out. Thus, effective procedures for decontamination, controlled by monitoring and associated with proper control of contaminated waste, must be developed and employed.
- b. There are three distinct hazards associated with radiologically contaminated patients. These are the whole-body gamma hazard, the beta contact hazard, and an internal hazard from inhalation and ingestion of contaminated material. Whether considered from the viewpoint of the patient or those who must handle and treat the patient, these hazards are not of equal importance. It is necessary to determine which is the most important, or governing hazard in order to determine the best way to handle the patients.
- c. Potentially, the most important hazard is the whole-body gamma since this radiation has a long range in air. However, the whole-body gamma hazard should be considerably reduced by the time the patient reaches a medical facility. Two factors account for this reduction: shake-off and radiological decay. Shake-off refers to the loss of contamination from the patient's outer body surfaces as he or she walks, is carried, or otherwise transported from the place of injury to the medical facility. Again, this is possible since fallout residues are loosely adherent. Radiological decay refers to the process by which radioactive material decays to form stable, nonradioactive elements. The decay of residual radiation associated with a nuclear

detonation is very rapid in the early hours after its formation. Additionally, the whole-body gamma hazard to persons handling the patient is several orders of magnitude less than the exposure to the patient due to geometric considerations.

- d. The beta contact hazard presents a significant problem, primarily to the patient. If radiological contamination is permitted to remain on the skin surfaces for extended periods of time (several hours to days), beta skin burns may occur. Resembling first- and second-degree heat burns, these burns affect only those skin surfaces directly in contact with the radiological contamination. Gently brushing or washing the particles off the skin will eliminate the hazard to the patient. Wearing rubber gloves and surgical masks, and practicing good hygiene, including dust removal will eliminate the hazard to medical personnel who must handle or treat the patient.
- e. Under conditions of nuclear war, the minute quantities of radioactive material which might be transferred to the mouth, inhaled, or absorbed through wounds, represent a very minor hazard in comparison with the other hazards, therefore, chelation therapy is very unlikely to be used.

### **718. Patient Decontamination.**

The practical decontamination of radiologically contaminated patients is easily accomplished without interfering with the required medical care. Ninety to ninety-five percent of the decontamination can be accomplished by simply removing the outer clothing and shoes. This can generally be accomplished prior to admission without interfering with medical treatment. Once removed, contaminated clothing can be placed in bags, tagged, and removed to a remote section of the medical facility to avoid creating a hazard due to concentration of such contamination. The clothing can be decontaminated or disposed of by qualified personnel as time permits. The second phase of decontamination consists of washing or wiping the patient's face and hands. This should leave the patient 98% decontaminated. This simple task can be accomplished prior to admission, later on the ward, or elsewhere in the medical facility as the situation dictates. The third phase of decontamination consists of washing the hair, or clipping the hair and washing the scalp. The third phase need only be accomplished if the patient arrives without headgear and/or monitoring indicates that the hair is contaminated.

**NATO HANDBOOK ON THE MEDICAL ASPECTS  
OF NBC DEFENSIVE OPERATIONS  
AMedP-6(B)**

**PART I - NUCLEAR**

**ANNEX A**

**RADIATION DETECTION AND MEASUREMENT**

**1 FEBRUARY 1996**

**TABLE OF CONTENTS**

	Page
Paragraph A.01. Introduction	A-3
A.02. General	A-3
A.03. Terminology	A-3
A.04. Radiation Detectors and Their Applications	A-4
A.05. Radiological Surveys	A-7
Figure A-I. Pocket Dosimeter	A-6
A-II. Radial Plot	A-9
A-III. Grid Plot	A-9

**THIS PAGE INTENTIONALLY LEFT BLANK.**



## ANNEX A

## RADIATION DETECTION AND MEASUREMENT

**A.01. Introduction.**

- a. The detection and repeated measurement of radioactive fallout fields produced by nuclear explosions will give important information affecting the operation of field medical units. In addition, medical personnel must be trained in the detection and measurement of patient contamination in order to prevent uncontrolled exposures of hospitals and personnel.
- b. The purpose of this Annex is to provide medical personnel with information on the basic principles of radiation dosimetry, the operation of radiation detection instrumentation, and the techniques used in performing radiological surveys.

**A.02. General.**

This Annex discusses some of the operating principles and applications of various radiation detection and measurement instruments that may be used by the military. Definitions and descriptions of terms used in connection with radiation detection and measurement instruments are presented first. The operating principles and applications of selected instrumentation are then described. Finally, basic techniques for performing radiological surveys are summarized.

**A.03. Terminology.**

- a. *Radiation Absorbed Dose (rad)*. The term “rad” is an abbreviation for radiation absorbed dose and is a measure of the energy deposited in matter by ionizing radiation. The International System SI (skin dose) unit for radiation absorbed dose is the Gray (Gy), (1 Joule per kilogram), 1 Gy = 100 rad; 1 centigray (cGy) = 1 rad. The cGy is a measure of absorbed dose in any material. Use of the term cGy is not restricted to x- or gamma radiation, but can be used for all forms of ionizing radiation, including particulate. Dose means the total amount of energy absorbed. The exposure could be single or multiple and either short or long in duration.
- b. *Dose Rate*. Dose rate is the dose of radiation *per unit time*.
- c. *Excitation*. Excitation is a change in energy level of an orbital electron and occurs when the energy lost by the incident radiation is insufficient to cause ionization. It can result from interactions involving incident photons of gamma or x-radiation or from inelastic collisions of particles. When the excited electron returns to its ground-state energy level, it must give off energy in the form of a photon of an electromagnetic radiation, which is usually of low enough energy to be detected with a photomultiplier tube.
- d. *Ionization*. Ionization is the separation of an electrically neutral atom or molecule into electrically charged components termed an ion pair. This is accomplished by

- removal of one or more electrons (negatively charged) from an atom or molecule which then becomes a positively charged ion.
- e. *Specific Ionization.* Specific ionization is the number of ion pair per unit distance formed along the path of a particle. The distance specified is usually centimeters. The density of ionization produced by a given particle is a function of its charge and its velocity. A more slowly moving particle spends more time in the vicinity of the atom or molecule, increasing the chance of ionization occurring. As an example, because of its slowness and charge, an alpha particle will produce thousands more ion pairs per cm of travel than an electron (beta particle) of the same energy (approximately 100 ion pairs per cm).
  - f. *Gas Amplification.* The gas amplification factor is defined as the ratio of the number of electrons collected by the anode to the number of electrons formed by the primary radiation interaction. If sufficient potential difference is applied across a detector's electrodes, the free electrons resulting from ionization are accelerated toward the anode with enough energy to ionize the neutral gas atoms that are in their path, resulting in secondary ionization. This secondary ionization or amplification in the gas can add many thousands of free electrons to the sensitive volume for each primary electron that was formed by the radiation.
  - g. *Pulse Height.* Pulse height, which is a quantitative measurement of current flow, depends upon both the gas amplification factor and specific ionization of a given radiation. Since alpha particles have the highest specific ionization, they will produce the largest pulses. Beta particles, having a specific ionization of about 1/1000 that of alpha particles of equivalent energy, will produce pulses about 1/1000 the amplitude of those produced by alpha particles.
  - h. *Free in Air Dose.* The term "free-in-air-dose" refers to the radiation which would be measured in air at a certain point. This differs from other radiation doses of importance that might actually be desirable to measure, such as midline tissue dose or dose to the blood forming organs. The differentiation is made since free-in-air-dose is exceedingly easy to measure with current field instruments, while the more meaningful dose may be estimated or determined by use of a scaling factor or conversion approximation. Military tactical dosimeters measure free-in-air-doses.

#### **A.04. Radiation Detectors and Their Applications.**

- a. Human senses do not respond to ionizing radiation. Accordingly, special instrumentation must be used for radiation detection and measurement. Since the degree of hazard from radiation to humans depends on the type of radiation, its energy spectrum, as well as the quantity to which a person has been exposed, radiation detectors used in the field must be capable of making qualitative as well as quantitative measurements.
- b. An ideal instrument for practical use in the field would have the following characteristics:
  - (1) Measure dose, or dose rate, in units directly applicable to the tissue of concern.
  - (2) Respond to only one kind of radiation at a time.

- (3) Have the desired sensitivity and accuracy, independent of the energy of the radiation.
  - (4) Be free of calibration and zero drift within reasonable times.
  - (5) Be free of extraneous effects from gravitational forces, temperature, humidity, chemical vapors, electrical and magnetic fields, shock, and so on.
  - (6) Have a short response or readout time.
  - (7) Indicate the occurrence of full-or off-scale readings if its range is exceeded.
  - (8) Have a means of field checking its operability.
  - (9) Have a means of indicating when it is inoperable.
  - (10) Be small, light, and rugged, particularly if it is a portable instrument.
  - (11) Be relatively trouble-free and require only infrequent, simple repair and maintenance.
- c. No single instrument at present has all the characteristics described. Accordingly, different types of instruments must be used depending upon the nature of the radiation hazard. The characteristics of some of the more commonly used detectors are summarized below.
- (1) *Ionization Chambers.* Ionization chambers measure dose and dose rate from gamma and x-radiations. A typical ionization chamber that measures total dose is the pocket dosimeter. It is the size of a large fountain pen. (See Figure A-I.) It has a chamber containing two electrodes, one of which is a quartz fiber loop free to move with respect to its mounting. Radiation entering the chamber causes ionization within the sensitive volume. The distance the fiber moves is proportional to the dose received in the chamber. Instruments of this type are sensitive to severe shock and humidity and small enough to be worn comfortably. The great advantage of this type of instrument illustrated, is that it can be read at any time without the aid of a supplementary charger-reader by simply holding it up to a source of light and looking into it.
  - (2) *Geiger-Mueller Counter.* Geiger-Mueller counters are normally used for detecting single ionizing events which take place within the sensitive volume of the counter. They are very rugged and sensitive to low levels of radiation. They are usually equipped with audible detection of radiation in the form of "clicks." Geiger-Mueller counters detect gamma photons or beta particles. Detection of gamma rays is less efficient than of beta particles. A discriminating shield is usually provided with Geiger-Mueller instruments which when opened admits both beta and gamma radiation. With the shield closed, only gamma is admitted. Use of the shield may permit qualitative differentiation between ionization caused by beta particles and that produced by gamma photons.
  - (3) *Proportional Counters.* Proportional counters are used to detect one type of radiation in the presence of other types of radiation or to obtain output signals greater than those obtainable with ionization chambers of equivalent size. Proportional counters may be used to either detect events or to measure absorbed energy (dose), because the output pulse is directly proportional to the energy released in the sensitive volume of the counter. Proportional counters are most widely used for the detection of alpha particles, neutrons, and protons.

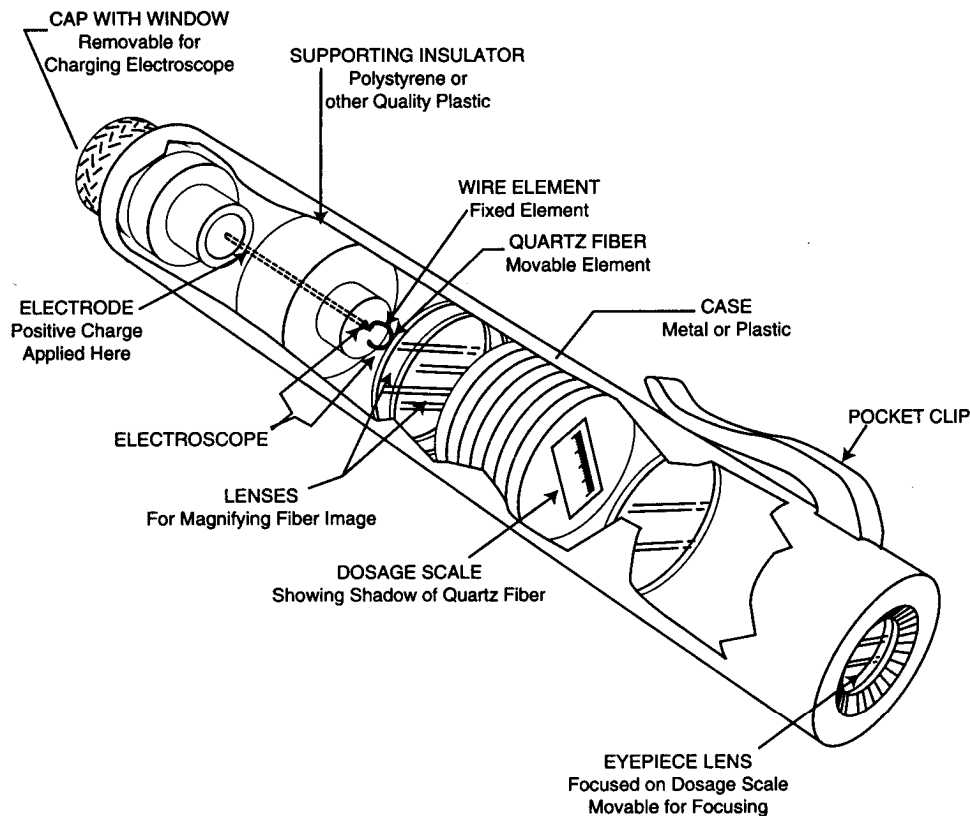


Figure A-1. Pocket Dosimeter

- (4) *Scintillation Counters.* A scintillation counter combines a photomultiplier tube with a scintillating material which may be a crystal or other phosphor (solid, liquid, or gas). Light pulses produced in the scintillator by radiation, releases photoelectrons from the cathode of the photomultiplier tube, which then initiates pulses of current that can be counted. Scintillation counters are available that can detect alpha and beta particles, gamma rays, neutrons, protons, and electrons. The most common for field use are those employed as alpha counters or as gamma detectors. Although very energy dependent, scintillation counters are more efficient at detecting low level gamma backgrounds than are Geiger-Mueller counters.
- (5) *Chemical Dosimeters.* Chemical dosimeters are systems in which measurable chemical changes are produced by ionizing radiation. Radiation produces acids in the system, the amount of which can be determined from visible color changes, or, more accurately, by titration or pH readings. Most chemical systems of practical size are useful only for gamma doses of hundreds to millions of cGy. However, small volume detectors can be found which measure doses in the range of a few cGy to several thousand cGy.
- (6) *Photographic Emulsions.* Photographic emulsions are frequently used as detectors. The film badge has been the most common dosimeter in use, but is

tending to be replaced by thermoluminescent dosimeters (TLD). The film badge uses the effect of radiation on photographic film to record dose. After film developing, the optical density is compared to a film calibration curve, and a measure of exposure dose is obtained. As the exposure dose increases, the optical density of the emulsion increases. At least two different types of film are employed to cover a wide-exposure range; a low exposure film, 0.02 cGy to 2 cGy and a high-exposure film, 1 cGy to 1,000 cGy. Metal filters such as aluminum, copper, and cadmium-tungsten, are used to increase the accuracy in the reading. The heavy metal filter also intensifies the gamma radiation interaction. Beta radiation is evaluated by observing the density change to a portion of film which is not covered by a filter. Film badges or TLDs are widely used as they provide an accurate means of recording radiation exposure at a low cost. Their disadvantage is that heat, moisture, and aging will cause a natural change in the films optical density.

- (7) *Thermoluminescent Dosimeters.* Thermoluminescent dosimeters (TLDs) detect radiations by the formation of a metastable crystalline structure with the valence electrons. Ionizing radiation excites valence electrons to a state within the crystal structure which can be detected by heating the crystal. When heated, the electrons are released from these traps and return to their lowest energy state with the release of light. The amount of light released is proportional to the radiation exposure. Radiophotoluminescent (RPL) glass is a dosimeter material that will luminesce following an excitation pulse of ultraviolet light if it has been exposed to ionizing radiation. This effect is caused by radiation induced changes in the glass crystalline electronic structure. Although other materials also exhibit this property, silver activated RPL glass has found the greatest application in x and gamma radiation dosimetry. The sensitivity depends on the type and manufacturer selected, and ranges from 0.01 cGy to several million cGy. This type of dosimeter cannot be zeroed; it gives a total cumulative dose reading that fades only very slowly with time. Silicon diodes are most useful for high energy neutron dosimetry. Neutrons reacting in the diodes cause displacement of atoms in the silicon crystal which results in a relatively permanent and measurable change in its electronic resistance. These dosimeters are almost totally insensitive to x and gamma radiation and have a practical range of 1 to 1000 cGy depending on the type selected.

#### **A.05. Radiological Surveys.**

- a. The primary purpose of performing radiological surveys is to determine the extent of any existing health hazards, establish protective control boundaries, and provide data on which to base decontamination requirements. Various types of radiological surveys may be performed. Area surveys may involve the determination of fallout patterns on the ground, levels of airborne activity, or contamination patterns on ships or in buildings. The results of area surveys are used primarily to establish protective control boundaries. Personnel surveys are performed to detect the presence of

- contaminated material on the body's surfaces, in body openings, e.g., nose and ears, or in the case of casualties with traumatic injury, contamination in wounds. The results of personnel surveys are used to evaluate health hazards and to establish decontamination requirements. Equipment/material surveys are conducted primarily to establish requirements for decontamination.
- b. The performance of a radiological survey may be divided into two phases; a preparatory phase, and an execution phase. The preparatory phase involves the selection, testing, and if necessary, calibration of survey equipment to be used; the acquisition of materials necessary for recording survey results, establishing communication links between the survey team and survey command center, and finally the outfitting of personnel who are to perform the surveys. Outfitting may involve the use of protective clothing.
  - c. A variety of techniques may be used in performing a radiological survey. Which specific techniques are employed will depend on the operational situation. However, certain basic principles can be described that are applicable to area, personnel, and equipment/material monitor surveys. These principles are outlined below.
  - d. The principle objective in an area survey is to establish the location and radiation levels associated with one or more isodose rate lines. An isodose rate line is a plotted contour line that depicts the location of some uniform level of radiation or radioactive contamination.
  - e. Two methods of plotting isodose rate lines are illustrated in Figures A-II and A-III. The radial plot is the simpler of the two and can be done quickly with minimum personnel. The grid system is more accurate, but it is time consuming and requires a large number of personnel to cover a large area. In practice, both methods might be employed using the best features of each system. The radial plot is used to establish the isodose rate line boundaries and the grid system is used to plot heavily contaminated areas in detail. Care must be used in selecting a focal point for a radial plot as the entire contamination area may be missed. Whatever system is used, the following rules must be observed:
    - (1) Isodose rate lines must always close.
    - (2) Isodose rate lines cannot cross each other.
    - (3) Isodose rate lines can cross a survey line only at a data point.
  - f. To perform an area survey, personnel move into an area until the radiation level established as a guide in the preparatory phase is reached. That point is then designated on a map. Following the readout from the radiation instrument, the isodose rate line for that radiation level is followed to the left or right as terrain dictates until the isodose rate line closes, i.e., a survey team having moved to its right eventually returns to the location in which the first reading was taken and plotted. Having completed this isodose rate line, higher or lower levels of activity are selected and other isodose rate lines are established.

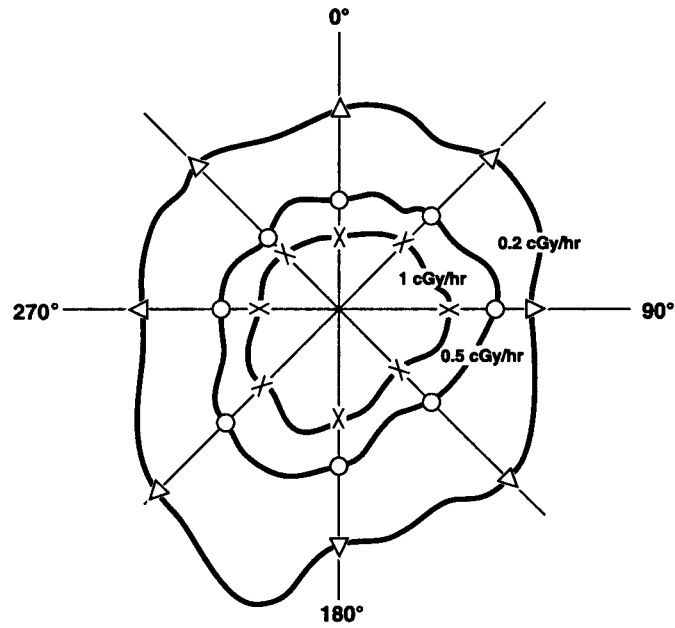


Figure A-II. Radial Plot

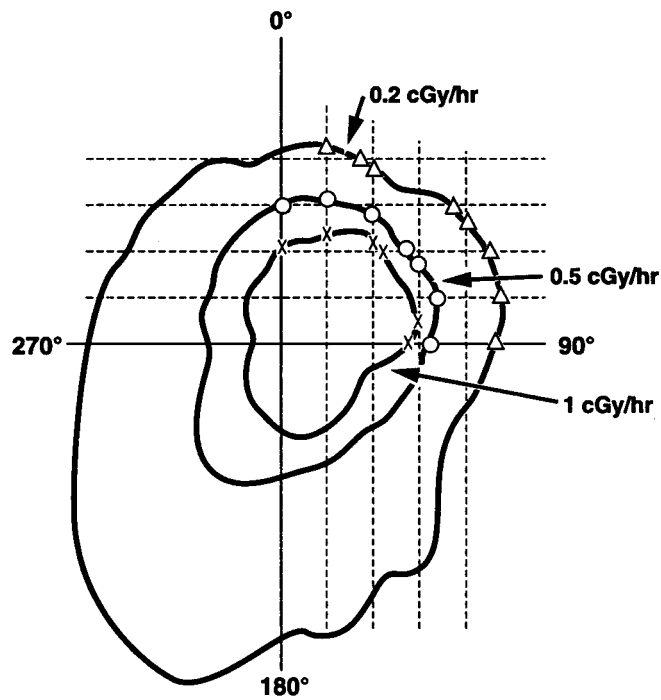


Figure A-III. Grid Plot

- g. The report of an area survey should include the following information: the name of survey team members, the date and time that the survey was performed, the type of radiation detection equipment used in the survey, and other remarks that may be helpful in evaluating the attached survey plot.
- h. While area surveys are generally considered as passive surveys, i.e., actions taken based on survey results may be deferred for hours or days, personnel surveys are active, in that actions taken to remove contaminated materials from body surfaces are usually taken immediately. Because they are active surveys, the locations of the contamination on body surfaces are not usually plotted as is the case in area surveys. Instead, contaminated areas are identified with tapes, dyes, magic markers, etc., on the body surface itself.
- i. In performing a personnel survey, the individual to be monitored stands, with legs spread and arms extended. The radiation monitor begins the survey at the head, subsequently surveying the upper trunk, arms, lower trunk and legs. The individual being surveyed is asked to do an about face, and the procedure is repeated. As in area surveys, care must be taken not to permit the detector probe to touch any potentially contaminated surfaces. When a contaminated area is identified, it is marked. If it is suspected that contamination may have entered a body opening or wound, swabs may be used to collect surface material. These swabs may then be checked with a radiation detector.
- j. Personnel survey records should indicate the name of the individual surveyed, the sites and levels of any activity detected, and the nature of any instructions given to the contaminated individual concerning decontamination procedures.
- k. Equipment/material surveys are performed in a manner similar to that used for area surveys. Hand sketches of the object to be surveyed are prepared. Surveying begins at the lower and outer surface of the object to be surveyed and progresses in an upward direction until the object is completely surveyed. Areas of contamination and levels of activity identified are noted on the sketch.
- l. Survey records developed from equipment/material monitoring are similar in their information content to those prepared for area surveys.



**NATO HANDBOOK ON THE MEDICAL ASPECTS  
OF NBC DEFENSIVE OPERATIONS  
AMedP-6(B)**

**PART I - NUCLEAR**

**ANNEX B**

**HAZARDS OF NUCLEAR WEAPONS ACCIDENTS**

**1 FEBRUARY 1996**

**TABLE OF CONTENTS**

	Page
<b>SECTION I - GENERAL</b>	
Paragraph B.01. Introduction	B-3
B.02. Accidental Detonations	B-3
B.03. Types of Radiation	B-3
B.04. Early Rescue and Evacuation of the Injured to Medical Facilities	B-4
<b>SECTION II - GENERAL HAZARDS</b>	
Paragraph B.05. Explosive and Fire Hazards	B-4
B.06. Contamination of the Injured with Hazardous Material	B-4
B.07. Contamination of Hospital Facilities, Equipment and Personnel	B-5
B.08. Contamination of Geographical Area Around Accident with Potential Hazard to Local Population	B-5
B.09. Decontamination Operations	B-5
<b>SECTION III - INTERNAL HAZARDS</b>	
Paragraph B.10. General	B-6
B.11. Radioactive Materials	B-6
B.12. Non-Radioactive Materials	B-8

**THIS PAGE INTENTIONALLY LEFT BLANK.**

## ANNEX B

## HAZARDS OF NUCLEAR WEAPONS ACCIDENTS

## SECTION I - GENERAL

**B.01. Introduction.**

Nuclear weapons accidents can be a peacetime and wartime problem, and all elements of a military medical service should be prepared to provide the medical support required if they occur. To accomplish this most effectively, all medical facilities should have specific procedural guides readily available, so that even personnel who have not been specifically trained in the hazards of nuclear weapons can perform necessary actions effectively and safely with minimal supervision. To help accomplish these objectives, detailed information is included in the several sections of Annexes B and C. The sections of this Annex include general information concerning accidents and their hazards. The three sections in Annex C include information specifically organized to facilitate the development of procedural guidelines for the various departments and services of a medical facility. In wartime, the rigorous peacetime responses to accidents may not be fully implemented.

**B.02. Accidental Detonations.**

- a. *High Explosive Detonations.* All nuclear weapons contain high explosive material. In any accident, there is a risk of either explosion of this material or fire. Either may occur immediately at the time of the accident or later if a weapon is severely damaged and fragments of high explosive and nuclear material are scattered. All personnel at an accident site must be aware of these hazards and conduct all operations and duties under the direction of experienced ordinance disposal personnel.
- b. *Nuclear Detonations.* This is not considered to be a credible event.

**B.03. Types of Radiation.**

- a. The principle fissionable materials in nuclear weapons ( $^{235}\text{U}$  and  $^{239}\text{Pu}$ ) are basically alpha particle emitters. However, there are several weak (up to 185 KeV) x and gamma ray emissions associated with alpha particle decay. The radiation intensity of x and gamma radiations at an accident site is generally low.
- b. The weak x and gamma radiations from unfissioned bomb material are not very penetrating. The intensity is reduced by approximately one half by 5 mm of tissue or water. The principal hazard is from airborne alpha particle emitters.

#### **B.04. Early Rescue and Evacuation of the Injured to Medical Facilities.**

- a. The victims of such accidents may have serious injuries, frequently multiple, requiring early, skilled treatment. These will include burns, fractures, head injuries, etc., typical of those sustained in serious accidents of all types.
- b. Significant radiation injury will not be present. Contamination of the injured with varying amounts of radioactive material may be present, but this contamination should not be a serious, immediate hazard to either the injured or to personnel caring for them.
- c. The number of accident victims may vary from very few to a large number depending on the circumstances of the accident. Immediate medical care should be obtained from the closest medical facility, either military or civilian.

### **SECTION II - GENERAL HAZARDS**

#### **B.05. Explosive and Fire Hazards.**

- a. As noted above, there is a significant risk of high explosive detonations and/or fire at a nuclear weapons accident site. This is increased in vehicular or aircraft accidents where oil or gasoline is present; and, as a result, burns would be a frequent and serious problem among the casualties of a nuclear weapons accident.
- b. If there is a fire, the smoke will contain a large variety of burned material from the weapons, the transport vehicle, and the environment. Some of these materials can be dangerous if inhaled. The particle sizes in the smoke from a fire will be important; a percentage of particles smaller than about 10 microns, if inhaled, may penetrate deeply into the respiratory system where the probability of retention is high. This can result in significant damage to the lungs. The respiratory hazard is discussed more fully in Section III.

#### **B.06. Contamination of the Injured with Hazardous Material.**

Contamination of injured personnel may be due to either radioactive or toxic materials. In general, the hazard to both the patient and attending medical personnel will be so negligible that

### **NECESSARY MEDICAL OR SURGICAL TREATMENT MUST NOT BE DELAYED BECAUSE OF POSSIBLE CONTAMINATION.**

Decontamination should be done as soon as possible during the care of such patients, and ideally, prior to admission to a hospital. However, this will not always be possible, and decontamination procedures should be part of the operational plans and guides of all divisions and departments of medical facilities, not just of emergency room or teams. This insures flexibility of response and action and will prevent delay in needed medical treatment. The simple removal of outer clothing and shoes will, in most instances, affect a 90-95% reduction in the patient's contamination.

**B.07. Contamination of Hospital Facilities, Equipment, and Personnel.**

- a. Since the treatment of injured, contaminated personnel may result in the contamination of almost any part of a medical facility, a large number of the medical personnel procedures must be able to set up to accomplish the following:
  - (1) Minimize the degree of contamination.
  - (2) Identify and measure the extent of contamination.
  - (3) Remove the contamination.
- b. The removal of contamination is a two-part problem and includes decontamination of personnel as well as decontamination of equipment and facilities. The former must be started as soon as possible, even if monitoring facilities are not available. Standardized procedures of decontaminating personnel must be established and instituted. Personnel must not be released before they have been monitored and decontaminated completely. The monitoring capability would be obtained from the technical teams working at the accident site. This requires coordination and communication with the authorities responsible for overall management of the nuclear accident.

**B.08. Contamination of Geographical Area Around Accident with Potential Hazard to Local Population.**

Medical personnel may be called upon to give advice as to the nature and degree of public hazard associated with a given type and level of contamination. This hazard will rarely be an acute one but may well be a significant long term one. The advice given will be an essential factor in determining what methods are used to minimize and remove the hazard.

- a. The most probable hazard will occur downwind from an accident site due to airborne particles of radioactive material which could be inhaled. Early after an accident, adequate information may not be available to determine the exact degree of the hazard from airborne contamination. As a result, a decision to evacuate an area close to an accident location may have to be made by local authorities without waiting for radiation measurements. No precise guidance can be given for these types of situations.
- b. A much less frequent hazard would be contamination of water supplies if an accident occurred near a river source or reservoir. Dilution and settling of insoluble materials would further reduce this small hazard, and simple monitoring measures by trained personnel could be obtained before condemning the water supply. Water from other locations can be used temporarily until adequate measurements are made to determine whether there has been contamination or not. However, drinking water contaminated by plutonium is an insignificant hazard.

**B.09. Decontamination Operations.**

Exposure level criteria used in accident related operations are basically the same as peacetime industrial exposure limits, as defined by the laws of the country in which the accident occurs or by international agreement (wartime exposure limits may be higher). Emergency

exposures exceeding specified limits must be restricted as much as possible to those truly critical operations such as rescue of the injured. Once the emergency phase of a nuclear accident is over, decontamination must be carried out under strictly controlled medical supervision. This is a separate operation from care of the injured and requires the presence of specially trained physicians and health physicists.

### SECTION III - INTERNAL HAZARDS

#### B.10. General.

- a. At the typical accident site, there will be no significant external radiation hazard. A significant internal hazard can be present both early and late. The inhalation hazard is more serious immediately after an accident and during a fire, or following an explosion of conventional explosives when the plume may contain a percentage of respirable particles.
- b. These particles settle to the ground but can be resuspended. They are diluted by dispersion. They may be inhaled if they are resuspended as dusts into the atmosphere by winds or movement of people and vehicles. The concentration of particles per unit volume of air under these circumstances will be much less than that in the smoke of the burning weapon, and the particle size distribution will be different.
- c. The actual substances which may be inhaled include a wide variety of both radioactive and nonradioactive materials.

#### B.11. Radioactive Materials.

- a. *Plutonium.* Plutonium (Pu) is a heavy metal (atomic number 94), which is artificially produced in reactions by bombardment of uranium 238 with neutrons. Most Pu so produced is  $^{239}\text{Pu}$ . However, relatively small quantities of other isotopes are also produced, and  $^{241}\text{Pu}$ ,  $^{242}\text{Pu}$ , and  $^{244}\text{Pu}$  will be present in small quantities in the plutonium used in weapons.

- (1) If plutonium particles are inhaled, they will be deposited at all levels of the respiratory system, depending on their size. The larger particles are deposited in the nasopharynx or high in the tracheobronchial tree. Only the very small particles, 10 microns in diameter or smaller, are deposited in the alveolar air sacs. The plutonium deposited in the terminal bronchioles above the alveolar air sacs will be cleared from the lungs by the action of the ciliated epitheliums making up the respiratory mucosa. These particles do not present any significant hazard. The possibility of any significant radiation damage while they are in transit out of the lungs or subsequently during their passage through the gastrointestinal system is almost nonexistent. Any cells which are damaged by radiation would be sloughed off and replaced during the normally high rate of cell turnover which occurs in these tissues.

- (2) The plutonium remaining in the alveoli can cause damage, since much of it will remain there essentially for the lifetime of the individual. The rate of

removal of plutonium deposited in the air sacs is difficult to estimate, but animal experimentation has indicated that it would take at least several years for significant amounts to be removed. Some of the plutonium particles are phagocytized and picked up by the lymphatic system, but they will not be transported far since a large proportion will be trapped in regional lymph nodes of the lung. Only very negligible quantities will reach the blood stream.

- (3) Radiation from plutonium and its daughter products trapped in the lung tissue can cause an inflammatory response and eventual fibrosis. The degree of fibrotic scarring will depend upon the amount of plutonium deposited and time. The overall reserve capacity of the lungs is so great, however, that this would only rarely become a serious problem. Carcinogenesis must also be considered the main hazard, but it is of small relevance in war. Most cells damaged by alpha radiation will be lethally damaged. A very small percentage will be non-lethally damaged. However, there is some x-ray and gamma radiation associated with plutonium and its impurities. The hazard of this radiation to an organ like the lungs is difficult to assess, but it is penetrating and must also be considered as a potential producer of both fibrosis and cancer. This x-ray or gamma radiation has a very low energy level (17 KeV and 60 KeV respectively) and is difficult to detect at low concentrations with standard x-ray sensitive instruments. Special probes are available as accessories to some alpha sensitive detection instruments and are of value in monitoring contamination by plutonium.

b. *Uranium.* Uranium (U) is also a heavy metal (atomic number 92) and an alpha emitter. On a gram for gram basis, the typical uranium alloy has only about 1/500 the radioactivity of an equivalent amount of <sup>239</sup>Pu. Therefore, the radiation hazard associated with uranium is much less than that associated with plutonium. Otherwise, the same factors governing deposition and retention in the pulmonary system apply to uranium. Uranium metal can cause chemical toxicity (heavy metal toxicity) at exposures of 0.1 mg/kg body weight. This is seen as damage to the cells of the lower portion of the proximal convoluted tubules of the kidney. There is usually a lag period of 6 hours to several days followed by chemical necrosis. Even after levels which cause necrosis, the kidneys show evidence of regeneration within 2 to 3 days, depending on the severity of the initial exposure. Both ethylenediaminetetraacetic acid (EDTA) and DTPA have been used to increase excretion in experimental animals.

c. *Tritium.*

- (1) Tritium is an isotope of hydrogen. There are two other isotopes, protium or normal hydrogen (<sup>1</sup>H) which has one proton in its nucleus and no neutrons, and deuterium (<sup>2</sup>H) which has one neutron in its nucleus in addition to the proton. Deuterium is not radioactive and occurs in small quantities naturally. Tritium (<sup>3</sup>T) is radioactive, emitting a low energy beta particle. It is extremely rare in nature and must be made artificially in reactors to meet the requirements for its scientific, industrial, and military uses. Tritium has a physical half life of 12.26 years. It can be readily absorbed into the body and



becomes diffusely distributed throughout the body water. It may be inhaled, ingested, or absorbed transcutaneously. If a large amount is incorporated into the body accidentally, there is a serious risk of whole body beta irradiation and acute radiation sickness as described in Chapter 6 in this handbook.

(2) If patients are seen with suspected tritium contamination, the best treatment is to shorten the turnover time of the body water with forced fluid intake and diuretics. This essentially "flushes out" the tritium and can materially reduce the exposure time and the total dose of radiation received. Fortunately, tritium would not be a hazard in the usual accident situation because it dissipates so rapidly. Generally, it will not accumulate in an outside area, although tritium contamination of metal or other surfaces can be persistent. It would be a hazard if an accident occurred in an enclosed space so that dispersion could not occur.

d. *Magnesium-thorium alloys.* Magnesium-thorium alloys should also be considered as radioactive hazards since radioactive thorium is an alpha emitter. Many aircraft and missile structures contain significant amounts of magnesium-thorium (up to 4% of thorium), therefore, in an accident the radioactive thorium must be recovered and disposed as radioactive waste.

## B.12. Non-Radioactive Materials.

In any modern weapon system, a fire involving the various components of airplanes, missiles, etc., will release a large variety of non-radioactive toxic materials into the atmosphere. Among these, beryllium is the most important because of the severity of the clinical effects which may be associated with any exposure to this quite hazardous material. This material is far more important than any others and is discussed first.

- a. *Beryllium.* Beryllium is a light, gray-white metal. It is not radioactive. However, it is one of the most toxic metals known. If beryllium in any form is inhaled, a particularly severe pneumonitis (berylliosis) may follow. The resulting pulmonary disability is progressive and frequently fatal, either within a few months or after a period of several years. There is no specific treatment. In addition, beryllium can be a hazard if it contaminates wounds. Such contamination results in a severe local inflammatory response and the development of persistent granulomatous lesions, requiring surgical excision. Since beryllium is not radioactive, its presence at an accident site cannot be detected readily with radiac instrumentation. It should be suspected if accident victims have any symptoms or signs of pneumonitis.
- b. *Lithium and Plastics.* Lithium, the lightest of all metals, is used extensively in the field of nuclear technology, often in the form of a hydride. If lithium hydride is exposed to water and carbon in the presence of a fire, a chemical reaction occurs which produces acetylene gas. This in turn increases the intensity of the fire. Also, a wide variety of plastics are used in modern military weapon systems. Many of these, if burned, produce toxic fumes.

**NATO HANDBOOK ON THE MEDICAL ASPECTS  
OF NBC DEFENSIVE OPERATIONS  
AMedP-6(B)**

**PART I - NUCLEAR**

**ANNEX C**

**GENERAL GUIDELINES FOR MEDICAL SUPPORT IN NUCLEAR ACCIDENTS**

**1 FEBRUARY 1996**

**TABLE OF CONTENTS**

	<b>Page</b>
<b>SECTION I - GENERAL</b>	
Paragraph C.01. Introduction	C-3
<b>SECTION II - GUIDELINES FOR MEDICAL ADVISORS</b>	
Paragraph C.02. General	C-3
C.03. Management of Contamination	C-4
C.04. Personnel Precautions	C-4
C.05. Protective Masks	C-4
C.06. Protective Clothing	C-5
C.07. Decontamination of Equipment	C-5
<b>SECTION III - GUIDELINES FOR MEDICAL FACILITIES</b>	
Paragraph C.08. Guidelines for Medical Personnel Involved in the Rescue and Evacuation of the Injured at a Nuclear Accident Site	C-6
C.09. Guidelines for Nursing Service and Emergency Room Involved in Initial Care, Resuscitation, and Admission of Contaminated Patients	C-7
C.10. Guidelines for Operating Rooms Involved in Care of Contaminated Patients	C-8

THIS PAGE HAS BEEN LEFT INTENTIONALLY BLANK

## ANNEX C

## GENERAL GUIDELINES FOR MEDICAL SUPPORT IN NUCLEAR ACCIDENTS

## SECTION I - GENERAL

## C.01. Introduction.

- a. The following guidelines will be of use to medical personnel required to plan the medical support a hospital facility would provide in case of a nuclear weapons accident. They could be used by either military or civilian facilities and can act as basic background information to aid in the development of specific procedural guides.
- b. Copies of the separate guidelines should be made available to hospitals in sufficient quantities so that they would be available to all personnel at the time of an accident. Thus, untrained personnel would have guidelines they could apply.

## SECTION II - GUIDELINES FOR MEDICAL ADVISORS

## C.02. General.

- a. Selected medical personnel should be given the responsibility of planning the medical support required for nuclear weapons accidents. They should maintain up-to-date plans and be prepared to train and supervise other medical personnel. They should have prepared procedural guides available for distribution to any medical facility which may become involved in the support of such accidents. They can act as medical advisors to such facilities and can facilitate greatly the early care of patients and subsequent decontamination of medical facilities if it is required.
- b. These medical advisors must also be prepared to deal with the question of how much hazard there is to the local population in the area of an accident. The hazard to be considered is the long term one to people living their entire lifetimes in the area. The guides to be used are the laws of the country or recommendations of the International Committee on Radiation Protection for protection of the population at large. These peacetime standards are very strict and would not be applied in war.
- c. The potential public health hazard is fairly minimal. Neither plutonium nor uranium is soluble as an oxide and neither is incorporated into the metabolic cycles of plants. As a result there is very little chance of these elements being ingested either by animals or humans. Even if ingested, their insolubility all but completely precludes any absorption from the gastrointestinal tract. The major hazard is inhalation of the material if it is suspended in the atmosphere. Retention of such materials in the lungs can result in tissue damage as noted above in Annex B, Paragraph B. 11. However, the amounts required to cause any real risk of significant pulmonary disease are very much greater than will normally be present, particularly once material from the accident is dispersed widely on the ground. Therefore, the

inhalation hazard to people living near an accident area is minimal except during times when extensive cleanup operations are going on and materials are being resuspended in the atmosphere.

- d. Monitoring of the degree of atmospheric resuspension of hazardous materials with specially designed air samplers must be carried out during such operations. If the areas of contamination and the subsequent cleanup operations are large, enough of these devices to give adequate geographical coverage is required. At times, around the clock monitoring may be essential.

### C.03. Management of Contamination.

There are several methods of dealing with radioactive contamination.

- a. The half life of  $^{239}\text{Pu}$  is  $2.43 \times 10^4$  years, and that of  $^{235}\text{U}$  is  $7.1 \times 10^8$  years so that waiting for decay is impractical (not an option).
- b. Resuspension of materials into the atmosphere would be the most serious hazard and extensive monitoring would be required. Wetting down the area with airborne water tankers might be required.
- c. If the levels of activity allow cleanup operations to proceed, terrain may have to be removed and buried in sealed containers. The levels to which decontamination is carried out, or the levels at which other activities such as evacuation are initiated, are laid down by individual countries for peacetime use.

### C.04. Personnel Precautions.

When it is necessary to work in an environment containing significant concentrations of hazardous materials, control measures must be instituted to limit individual exposures. These measures may range from limitations on the length of time that personnel may stay in an environment to the provision of respirators and protective clothing. In certain circumstances, self-contained air supply systems may be needed. Two primary requirements must be met by any protective equipment. First, it must protect, i.e., its use should ensure safety of the using personnel; and second, the equipment must be reasonably comfortable, or it will not be used. An example of this latter problem is frequently seen in the use of protective masks or respirators, where the quality of the seal of the mask to the face determines the effectiveness of the protection. It has been found that many half-face masks, in particular, can be effectively sealed only by tightening the straps to the point of pain. As a result, users of these masks often do not tighten the straps sufficiently to obtain a seal, and therefore, are less well protected.

### C.05. Protective Masks.

Protective masks may be classified in several different ways. Some of these are by their principle of operation such as filtration, by the type of face piece, half-face or full-face, and by the degree of protection. The most convenient classification is by method of operation into two broad groups: Air Supplying and Filtration Type.

- a. *Air Supplying Masks.* Air supplying masks are made up of a face piece and an air

source and the necessary tubing and valves for connecting the two. A mask of this type is essential for work in spaces which are deficient in oxygen and is the only effective protection against the gaseous form of hydrogen or its isotopes. The face piece of such a breathing apparatus should be of the full-face type. The tanks should have an air supply of at least 30 minutes under conditions of normal exertion and should have both visible gauges indicating the pressure and some type of an alarm system to warn the user when expiration of the air supply is imminent.

- b. *Filtration Type Masks.* Filtration type masks are relatively simple and compact since they are not dependent upon a separate air supply. There is no limitation, essentially, to the length of time they can be worn. The life time of the canister or filter system is the limiting factor. The deficiency of these masks is that they have a tendency to leak unless they are properly fitted to the face. They generally come in two forms: the half-face or the full-face form. The typical military full-face masks are generally quite efficient and afford good protection against particulate contamination. It is essential, however, that the masks chosen fit the user comfortably and without leaking. It is recommended that, where practicable, such masks be tested in a special chamber containing an irritant smoke or other suitable agent.

#### **C.06. Protective Clothing.**

- a. The purpose of protective clothing is to keep contaminating material away from the skin of the individual and to assist with decontamination.
- b. In common practice, the protective clothing requirements are not strictly met and most protective clothing is only partially protective. For instance, protective clothing is readily penetrated by tritium.
  - (1) Coveralls made of closely woven materials are generally used. Two pair of such coveralls are usually worn, along with cotton or rubber gloves, rubber boots, and protective caps or hoods. All openings, such as where the gloves overlap the sleeves, are sealed, usually with adhesive masking tape. It has been found that untreated cotton fabric is a reasonably effective barrier to dust and that it is easily decontaminated by normal laundering procedures. Furthermore, water vapor can penetrate the fabric, thus enabling normal body cooling mechanisms to function.
  - (2) The clothing must be worn with an efficient full-face mask in order to achieve reasonable protection against particulate aerosols with a high percentage of very small particles. Finally, clothing worn for protection against particulate contamination will become contaminated itself and must be removed as an individual leaves a contaminated area. The way in which the clothing is removed must be carefully supervised so personnel do not contaminate themselves during the procedure.

#### **C.07. Decontamination of Equipment.**

In most cases of contamination of equipment and buildings, the material will be removed by a mixture of normal house cleaning methods. Vacuum cleaners which can handle wet material

and have high efficiency filters are particularly useful. Some surfaces may require repeating scrubbing and vacuuming before they are free of contamination. Obviously, these procedures must be carried out or supervised by specially trained personnel.

### SECTION III - GUIDELINES FOR MEDICAL FACILITIES

#### **C.08. Guidelines for Medical Personnel Involved in the Rescue and Evacuation of the Injured at a Nuclear Accident Site.**

- a. When an accident involving a nuclear weapon occurs, there is a definite probability that a number of casualties will result. The number should be small, but the injuries may be severe and multiple, much like those sustained in serious vehicle accidents. *Emergency personnel sent to an accident site must be well trained in first aid of trauma.* By the time medical personnel arrive at the scene, initial rescue may have been effected and some first aid given. The medical personnel should assist in further rescue operations and begin evacuation to the *closest medical facility* as soon as possible. They should notify the receiving facility of the nature of the accident and the number and type of patients involved.
- b. The radiation given off by plutonium or uranium is short range alpha and is not a hazard to attending personnel unless the actual radioactive material itself is inhaled. Nonmedical personnel already on the scene may direct medical personnel to wear protective masks. These directions should be complied with because there may be an inhalation hazard at the accident site. Standard military protective masks are excellent protection. They should be worn by personnel inside ambulances until the patients are brought to the medical facility. Hospital personnel can wear a standard surgical mask with safety.
- c. After the patients have been brought to a medical facility and turned over to hospital personnel for further care, ambulance personnel and the ambulances should be decontaminated. Decontamination of personnel should be started as soon as possible, even if monitoring facilities are not available. These personnel must not be released, however, until monitoring is possible and indicates that they are no longer contaminated. This requires special alpha sensitive radiation equipment, *not* generally available at hospitals. This equipment must be obtained from teams at the accident site.
  - (1) The place for decontamination of ambulance personnel can be the same place used by other hospital personnel such as the Emergency Room Staff, ideally away from the Emergency Room.
  - (2) The place should have two entrances and a shower. There should be a number of laundry bags setup and tagged. The personnel should strip off all clothing, putting them in appropriate bags. If necessary, large tags should be attached to the clothing. Personal items, such as watches and jewelry, should be put in plastic bags. Their protective masks should also be put in a special bag.
  - (3) A complete set of clean clothing should be made available. If this is not possible, clean scrub suits should be provided personnel until such time as clean clothing can be obtained. Complete monitoring is essential after showering.



**C.09. Guidelines for Nursing Service and Emergency Room Involved in Initial Care, Resuscitation, and Admission of Contaminated Patients.**

- a. Basically, any medical facility must have a plan for the handling of patients which does not change fundamentally the operation of the facility or techniques of patient care. This is best accomplished by restricting changes in basic operations to those which are absolutely essential. The most important objective is to give injured patients proper, efficient, and rapid care without spreading contamination. Restriction of contamination is best accomplished by restricting and controlling traffic in the facility.
- b. A traffic diagram to be used in case contaminated patients must be handled should be developed by each medical facility and should be posted in the emergency room area.
- c. If there is a choice of rooms in which patients can be treated, contaminated patients should be treated in that room to which they can be brought without crossing main thoroughfares in the building.
- d. If the hospital has been warned of possible contamination, the route over which the patients are to be brought may be covered with paper. After the patients are in the treatment room, this paper should be carefully rolled up by personnel wearing caps, gowns, masks, and gloves. The paper then should be put in tagged bags. The process can be repeated as often as necessary. If patients are brought in over uncovered floors, immediately cover the floors with paper and leave in place until personnel with the proper monitoring equipment arrive to help evaluate the hazard. Traffic over the paper must be limited to that which is absolutely essential.
- e. There should be several laundry hampers in the treatment rooms and in the adjacent hallways which are tagged so that all linens and clothing can be properly identified for later decontamination.
- f. *A treatment team should be organized to function much as do operating room teams.* This system requires a moderate amount of prior planning and training so that it will function smoothly and effectively.
  - (1) All members of this team should wear caps, gowns, masks, and gloves.
  - (2) The physician and the assistant, if required, would be restricted to the area immediately around the patient.
  - (3) Circulating personnel in the room would bring supplies to the physician but would not touch the patient or the equipment being used by the treatment team. *These personnel would not leave the room.*
  - (4) There should be other circulating personnel who would bring supplies to the room but who would not enter the room.
- g. The treatment priorities of a contaminated patient will vary with the seriousness and nature of the basic injuries. While life saving resuscitative measures are progressing, certain decontamination procedures can be carried out without compromising the basic care of the patient.
  - (1) The patient's clothing should be removed carefully and put into a tagged bag for later decontamination or disposal. Valuables should be put into a tagged bag (preferably plastic) and held in a specially designated place for

- monitoring and decontamination. They should not be mixed with the valuables of other patients.
- (2) The patients must be thoroughly washed off, especially exposed surfaces. The rinse water must be collected. Disposal later must be done in accordance with the limitations of the laws of the country in which the accident occurred. Consultation with expert personnel from among those at the accident site will be necessary to assure that this is done properly.
- h. *Normal surgical management of wounds will be more than adequate for removal of radioactive contamination and special procedures are not required.* Again, the rinse water or sponges should not be disposed of until expert consultations have been obtained. Material objects from the wounds must be saved and if separable from the rest of the waste, put in specially marked bags. These fragments will be studied by technical experts and require special disposal.
  - i. Patients should be admitted to specially designated wards or rooms and kept in semi-isolation to prevent or limit spread of contamination.
    - (1) All personnel should put on gowns and gloves, caps and masks, and shoe covers to enter room and remove them after each visit.
    - (2) All waste materials and linens must be marked and monitored.
  - j. Frequent monitoring by trained health physics personnel will be required to determine when it is proper to discontinue isolation techniques.
  - k. If the patient urinates, the urine should be saved for analysis for radiological contamination. Normal urinalyses can be done on portions of the sample with safety, but the laboratory should be notified that there is a potential contamination with radioactive material. It is essential that a record be kept by the laboratory of the volumes of urine so that later calculations can be made of estimated body burdens of radioactive materials by appropriate laboratories. Fecal samples should also be taken and retained in addition to nose blows and swabs.

#### **C.10. Guidelines for Operating Rooms Involved in Care of Contaminated Patients.**

- a. Among the patients from a nuclear accident, there will probably be a number who are severely enough injured to require extensive surgical care. These patients may be contaminated with any of a variety of materials, both radioactive and nonradioactive. Most of these materials will not constitute a significant hazard to operating room personnel, providing certain fairly simple precautions are taken. The basic organization and routine of the operating room should not be changed. However, in order to minimize and restrict contamination, certain additional precautions should be taken.
- b. Since the hazard from any contaminating material will be respiratory, all personnel in the operating room area should wear masks in place at all times when potentially contaminated patients are being cared for. When monitoring personnel and equipment are available, they will be able to advise the operating staff when it is safe to unmask. The staff should not unmask until so advised.
- c. It would be preferable to restrict the use of operating rooms so as to limit potential contamination. However, this may not be possible if there is a significant number

of accident victims requiring surgery. Once an operating room has been used for the surgical care of nuclear accident patients, monitoring and decontamination will be necessary before it can be used for normal surgical cases. Therefore, the Surgical Service must be prepared to lose the use of the rooms involved for the period of time necessary to accomplish these procedures. In some instances, it may be practical for a hospital to set up a temporary operating room close to, but not in, the regular operating room area. In other instances this will not be possible.

- d. The actual surgery can be managed according to Standard Operating Procedures for handling cases contaminated with infectious hazards with the following additions or exceptions.
- (1) All waste material will be saved in suitable containers. Large plastic bags are the most suitable since they do not leak if properly handled. These must be tagged so that they can be identified later and examined by qualified personnel from among the technical teams responsible for salvage and disposal at a nuclear accident.
  - (2) When personnel remove their surgical gowns, caps, and gloves, they must be considered as contaminated also. They must be removed carefully and the people assisting in their removal must be capped, gowned, and wearing gloves. The masks should be put in a specially marked container.
  - (3) All personnel must shower completely after working on such cases and must not be released from the area until after monitoring. This monitoring is essential and must be done by qualified personnel with special equipment. These personnel will come from the technical teams working at the accident site.

## REFERENCES

## Standard Textbooks

- Alper, T. *Cellular Radiobiology*. Cambridge University Press, Cambridge, 1979.
- Alter, W. A., and Conklin, J. J. "Radiation Casualties" in: *Handbook of Disaster Medicine*. Medical Examination Publishing Co., 1983.
- Berdjjs, C. C. *Pathology of Radiation*. Williams and Wilkins, 1971.
- Biological Effects of Ionizing Radiations*. National Academy Press, Washington, DC, 1980.
- Bond, V. P., and Sugahara (eds.). *Comparative Cellular and Species Radiosensitivity*. Igaku Shoin, Tokyo, 1969.
- Broerse, J., and MacVittie, T. *Response of Different Species to Total Body Irradiation*. Martinus Nihoff Publisher, 1984.
- Chadwick, K. H., and Leenhouts, H. P. *The Molecular Theory of Radiation Biology*. Springer-Verlag, Berlin, 1981.
- Conklin, J. J., Walker, R. L., and Hirsch, E. F. "Current Concepts in the Management of Radiation Injuries and Associated Trauma" in *Surg. Gyn. Obst.* 156:809-829, 1983.
- Elkind, M. M., and Whitmore, G. F. *The Radiobiology of Cultured Mammalian Cells*. Gordon and Breach Science Publishers, New York, 1967.
- Fabrikant, J. I. *Radiobiology*. Year Book Medical Publishers, Inc., Chicago, 1972.
- Glasstone, S., and Dolan, P. J. *The Effects of Nuclear Weapons*. U.S. Department of Defense/U.S. Department of Energy, 3rd Edition, 1977.
- Hall, E. *Radiobiology for the Radiologist, 2nd edition*. Harper and Row Publishers, Inc., Hagerstown, Maryland, 1978.
- Hubner, U. F., and Fry, S. A. (Eds.). *The Medical Basis for Radiation Accident Preparedness*. Elsevier North Holland, Inc., 1980.
- Langham, W. H. *Radiobiological Factors in Manned Space Flight*. National Academy of Sciences - National Research Council, Washington, DC, 1967.
- Lapp, R. E. and Andrews, H. L. *Nuclear Radiation Physics*, 4th Edition. Prentice-Hall, Inc., New Jersey, USA, 1972.

Messerschmidt, O. *Medical Procedures in a Nuclear Disaster*. Thiemig-Taschenbucher, Munchen, 1979.

Okada, S. *Radiation Biochemistry, Cells, Vol. 1*. Academic Press, New York, 1970.

*Radiological Health Handbook*. U.S. Department of Health, Education, and Welfare, Revised Edition, 1970.

Rubin, P. and Casarett, G. W. *Clinical Radiation Pathology, Vols. I and II*. W.B. Saunders Company, Philadelphia, London, and Toronto, 1968.

Travis, E. L. *Primer of Medical Radiobiology*. Year Book Medical Publishers, Inc., Chicago, 1975.

Walker, R. I., Gruber, D. F., MacVittie, T. J. and Conklin, J. J. (Eds.). *The Pathophysiology of Combined Injury and Trauma*. University Park Press, Baltimore, 1985.

### Official United States Publications

Department of the Army Field Manual 3-3. *Chemical and Biological Contamination Avoidance*. November 1992.

Department of the Army Field Manual 3-4. *NBC Protection*. May 1992.

Department of the Army Field Manual 8-10-7. *Health Service Support in a Nuclear, Biological, and Chemical Environment*. April 1993.

Department of the Army Field Manual 101-31-1. *Staff Officers' Field Manual: Nuclear Weapons Employment Doctrine and Procedures*. January 1986.

### NATO Documents

AMedP-7; STANAG 2873. *Medical Support Operations in an NBC Environment*.

STANAG 2083. *Radiological Hazards*.

STANAG 2866. *Medical Effects of Ionizing Radiation on Personnel*.

## GLOSSARY

A <sub>0</sub>	original activity
amu	atomic mass unit
atm	atmospheres of pressure
Bq	becquerel
CBF	cerebral blood flow
cGy	centiGray
Ci	curie
cm	centimeter(s)
co	cobalt
DNA	deoxyribonucleic acid
DTPA	diethylenetriamine pentaacetic acid (pentetic acid)
EBq	exabecquerel (10 <sup>18</sup> Bq)
EDTA	ethylenediaminetetraacetic acid (edetetic acid)
EMP	electro-magnetic pulse
ER	enhanced radiation
ETI	early transient incapacitation
ETI-PD	early transient incapacitation and performance decrement
Ev	electron volt
Gy	gray
HOB	height-of-burst
HVL	half-value layer
KBq	thousand Becquerels
KeV	thousand electron volts
Km	kilometer(s)
kPa	kiloPascals
Kt	kiloton(s)
Kvp	kilovolts (peak)
LD	lethal dose
LET	linear energy transfer
m	meter(s)
MeV	million electron volts
mm	millimeter(s)
mm <sup>3</sup>	cubic millimeters
Mt	megaton
Na	sodium
NATO	North Atlantic Treaty Organization
PBq	pets-becquerel (10 <sup>15</sup> Bq)
PD	performance decrement
Pu	plutonium
rad	radiation absorbed dose
RBE	relative biological effectiveness
REM	roentgen equivalent, man

RPL	radiophotoluminescent
SD	skin dose
sec	second(s)
SI	systems international
Sv	sievert (SI unit of radioactive dose equivalent)
TLD	thermoluminescent dosimeter
TNT	trinitrotoluene
U	uranium
Z/A	ratio of atomic number to atomic mass
μ	micro (10 <sup>-6</sup> )
μCi	micro Curie

## INDEX

	Paragraph
absorption	216-217, 221, 311-312, 316,318,407, 528-529, C.03
agents	524, 529, 622-623
air embolism	403
air burst	626, 706
alpha particle	215, 218-219, 319, 504-506, A.03, A.04, B.03
anemia	515, 614
anorexia	617
antiemetics	619
atomic volume	224
atomic structure	504
atomic	102, 201, 204-208, 216-218, 220, 222-224, 319, 504, B.11
atomic mass	206-208, 220, 222-223
atomic mass unit	207
beta particle	215-220, 506, A.03, A.04, B.11
Becquerel	214
binding energy	203, 207, 217
biochemical	501
biological effects	301, 401, 501, 503, 513
blast injury	403-404
blast wave	302-310, 312, 316, 402-403, 602
blast winds	307,414
blindness	412, F.4-I
burn	303-304, 311, 316, 407-412, 505, 605-611, 617, 620, 623, 706-707, 717, B.04, B.05, B.12
carcinogenesis	523-524, B.11
casualties	102, 402-404, 501, 504, 602, 605, 612, 617, 619-620, 622,701, 706-709, 710, 712-713, A.05, B.05, C.08
chain reaction	209-210
chemical symbol	208
chromosomes	508, 511, 522
collisions	222-224, 312, 504, A.03
colloidal	610
Compton scattering	217
conservation of mass	207
contamination	320, 526, 528, 618, 712, 714, 716-718, A.01, A.05, B.04-B.08, B.11-B.12, C.02-C.03, C.05-C.07, C.09-C.10
convalescent	604
critical chain reaction	210
critical mass	210
curie	214
cytolysis	508
decontamination	618
delayed effects	523, 701
denudation	518
deoxyribonucleic acid	511
diagnosis	102, 603, 606, 609, 615, 617, 620, 624
differentiation	509, 513, 517, 609, 615, 617, 620, 624, 628
disintegration	214
dosimetry	617, 624, A.01, A.04



	Paragraph
drag loading	309
dynamic pressures	307
dysfunction	617, 619
early transient incapacitation	504, 520, 622
electromagnetic pulse	701
electromagnetic radiation	215-216, 222, 224, 303, 311-312, A.03
electron volt	217, 219, 222
element	205-206, 208-209, 213, 215, 223-224, 308, 504, 521, 528, 621, 630, 701, 703-705, 711-712, 717, B.01
Elkind repair	522
enhanced radiation	210, 222, 302, 706
enriched	210
erythrocytes	509, 514-515, 614
erythropoietic	514-516, 520
exabecquerel	214
excitation	216, 218-219, 223-224, 504, 507, A.03, A.04
explosives	203, 210, B.10
eyes	304, 311, 412, 525, 608
fallout	302-304, 319-320, 503, 519, 522, 526-528, 612, 617, 623-624, 706, 709-710, 712, 714-717, A.01, A.05
field expedient	716
fireball	303-307, 311-314, 320, 408, 412
fission	504, 519, 528, 706, B.03
fixed nonreplicating cells	509
fluorine	207
fusion	204, 211, 222, 305, 312, 318, 504, 622
gamma	215, 217-219, 221-222, 224-225, 302, 318-319, 502-506, 520, 624, 715, 717, A.03, A.04, B.03, B.11
gastrointestinal	403, 508, 513, 517-518, 522, 528, 612-613, 615, 617 619, 622, B.11, C.02
ground zero	225, 304, 306-207, 310, 315-316, 319, 706
gun	210, 703
half-life	213-214, 319, 529, 603, 610, 715, B.11, C.03, C.05
half-value	221
height-of-burst	225, 306-307
hematopoietic tissue	509
hemorrhage	403, 515, 517-518, 603, 614-615, 617, 622
hydrodynamic front	305
hydroxyl	223
hygiene	526, 717
hyperthermia	617
hypotension	616-617, 619
inelastic collisions	222, 224, 312, A.03
infrared	303
ingestion	320, 528, 618, 717
inhalation	320, 528, 608, 618, 717, B.10, C.02, C.08
ion pair	213, 216, 218-219, 223, A.03
ionizing radiation	213, 215-216, 219-220, 222, 302, 304, 317, 319, 501-502, 504, 508, 515, 520, 522, 524-525, 616, 706, 709, A.03, A.04

	Paragraph
isotopes	206, 208-209, 213, 215, 303, 317, 319-320, 527-529, 618, B.11, C.05
Karyolysis	508
Karyorrhexis	508
kiloton	210, 225, 302, 319, 409
kinetic energy	215, 217-218, 303, 312, 405, 407
latent	508, 516, 524, 613, 615-616
lawrencium	205
leukopenia	622
Linear Energy Transfer	219
lymphocyte	509, 514, 614, 617
Mach region	306
macrophage	522
manifest	307, 515-516, 612-613, 616
mass	203-210, 214-215, 217, 219-220, 222-223, 303, 403 405, 407, 504, 506, 513, 522, 617, 622, 625
mass defect	207
megacurie	214
microbial	611, 619, 621
missile injury	405
mitosis	508, 511, 515
moderators	210, 223
morphological	509, 514, 518
mutation	215, 511-512, 521, 523-524
myelopoietic	514, 516
neutron capture	319
neutron	205-210, 215, 219, 221-225, 302-304, 318-320, 502 504, 520, 522, 525, 618, 624, A.04, B.11
neutron-to-gamma ratio	225
neutrophil	516
nuclear detonation	102, 201, 204, 214, 301, 303, 305, 402, 405, 407, 412, 503 522, 616, 620, 706, 712, 715, 717, B.02
nuclear winter 626	
nuclear	101-102, 201, 204, 206, 208-213, 215, 217, 222-223, 225, 302-307 311, 313, 315-320, 401-402, 405, 407, 412, 501-504, 504-504, 508-508, 511, 517, 520, 526, 529, 601-605, 609, 612, 616, 620, 625-627, 701-712, 717, A.01, B.01-B.03, B.05, B.07, B.09, B.12, C.01, C.02, C.08, C.10
nucleus	205-211, 215-218, 223-224, 504, 508, B.11
nuclides	208, 213, 216
orders of magnitude	204, 717
overpressure	308
pair production	217
particulate	215, 222, 317, A.03, C.05, C.06
penetrating power	221, 506
performance decrement	520, 622
photoelectric effect	217
platelet	514-515, 517, 617
plutonium	209-210, 319, 528, B.08, B.11
prodromal	520, 613, 620, 623
protection factor	225

	Paragraph
proton	205-209, 215, 223, A.04, B.11
protoplasmic coagulation	508
pyknosis	508
radiation sickness	617
radioactive decay	213, 216
radioactivity	213-214, 528-529, B.11
radiochemical	507
radiodermatitis	523, 526
radioisotope	213-215, 303, 317, 320, 529, 618
radionuclides	213
radiosensitivity	509-510, 521
reaction	203-204, 209-210, 212, 222-224, 312, 318-319, 520 628-629, B.11, B.12
recovery	412, 513, 515-517, 520-522, 604, 612-614, 629-630
red cell	514-515
reflectors	210
regenerative	515, 517
Relative Biological Effectiveness	219, 504, 520
reproductive cell kinetics	521
residual radiation	302, 317, 319, 706, 712, 715
resuscitative	408, 604, 607, 610, C.09
retaliatory	701
retinal burn	412
rule of nines	607
semilogarithmic	213
shock wave	305-306, 310
spectrum	215, 217, 221, 302-303, 311, 313, 412, 504, A.04
spermatogonia	509, 521
stability	202-203, 205-206, 213
standard notation	208
staphylococcus aureas	621
static overpressure	307, 309, 403
subcritical chain reaction	210
supercritical chain reaction	210
surgical	604, 608, 618, 623, 717, B.06, B.12, C.08-C.10
Systems International	214
tampers	210
thermal radiation	210, 302-304, 311-316, 401, 407-409
thermonuclear device	320
thrombopoietic	514, 517, 522
TNT	203
transcutaneous	528, B.11
transmutation	215
trauma	524, 613, 617, 620, 623-624, A.05, C.08
ultraviolet	311
uranium	208-210, 212, 215, 319, B.11, C.01, C.08
vacuum	207, 307, C.07
vaporize	303, 312, 320
vegetative cells	509

	Paragraph
white cell	514
x-ray	210, 215-217, 219, 224, 302-304, 504, B.11, B.12
yield	210, 225, 302-307, 310-311, 315-320, 404, 405-412, 520, 706

**NATO HANDBOOK ON THE MEDICAL ASPECTS  
OF NBC DEFENSIVE OPERATIONS  
AMedP-6(B)**

**PART II - BIOLOGICAL**

**1 FEBRUARY 1996**

TABLE OF CONTENTS

	Page
CHAPTER 1 INTRODUCTION	
SECTION I - DEFINITIONS	
Paragraph 101. Purpose	1-1
SECTION II - HISTORICAL	
Paragraph 102. Historical Perspective	1-1
SECTION III - FACTORS INFLUENCING USE OF BIOLOGICAL AGENTS	
Paragraph 103. Scope of the Problem	1-2
104. Characteristics of Biological Agents	1-2
105. Classification	1-3
106. Dissemination	1-4
CHAPTER 2 RECOGNITION	
SECTION I - INTRODUCTION	
Paragraph 201. Overview	2-1
SECTION II - EPIDEMIOLOGY	
Paragraph 202. Difficulties in Detection	2-1
203. Attack Indicators	2-2
204. Additional Attack Indicators	2-2
SECTION III - SAMPLE COLLECTION	
Paragraph 205. Diagnosis	2-3
206. Environmental Sampling	2-3
207. Sampling Principles	2-3
SECTION IV - IDENTIFICATION OF SPECIFIC BW AGENTS	
Paragraph 208. Identification Methods	2-5
SECTION V - PSYCHOLOGICAL EFFECTS	
Paragraph 209. Psychological Impact	2-5
210. Effect on Individuals	2-5
211. Psychological Operations	2-5
212. Countermeasures	2-5
CHAPTER 3 DEFENSE	
SECTION I - INTRODUCTION	
Paragraph 301. General	3-1
302. Sanitation	3-1
303. Food and Water Sanitation	3-1
SECTION II - WARNING AND DETECTION	
Paragraph 304. Detection	3-1
SECTION III - PROTECTIVE EQUIPMENT	
Paragraph 305. Individual Protection	3-2
306. Collective Protection	3-2

	Page
SECTION IV - IMMUNOPROPHYLAXIS AND CHEMOPROPHYLAXIS	
Paragraph 307. Immunoprophylaxis	3-2
308. Chemoprophylaxis	3-3
CHAPTER 4 MANAGEMENT	
SECTION I - INTRODUCTION	
Paragraph 401. Management Approach	4-1
SECTION II - CASUALTY DECONTAMINATION	
Paragraph 402. Decontamination of Exposed Personnel	4-1
SECTION III - TREATMENT	
Paragraph 403. Principles of Treatment	4-1
SECTION IV - PROTECTION OF HEALTH CARE PERSONNEL	
Paragraph 404. Use of Barrier Techniques	4-2
405. Potential Biological Hazards	4-2
SECTION V - HANDLING OF CONTAMINATED REMAINS	
Paragraph 406. General Considerations	4-3
407. Risk Avoidance Procedures	4-3
SECTION VI - MASS CASUALTY MANAGEMENT	
Paragraph 408. Basic Care Provisions	4-3
409. Facilities	4-4
410. Equipment	4-4
411. Level of Care	4-4
412. Staggered Effect of Biological Agents	4-4
413. Effective Duty Period	4-4
414. Employment of Physicians	4-4
415. Psychological Considerations	4-5
ANNEX	
A MEDICAL CLASSIFICATION OF POTENTIAL BIOLOGICAL WARFARE AGENTS	A-1
B CLINICAL DATA SHEETS FOR SELECTED BIOLOGICAL AGENTS	B-1
C POTENTIAL BIOLOGICAL AENTS OPERATIONAL DATA CHARTS	C-1
D PATIENT MANAGEMENT CHARTS	D-1
REFERENCES	References-1
GLOSSARY	Glossary-1
INDEX	Index-1

List of Figures

		Page
Figure 1-I.	Droplet Size and Penetration of Respiratory Passages	1-5
D-I.	Model for an Approach to the Acutely Ill Febrile Patient (Example from the Middle East) (1 of 6)	D-4
	Model for an Approach to the Acutely Ill Febrile Patient (Example from the Middle East) (2 of 6)	D-5
	Model for an Approach to the Acutely Ill Febrile Patient (Example from the Middle East) (3 of 6)	D-6
	Model for an Approach to the Acutely Ill Febrile Patient (Example from the Middle East) (4 of 6)	D-7
	Model for an Approach to the Acutely Ill Febrile Patient (Example from the Middle East) (5 of 6)	D-8
	Model for an Approach to the Acutely Ill Febrile Patient (Example from the Middle East) (6 of 6)	D-9



**List Of Tables**

		Page
Table A-I.	Potential Biological Agents	A-3
C-I.	Bacteria	C-3
C-II.	Rickettsiae	C-4
C-III.	Chlamydia	C-5
C-IV.	Viruses	C-6
C-V.	Toxins	C-7
D-I.	Differentiation Among Botulinum, Nerve Agent, and Atropine Intoxications	D-3
D-II.	An Approach to Potential BW Agents By Predominant Clinical Finding or Syndrome	D-10

## CHAPTER 1

## INTRODUCTION

## SECTION I - DEFINITIONS

**101. Purpose.**

The purpose of this handbook is to provide an overview of potential biological warfare agents directed against human beings, problems that might be created during an attack in which a biological agent is utilized, and the current methods available to medical personnel for recognizing, preventing, and managing these problems. The following definitions will be used throughout this manual and are as stated in the NATO Military Agency for Standardization publication on agreed terms, AAP6:

- a. *Biological Agent (BA)*. The NATO definition of a biological agent is: a microorganism (or a toxin derived from it) which causes disease in man, plants or animals or which causes the deterioration of material.
- b. *Biological Defense (BD)*. Biological defense comprises the methods, plans and procedures involved in establishing and executing defensive measures against biological attack. (Procedures, equipment and training would be encompassed in this definition.)
- c. *Biological Warfare (BW)*. Biological warfare is the employment of biological agents to produce casualties in man or animals and damage to plants or material. The NATO definition then continues, to include, "or defence against such employment."
- d. *Biological Weapon*. A biological weapon is an item of material which projects, disperses, or disseminates a biological agent; including arthropod vectors.
- e. *Toxin*. A poisonous substance produced or derived from living plants, animals, or microorganisms; some toxins may also be produced or altered by chemical means. Compared with microorganisms, toxins have a relatively simple biochemical composition and are not able to reproduce themselves. In many aspects, they are comparable to chemical agents.

## SECTION II - HISTORICAL

**102. Historical Perspective.**

Throughout history, infectious diseases contracted naturally have had a significant impact on military operations. The intentional dissemination of disease adds a new dimension to threats that are posed by infectious and toxic agents traditionally transmitted only by natural routes. Biological agents reportedly have been employed to a limited extent during recent military conflicts (for example, dispersion of plague bacilli during World War II and use of trichothecene mycotoxins ("yellow rain" in South East Asia); however, their use actually dates from antiquity.

**SECTION III - FACTORS INFLUENCING USE OF BIOLOGICAL AGENTS****103. Scope of the Problem.**

- a. Biological weapons are unique in their ability to inflict large numbers of casualties over a wide area with minimal logistics requirements and by means which can be virtually untraceable. The ease and low cost of producing an agent, the difficulty in detecting its presence and protecting (and treating) its intended victims, and the potential to selectively target humans, animals, or plants conspire to make defense against this class of weapon particularly difficult.
- b. The nations of NATO remain highly vulnerable to the strategic, tactical, and terrorist use of biological weapons. As the military and economic gaps between nations grow and as some less advantaged nations seek a balance of power, there may be a tendency by these nations to overcome their disadvantage by choosing weapons of mass destruction that can be produced easily and cheaply. The purely financial advantage of employing biological weapons was clearly illustrated by a 1969 expert United Nations panel which estimated the cost of operations against civilian populations at \$1/Km<sup>2</sup> for biological weapons, versus \$600/Km<sup>2</sup> for chemical, \$800/Km<sup>2</sup> for nuclear, and \$2,000/Km<sup>2</sup> for conventional armaments.

**104. Characteristics of Biological Agents.**

- a. *Characteristics.* Intrinsic features of biological agents which influence their potential for use as weapons include: infectivity; virulence; toxicity; pathogenicity; incubation period; transmissibility; lethality; and stability. Unique to many of these agents, and distinctive from their chemical counterparts, is the ability to multiply in the body over time and actually increase their effect.
- b. *Infectivity.* The infectivity of an agent reflects the relative ease with which microorganisms establish themselves in a host species. Pathogens with high infectivity cause disease with relatively few organisms, while those with low infectivity require a larger number. High infectivity does not necessarily mean that the symptoms and signs of disease appear more quickly, nor that the illness is more severe.
- c. *Virulence.* The virulence of an agent reflects the relative severity of disease produced by that agent. Different microorganisms and different strains of the same microorganism may cause diseases of different severity.
- d. *Toxicity.* The toxicity of an agent reflects the relative severity of illness or incapacitation produced by a toxin.
- e. *Pathogenicity.* This reflects the capability of an infectious agent to cause disease in a susceptible host.
- f. *Incubation Period.* A sufficient number of microorganisms or quantity of toxin must penetrate the body to initiate infection (the infective dose), or intoxication (the intoxicating dose). Infectious agents must then multiply (replicate) to produce disease. The time between exposure and the appearance of symptoms is known as

- the incubation period. This is governed by many variables, including: the initial dose; virulence; route of entry; rate of replication; and host immunological factors.
- g. *Transmissibility*. Some biological agents can be transmitted from person-to-person directly. Indirect transmission (for example, via arthropod vectors) may be a significant means of spread as well. In the context of BW casualty management, the relative ease with which an agent is passed from person-to-person (that is, its transmissibility) constitutes the principal concern.
  - h. *Lethality*. Lethality reflects the relative ease with which an agent causes death in a susceptible population.
  - i. *Stability*. The viability of an agent is affected by various environmental factors, including temperature, relative humidity, atmospheric pollution, and sunlight. A quantitative measure of stability is an agent's decay rate (for example, "aerosol decay rate").
  - j. *Additionally Factors*. Additional factors which may influence the suitability of a microorganism or toxin as a biological weapon include: ease of production; stability when stored or transported; and ease of dissemination.

### 105. Classification.

- a. *Medical*. (See Annexes A and B.) Taxonomic classification of biological agents is important to the medical services in terms of detection, identification, prophylaxis, and treatment. Biological agents which may be used as weapons can be classified as follows:
  - (1) *Bacteria*. Bacteria are small free-living organisms, most of which may be grown on solid or liquid culture media. The organisms have a structure consisting of nuclear material, cytoplasm, and cell membrane. They reproduce by simple division. The diseases they produce often respond to specific therapy with antibiotics.
  - (2) *Viruses*. Viruses are organisms which require living cells in which to replicate. They are therefore intimately dependent upon the cells of the host which they infect. They produce diseases which generally do not respond to antibiotics but which may be responsive to antiviral compounds, of which there are few available, and those that are available are of limited use.
  - (3) *Rickettsiae*. Rickettsiae are microorganisms which have characteristics common to both bacteria and viruses. Like bacteria, they possess metabolic enzymes and cell membranes, utilize oxygen, and are susceptible to broad-spectrum antibiotics. They resemble viruses in that they grow only within living cells.
  - (4) *Chlamydia*. Chlamydia are obligatory intracellular parasites incapable of generating their own energy source. Like bacteria, they are responsive to broad-spectrum antibiotics. Like viruses, they require living cells for multiplication.
  - (5) *Fungi*. Fungi are primitive plants which do not utilize photosynthesis, are capable of anaerobic growth, and draw nutrition from decaying vegetable matter. Most fungi form spores, and free-living forms are found in soil. The

spore forms of fungi are operationally significant. Fungal diseases may respond to various antimicrobial.

- (6) **Toxins.** Toxins are poisonous substances produced and derived from living plants, animals, or microorganisms; some toxins may also be produced or altered by chemical means. Toxins maybe countered by specific antisera and selected pharmacologic agents.
- b. *Operational.* It may be considered useful to classify biological agents by the effects they produce in an operational context, in order to provide guidance to the field commander on the consequences for continued operational effectiveness. Annex C of this manual provides guidance for such a classification scheme by individual agent. Operational categories should incorporate all recognized variables likely to impact on effectiveness, to include lethality, transmissibility, and persistence.

## 106. Dissemination.

Dissemination is the process by which infectious diseases or toxins are dispersed to cause disease or intoxication. The same routes of entry pertinent to natural spread of diseases (that is, through inhalation, ingestion, or percutaneous inoculation) are also relevant when their etiologic agents are delivered intentionally by weapons. Biological agents are most likely to be delivered covertly and by aerosol. Other routes of entry are thought to be less important than inhalation but are nonetheless potentially significant.

### a. *Aerosol.*

#### (1) *Respiratory Exposure (Inhalation).*

(a) Inhalation of agent aerosols, with resultant deposition of infectious or toxic particles within alveoli, provides a direct pathway to the systemic circulation. The natural process of breathing causes a continuing influx of biological agent to exposed individuals. The major risk is pulmonary retention of inhaled particles. Droplets as large as 20 microns can infect the upper respiratory tract; however, these relatively large particles generally are filtered by natural anatomic and physiological processes, and only much smaller particles (ranging from 0.5-5 microns) reach the alveoli efficiently (Figure 1-I). Still smaller droplets are inhaled, but they are not efficiently retained in humans.

(b) Aerosol delivery systems aim to generate invisible clouds with particles or droplets between 0.5 and 10 microns in diameter which can remain suspended for long periods. Smaller sized particles are not efficiently retained by the human respiratory tract and are relatively unstable under ambient environmental conditions. Infection by the respiratory route may induce disease at doses lower than those generally associated with naturally-acquired infections by the oral route. The subsequent illness may differ from the natural pattern, and the incubation period may be much shorter.

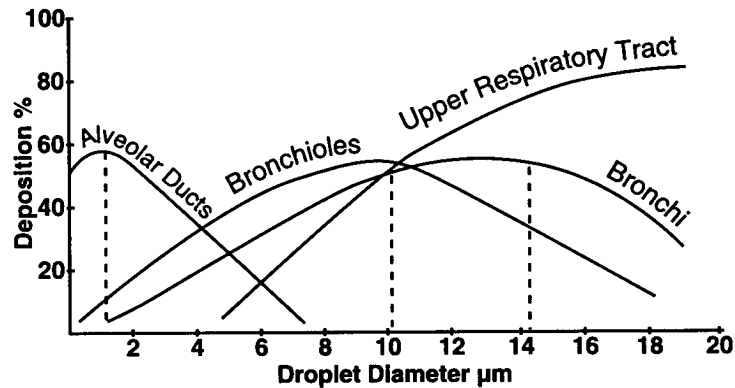


Figure 1-1. Droplet Size and Penetration of Respiratory Passages

- (2) *Alimentary Exposure (Ingestion)*. Food and water supplies may be contaminated during an aerosol BW attack. Unwary consumption of such contaminated materials could result in disease.
  - (3) *Dermal Exposure (Percutaneous)*. Intact skin provides an excellent barrier for most, but not all, biological agents. However, mucous membranes and damaged skin constitute breaches in this normal barrier through which agents may readily pass.
- b. *Contamination of Food and Water*. Direct contamination of consumables, such as drinking water, foodstuffs, or medications, could be used as a means to disseminate infectious agents or toxins. This method of attack would be most suitable for sabotage activities and might be used against limited targets such as water supplies or food supplies of a military unit or base. Filtration and adequate chlorination significantly reduce this hazard as it pertains to water.
- c. *Other Considerations*.
- (1) Attempts might be made to spread typical vector-borne diseases by releasing infected natural (or unnatural) arthropod hosts such as mosquitoes, ticks or fleas. These live vectors can be produced in large number and infected by allowing them to feed on infected animals, infected blood reservoirs, or artificially-produced sources of a biological agent.
  - (2) Long-term survival of infectious agents, preservation of toxin activity during extended periods, and the protective influence of dust particles onto which microorganisms adsorb when spread by aerosols have all been documented. The potential exists, therefore, for the delayed generation of secondary aerosols from previously contaminated surfaces. To a lesser extent, particles may adhere to an individual or to clothing creating additional but less significant exposure hazards.
  - (3) Person-to-person spread with certain potential biological agents has been documented. Humans, as unaware and highly effective carriers of a communicable agent, could readily become a source of dissemination (for example, with plague or smallpox).

## CHAPTER 2

## RECOGNITION

## SECTION I - INTRODUCTION

**201. Overview.**

With current technology, it is likely that a BW attack will be completed before the local commander, or his or her medical advisor, is aware that it has taken place. The medical officer must attempt to distinguish between an epidemic of natural origin and a BW attack. Specific considerations include:

- a. Biological agents are likely to be delivered covertly.
- b. Sick individuals may be the initial indication that an attack has occurred. Distinguishing a BW attack from background endemic disease may be difficult under some circumstances. Mixed infections or intoxications may occur thereby complicating or delaying diagnosis.
- c. A large number of casualties may occur during a short period of time.
- d. In a given geographic area, both military and civilian casualties will occur.
- e. Targets may be large geographical areas or smaller, tactically important, objectives. The size of an area in which casualties occur can help narrow the list of likely agents. For example, certain biological agents, like toxins, can be used most effectively on smaller targets, while others can be disseminated efficiently over extremely large areas (for example, anthrax spores).
- f. Rapid detection and definitive identification of suspected BW agents are essential for tactical and political as well as medical purposes.
- g. Atmospheric conditions are critical to the effective use of biological agents. In general, the optimal time for use of BW weapons is during the late night and early morning. It is during these hours that inactivation of biological aerosols by ultra-violet radiation is minimal. In addition, neutral or inversion conditions are most likely to be present at these times. The phenomenon of atmospheric inversion best allows an agent cloud to travel along the land surface.

## SECTION II - EPIDEMIOLOGY

**202. Difficulties in Detection.**

Human beings are a sensitive, and in some cases the only, biodetector. Early clinical findings may be nonspecific or atypical of the natural disease. Medical personnel maybe unable to differentiate natural disease from BW attacks. Considerable time may elapse following a BW attack before the extent of the exposure is appreciated.

### 203. Attack Indicators.

Following a BW attack, the disease pattern is likely to have characteristics that differ from those of a naturally-occurring epidemic.

- a. In contrast to naturally-occurring epidemics (excluding foodborne outbreaks) in which disease incidence increases over a period of weeks or months, the epidemic curve for most artificially-induced outbreaks is compressed, peaking within a few hours or days.
- b. In contrast to the peaks and troughs evident in most natural disease outbreaks, a steady and increasing stream of patients will be seen (comparable to that during a natural food poisoning outbreak).
- c. An understanding of disease ecology and epidemiology can be extremely useful in distinguishing natural outbreaks from those induced by biological weapons. For example, diseases which are naturally vector-borne will have environmental parameters which predispose to naturally occurring outbreaks. Appearance of disease in the absence of these parameters would be highly suggestive of a BW attack.
- d. Medical officers must maintain routine disease surveillance; emergence of an atypical pattern mandates immediate notification of higher authority. The simultaneous appearance of outbreaks in different geographical locations should alert commanders to the possibility of a biological agent attack. In addition, multiple agents may be used simultaneously in a BW attack, or chemical and biological agents may be combined in a single attack to confuse diagnosis.

### 204. Additional Attack Indicators.

Additional indicators of a BW attack include:

- a. A large number of casualties within the first 48-72 hours after the attack (suggesting an attack with a microorganism), or within minutes to hours (suggesting an attack with a toxin). The epidemiology would be that of a massive single source.
- b. A large number of clinical cases among exposed individuals (that is, a high attack rate).
- c. An illness type highly unusual for the geographic area (for example, Venezuelan equine encephalitis in Europe).
- d. An illness occurring in an unnatural epidemiological setting, where environmental parameters are not conducive to natural transmission (such as human Venezuelan equine encephalitis in the absence of antecedent disease in horses or in the absence of vector mosquitoes).
- e. An unusually high prevalence of respiratory involvement in diseases that, when acquired in nature, generally cause a non-pulmonary syndrome: the signature of aerosol exposure (for example, inhalation versus cutaneous anthrax; pneumonic versus bubonic plague; or, a primarily pneumonic versus enteric illness with staphylococcal enterotoxin (SEB)).
- f. Casualty distribution aligned with wind direction.
- g. Lower attack rates among those working indoors, especially in areas with filtered air



- or closed ventilation systems, than in those exposed outdoors.
- h. Increased numbers of sick or dead animals, often of different species. Most BW agents are capable of infecting/intoxicating a wide range of hosts.
  - i. Witness to an attack, or discovery of an appropriate delivery system (such as finding a contaminated bomblet or rocket from which an infectious agent is subsequently isolated and identified).
  - j. Large numbers of rapidly fatal cases, with few recognizable signs and symptoms, resulting from exposure to multiple lethal doses near the dissemination source.

### SECTION III - SAMPLE COLLECTION

#### 205. Diagnosis.

The accurate reporting of clinical findings may be critical in alerting other units to both the possibility and nature of a BW attack. Unfortunately, attempts to reach a firm diagnosis on clinical grounds alone may not be productive. Emerging technology will likely provide provisional diagnostic capabilities locally. However, establishing a definitive diagnosis will often require specialized laboratory facilities.

#### 206. Environmental Sampling.

General policies for collecting samples in order to facilitate identification of biological agents are essential. Medical responsibilities normally are limited to collection and submission of diagnostic materials from patients; environmental sampling is an important element in corroborating the occurrence of a BW attack, but is the responsibility of other agencies. Success or failure in providing a timely medical response will depend upon the rapidity and accuracy of the diagnostic effort, together with the transmittal of timely information from those organizations involved in environmental sampling.

#### 207. Sampling Principles.

General principles of the collection and processing of medical samples include the following:

a. *Specimen Collection.*

- (1) Blood culture with routine media will readily detect many bacterial agents, although specialized media may be required for some. Both aerobic and anaerobic cultures should be obtained routinely. Cultures and impression smears should be taken from involved lymph nodes, sputum, pleural fluid, cerebrospinal fluid (CSF), and spleen when possible.
- (2) Acute serum (at least 3 ml for suspected infectious agents, and at least 20 ml serum for suspected intoxications) should be collected as early as possible after onset of symptoms and shipped frozen to a reference laboratory. Blood samples also should be obtained from exposed persons who are not yet symptomatic. Convalescent sera from survivors and nonaffected unit members should be obtained 3-4 weeks later.

- (3) Samples for isolation of suspected viral agents should be obtained from organs and tissues as described above, and placed in specialized transport media and frozen for shipment to specified reference laboratories.
- (4) Tissue samples obtained at autopsy should be collected in multiple aliquots: minimally, one (25-50 gms) to freeze for microbiology or toxicology and one in formalin for histopathology should be obtained. Where possible additional specimens for specialized procedures such as immunofluorescence or polymerase chain reaction studies should be obtained. Organs sampled should include lung, mediastinal lymph nodes, spleen, and liver. Obvious lesions and adjacent normal tissue should be taken from affected areas in any organ. Postmortem blood (up to 20 ml) should be obtained and submitted as serum and clot or cells.

**b. Specimen Labelling.**

- (1) Each container should be labelled with name, numerical identities, type of specimen, and date of collection. Included should be a brief description of the illness and gross autopsy findings; place, date, and time of death; place, date, and time of collection; pathologists; and unit. Samples for microbiological or toxicological analysis should be kept as cold as possible, preferably frozen. Formalin-fixed material must not be frozen.
- (2) All serum samples should be completely labelled with patient's name, numerical identifier, unit, date, originating medical facility, and medical facility to receive results (if different from submitting facility). Routine laboratory slips should be included with each sample. Data on laboratory slips should include number of days since onset of symptoms and the reason that samples were obtained.
- (3) Clinical and operational data should be included for all samples, together with a form to establish chain of custody. This requirement must be strongly and clearly delineated since evidence may well be politically or militarily disputed.

**c. Specimen Handling and Shipment.**

- (1) All specimens from suspected BW casualties should be submitted through the routine diagnostic laboratory chain for processing. Samples must be clearly marked for special diagnostic testing, and chain-of-custody procedures maintained.
- (2) Serum should be contained in plastic screw-cap vials, which are securely sealed. If possible, each serum sample should be individually placed in a second plastic vial or zip-top bag to prevent leakage. All specimens should be contained in a metal shipping can or other secondary container. Sufficient absorbent material should be packed to prevent leakage outside the container. The entire contents should be placed in an insulated shipping container with cold packs or dry ice.
- (3) It is the responsibility of the laboratory officer, in concert with the physician, to ensure that suspect specimens are submitted correctly and expeditiously to an appropriate diagnostic laboratory.

**SECTION IV - IDENTIFICATION OF SPECIFIC BW AGENTS****208. Identification Methods.**

Methods of identification of BW agents include:

- a. Isolation of the etiologic agent by culture (possible in one to two days for some agents).
- b. Detection of toxin by mass spectroscopy, animal inoculation, or other methods.
- c. Antibody detection (specific immunoglobulin M (IgM) may appear within 3 days).
- d. Antigen detection via enzyme immunoassay or other sensitive assay methods.
- e. Genome detection employing DNA probes.
- f. Detection of metabolic products of the infectious or toxic agent in clinical specimens.

**SECTION V - PSYCHOLOGICAL EFFECTS****209. Psychological Impact.**

The term "biological warfare" may provoke feelings of horror; even if the direct effects of a recognized biological attack were slight, the psychological impact of this invisible, intangible threat could lead to panic and collapse of morale. There may be an accompanying loss of confidence in individual protective equipment and medical countermeasures, all of which may have serious repercussions on the military operation.

**210. Effect on Individuals.**

On the battlefield, there are many psychological pressures on the individual. Command, control, and communications will be made more difficult by the wearing of respirators. The psychological effect of biological attack on the individual and the unit must be considered in a full nuclear, biological, and chemical (NBC) context.

**211. Psychological Operations.**

Enemy saboteurs may be used as panic mongers for the purpose of spreading rumours of a biological attack. The effectiveness of such psychological operations would depend largely on the mental preparedness of the target populations. For operations in which biological warfare is considered possible, each case of illness on the battlefield could be attributed to a biological attack; even minor symptoms might be interpreted as the initial signs of an artificially-produced disease. Control of panic and misinformation thus assumes a significant role.

**212. Countermeasures.**

- a. An adequate appreciation of the threat, together with the implementation of defensive measures, will help to prevent panic. This can be achieved only by adequate preparation (for example, standard operating procedures) and by training prior to such an attack. Many positive defensive measures can be taken prior to, or in

- anticipation of, this contingency. Food chains and water sources should be protected. The control of rodents and insects should be a hygiene priority. Available biological detection equipment and decontamination equipment should be fielded. Soldiers must be trained in the proper use and rapid deployment of individual protective equipment (IPE). Attention to such preparatory measures will increase confidence and enable the BW threat to be met.
- b. Defensive measures should not be limited to the military population. Civilian populations are unlikely to have any form of specialized protective equipment. Moreover, civilian medical services do not routinely plan for biological warfare casualties. It is imperative that medical planning include coordination between military and civilian medical authorities in order to minimize casualties and prevent panic. As an initial step, such fundamental concepts as protection of food and water supplies, creation of rudimentary collective protection (colpro) shelters, and the effectiveness of hygiene and sanitation in an NBC environment might be introduced.

## CHAPTER 3

## DEFENSE

## SECTION I - INTRODUCTION

**301. General.**

In striking contrast to medical defensive measures to counter the effects of conventional, nuclear, and many chemical weapons, there exists the potential to minimize the threat of biological warfare through employment of available prophylaxis and therapy directed against specific agents.

**302. Sanitation.**

The importance of effective hygiene and sanitation in a biological operations environment cannot be over-emphasized. One of the primary responsibilities of all personnel is to ensure that standards of hygiene are maintained even in the most difficult circumstances. Personal hygienic measures such as frequent and adequate washing with soap and water, regular changes with laundered clothing, use of liberally disinfected toilets and field latrines (as opposed to cat-scratch methods), and post-defecation hand-washing should be emphasized.

**303. Food and Water Sanitation.**

Attention to published standards of safe food preparation and water purification, and protection of food and water supplies from incidental airborne contamination or sabotage, are likewise important. Standard methods of disinfection and waste disposal, effective in curbing transmission of naturally-occurring microorganisms, are equally useful in the context of biological warfare. Since biological agents may be spread by mechanical means or natural vectors, effective control of rodents and arthropods is a hygiene priority.

## SECTION II - WARNING AND DETECTION

**304. Detection.**

Adequate and accurate intelligence is required in order to develop an effective defense against biological warfare. Once an agent has been dispersed, detection of the biological aerosol prior to its arrival over the target in time for personnel to don protective equipment, is the best way to minimize or prevent casualties. In the absence of prior warning, detectors collocated with personnel constitute the only means of detecting biological agent attacks prior to the occurrence of disease among its victims. Such detector systems are evolving and represent an area of intense interest within the research and development community. The principal difficulty in detecting biological agent aerosols stems from differentiating the artificially generated BW cloud from the background of organic matter normally present in the atmosphere.

**SECTION III - PROTECTIVE EQUIPMENT****305. Individual Protection.**

- a. The NBC respirator, suit, gloves, and boots (IPE) will provide protection against a biological agent attack delivered by the aerosol route. Currently fielded respirators equipped with standard NBC filter canisters will protect the respiratory system against particles greater than 1-1.5 micrometers in size (mass median diameter). While the IPE clothing employed against chemical agents will also protect against biological agents, it is important to note that even standard uniform clothing of good quality affords a reasonable protection against dermal exposure to the surfaces covered.
- b. Those casualties unable to continue wearing IPE should be held and/or transported within casualty wraps designed to protect the patient against chemical or biological agent exposure. Addition of a filter blower unit to provide overpressure enhances protection and provides cooling.

**306. Collective Protection.**

- a. A dedicated hardened or unhardened shelter equipped with an air filtration unit (AFU) providing overpressure can offer collective protection (Colpro) for personnel in the biologically-contaminated environment. An airlock ensures that no contamination will be brought into the shelter. Casualties and contaminated personnel must be decontaminated prior to entering Colpro. In the absence of a dedicated structure, enhanced protection can be afforded within most buildings by sealing cracks and entry ports and providing air filtration within existing ventilation systems.
- b. Due to the requirement to continue operations in a contaminated environment, much medical treatment will likely take place in Colpro. Colpro is the most effective method for protecting patients and the medical capability in the contaminated environment. Patients whose illness is thought to be the result of a biological attack, or those who are thought to have a contagious infectious disease, will necessarily be cared for using barrier nursing techniques while inside the Colpro system.

**SECTION IV - IMMUNOPROPHYLAXIS AND CHEMOPROPHYLAXIS****307. Immunoprophylaxis.**

- a. Prophylactic immunization is the only means of providing continuous protection against BW threats prior to, as well as during, hostile actions. Vaccines against a number of potential BW agents are available, and others are in various stages of development. Many of these vaccines were developed for the protection of laboratory workers or individuals working where the target diseases are endemic.
- b. During a biological aerosol attack, the number of infectious or toxic units to which an individual is exposed may be greater than in the case of natural exposure. In addition, exposure by inhalation may represent an unnatural route of infection with

many agents. The efficiency of protection afforded by most vaccines is based on normal (that is, under natural disease conditions) inoculum size and exposure. Vaccines which generally are considered effective under natural circumstances may not provide a similar degree of protection to individuals exposed to biological aerosols.

- c. Administration of vaccines to counter biological agents is complicated by the number of potential threats, the requirement to administer multiple doses of certain vaccines, the lead time necessary for stimulating immunity through vaccination, and the number of vaccines that can be administered simultaneously. The logistical burden accompanying an in-theatre vaccine administration program can be eliminated by immunization prior to initiation of hostilities. This requires formulation and implementation of an immunization policy.
- d. Current or potential approaches to improving the efficiency of mass vaccination include: utilization of the jet injector, administration of vaccines via the aerosol route, use of immunopotentiators to enhance responsiveness to vaccines, development of new vaccines to accelerate the immune response, and use of multivalent vaccines.
- e. Vaccine reactogenicity must be considered in the operational decision to implement a vaccination policy. Idiosyncratic reactions are associated with nearly all vaccines but affect only a very small proportion of vaccinees. The frequency and severity of reactions vary from vaccine to vaccine. With current products, significant side effects of immunization generally occur infrequently.
- f. For some biological agents, the only available countermeasure might be specific antiserum. Under certain conditions, passive immunoprophylaxis with immunoglobulin products might be considered. Use may be limited by lack of adequate sources and quantities of material, limited duration of protection, and the risk of serum sickness associated with antisera not of human origin. However, recent scientific advances in products for immunoprophylaxis (for example, human monoclonal antibodies, "despeciated" equine or bovine antisera) are making this option technically more attractive.

### **308. Chemoprophylaxis.**

- a. Chemoprophylaxis using broad-spectrum antibiotics offers an additional option in the setting of a biological warfare threat. If an attack is felt to be imminent, or is known to have occurred, directed chemoprophylaxis would be appropriate for all personnel in the area. However, it is impractical, wasteful, and dangerous to place everyone located in a potential target area on prolonged, routine prophylactic antibiotics in the absence of such a threat condition.
- b. For some biological agents, administration of antibiotics following exposure, but prior to appearance of symptoms, may be lifesaving. Knowledge of incubation periods and disease pathogenesis must be considered in the rationale and timing for dose and schedule of administration for a given drug. In some cases (for example, inhalation anthrax), coupling antibiotics with the post-exposure use of vaccine may offer the best alternative in those previously unvaccinated. In other cases,

administration of antibiotics at certain times following exposure serves only to prolong the incubation period (for example, Q fever). One must, therefore, be cautious in generalizing in the decisions to employ post-exposure prophylaxis.



## CHAPTER 4

## MANAGEMENT

## SECTION I - INTRODUCTION

**401. Management Approach.**

Precise diagnosis of biological agent casualties in an NBC environment is likely to be difficult. Both casualties and medical personnel may be in full IPE. Signs and symptoms of biological agent infection or intoxication are common to many diseases. Biological warfare casualties may coexist with conventional, nuclear and/or chemical warfare casualties. Adequate or appropriate laboratory facilities may not be available. The treatment required for BW casualties will not differ in basic principle from that in patients suffering from the same disease incurred by natural means, but the approach to management will necessarily differ from that used in peacetime.

## SECTION II - CASUALTY DECONTAMINATION

**402. Decontamination of Exposed Personnel.**

- a. **Primary Contamination.** Dermal exposure from a suspected BW attack should be managed by decontamination at the earliest opportunity. In the absence of agent-specific guidance, exposed areas should be cleansed using an appropriately diluted sodium hypochlorite solution (0.5%) or copious quantities of plain soap and water. This should follow any needed use of decontaminants for chemical agents but should be prompt. Potentially contaminated clothing should be removed as soon as is practical by protected personnel (that is, in full IPE) in an area away from non-contaminated patients. Following decontamination, the casualty should be protected from further exposure if transported or cared for outside a Colpro system.
- b. **Secondary Contamination.** Secondary contamination of medical personnel from clothing or equipment of exposed soldiers may be important. This is particularly worrisome from casualties recently exposed near the dissemination source where high levels of contamination may occur. Since it will be difficult to distinguish those soldiers exposed near the source from those contaminated some distance away, proper physical protection of health care providers or other persons handling exposed personnel should be maintained until decontamination is complete.

## SECTION III - TREATMENT

**403. Principles of Treatment.**

- a. **General Supportive Measures.** Measures should be taken to lower temperature; relieve pain; maintain spontaneous respiration; and secure an intravenous access for

- the administration of drugs and fluids. Symptomatic treatment and treatment of coexisting injuries should follow established principles.
- b. *Isolation Procedures (Barrier Nursing)*. In the context of biological agent casualties, adherence to principles of patient isolation is essential to preventing cross-infection with transmissible agents. Separation of non-affected individuals from contaminated victims of biological agent attack (cohorting; reverse quarantine) and implementation of barrier nursing procedures should be initiated as soon as practical after a BW incident.
  - c. *Antibiotic Therapy*. Antibiotics must be given to all BW casualties, even without a firm diagnosis. Most bacterial, chlamydial, and rickettsial diseases respond to antibiotics. The choice of drug depends on the clinical circumstances, but one broad-spectrum antibiotic should be administered in full therapeutic doses, parenterally if possible, and preferably intravenously, and commenced at the earliest possible level of medical care. The choice of antibiotic will depend upon many factors, including the specific threat or threats, evidence or suspicion of natural antibiotic resistance among strains, and the ease with which drug resistance can be artificially engineered. Where applicable, specific guidelines are included in Annex B.
  - d. *Antiviral Therapy*. The only "broad-spectrum" antiviral drug currently available is ribavirin. This compound has been a useful adjunct to the treatment of some potential viral threats when they have occurred under natural conditions (Lassa fever, Crimean-Congo hemorrhagic fever, hemorrhagic fever with renal syndrome). In addition, there is evidence of antiviral activity *in vitro* and *in vivo* against certain other viruses (influenza, Junin virus, Rift Valley fever (RVF) virus), but little or no activity is seen with other (filoviruses, togaviruses) agents. Other antiviral drugs, such as amantadine, acyclovir, and azidothymidine, are restricted in their therapeutic spectrum to single virus families, and thus have little application as non-specific antiviral. Where applicable, specific guidelines are included in Annex B.
  - e. *Antitoxin Therapy*. Specific antitoxins are available for certain conditions. Where applicable, specific guidelines are included in Annex B. No broad-spectrum antitoxins currently exist.

#### SECTION IV - PROTECTION OF HEALTH CARE PERSONNEL

##### 404. Use of Barrier Techniques.

Following decontamination, patients are cared for using standard nursing management techniques including universal infectious disease precautions (barrier nursing). Protection of medical personnel is offered through use of impermeable surgical gowns/oral-nasal masks/face shields or goggles/surgical gloves and observance of universal (body fluid) precautions/barrier nursing techniques.

##### 405. Potential Biological Hazards.

Significant risk for person-to-person spread may exist for individuals *not* directly involved in patient care. In particular, materials soiled by patient secrets and excreta, as well as

samples for diagnostic laboratory study, must be clearly identified as hazardous and appropriate handling procedures applied. Similarly, invasive medical and surgical procedures pose potential risks. It must be emphasized, however, that not all biological agents pose a hazard for secondary transmission. (See Annex C for specific concerns.) For example, clinical laboratory samples from toxin-exposed subjects can be dealt with routinely. Patients showing signs of pneumonic plague generally should be considered hazardous, as some will disperse plague bacilli by aerosol. Although cutaneous anthrax may result from contact with blood or other body fluids contaminated with vegetative anthrax bacilli, exposure of health care providers to open lesions or blood from anthrax patients does not pose a risk of inhalation anthrax. Bacilli exposed to air, however, will sporulate (after a period of hours). This will pose a subsequent theoretical risk for inhalation anthrax. On the other hand, vegetative forms of plague bacilli may be dangerous, since, under some circumstances, they are known to cause aerosol infections. Therefore, postmortem examinations of victims of transmissible biological agents should be performed using barrier techniques, with appropriate consideration given to specific respiratory protection.

## SECTION V - HANDLING OF CONTAMINATED REMAINS

### 406. General Considerations.

The handling of biologically contaminated remains within the medical system is a medical responsibility. However, the disposal of biologically contaminated remains on the battlefield or after removal from the medical system is not a medical responsibility.

### 407. Risk Avoidance Procedures.

Those charged with the responsibility for handling and disposing of biologically contaminated remains must be cognizant of potential secondary transmission hazards. Corpses should be interred according to current NATO procedures until definitive decontamination measures are implemented. Interment for a period of days permits natural chemical and microbiological decomposition processes to reduce or eliminate any later risk from toxins, viruses, and non spore-forming bacteria. Current evidence indicates that remains contaminated with spore-forming bacteria can be reliably sterilized only by complete incineration. However, alternative decontamination schemes may be employed which could reduce spore burdens to levels acceptable with regard to later transmission risk.

## SECTION VI - MASS CASUALTY MANAGEMENT

### 408. Basic Care Provisions.

There will be significant differences in the methods of providing basic medical care in mass casualty situations.

**409. Facilities.**

If physical facilities have been destroyed by other means of warfare, most civilian casualties will be cared for in the home; military casualties may well be treated by unit medical personnel rather than being moved to a hospital. Unlike a typical mass casualty situation, few of these patients will require surgery.

**410. Equipment.**

For the vast majority of patients, no special equipment, such as x-ray facilities, oxygen therapy, or surgical equipment, will be needed. Biological toxins are an important exception, where dramatic, acute signs such as respiratory paralysis would necessitate various types of advanced equipment (for instance, mechanical ventilators).

**411. Level of Care.**

If the biological agent causes an illness that results in relatively few deaths (for example, Venezuelan equine encephalitis, Q fever), medical care can be effectively provided on the local level. If the disease is one for which specific therapy such as antibiotics is indicated (for example, tularaemia), instructions for obtaining and administering the drug should be disseminated. With a disease like yellow fever, with high mortality and for which no specific therapy is available, instructions for general supportive care that might be provided by non-medical personnel should be disseminated.

**412. Staggered Effect of Biological Agents.**

Although many individuals becoming ill from an attack with a biological weapon would likely present for medical evaluation over a short time span, all would not become casualties simultaneously, as they would for example, following saturation bombing or a massive surprise attack with nerve gas. An exception to this pattern might be seen following an attack with a biological toxin.

**413. Effective Duty Period.**

Those who had been infected by a biological agent could remain functional for a period of time after the attack (during the incubation period). However, a return to duty might not be advisable until an etiological diagnosis had been established.

**414. Employment of Physicians.**

It may be necessary for one physician, with a small number of ancillary personnel, to care for several hundred patients. Information could be disseminated about the normal course of the disease, the specific signs or symptoms of adverse prognostic significance, the situations requiring individual medical attention or advice, and the procedures for obtaining essential

medical supplies. This arrangement would allow a limited number of professional personnel to care for the maximum number of patients.

**415. Psychological Considerations.**

An essential aspect of medical management in such a situation would be to allay panic. This could be done effectively only if everyone in the area (both civilian and military) could be assured that the cause of the illness is known, the course of the disease could be described with reasonable accuracy, and the outcome could be predicted. This type of assurance could be provided only if an accurate etiologic diagnosis can be made shortly after the onset of illness. If this assurance cannot be provided, the psychological response might create greater problems than the disease itself.

**NATO HANDBOOK ON MEDICAL ASPECTS  
OF NBC DEFENSIVE OPERATIONS  
AMedP-6(B)**

**PART II - BIOLOGICAL**

**ANNEX A**

**MEDICAL CLASSIFICATION OF POTENTIAL BIOLOGICAL WARFARE AGENTS**

**1 FEBRUARY 1996**

**TABLE OF CONTENTS**

	<b>Page</b>
Table A-I. Potential Biological Agents	A-3

THIS PAGE HAS BEEN LEFT INTENTIONALLY BLANK



ANNEX A

MEDICAL CLASSIFICATION OF POTENTIAL BIOLOGICAL WARFARE AGENTS

Table A-I shows those diseases whose causative organisms have been considered as potential biological agents. Its contents should not be construed as a sanctioned threat list.

*Table A-I. Potential Biological Agents*

Agent	Disease
Bacterial	Anthrax Brucellosis Cholera Meliodosis Plague (pneumonic) Shigella Tularemia Typhoid fever
Rickettsial	Epidemic typhus Q fever Rocky Mountain spotted fever Scrub typhus
Chlamydial	Psittacosis
Fungal	Coccidioidomycosis Histoplasmosis
Viral	Argentine hemorrhagic fever Bolivian hemorrhagic fever Chikungunya fever Crimean-Congo hemorrhagic fever Dengue fever Ebola Eastern equine encephalitis Influenza Korean hemorrhagic fever (Hantaan) Lassa Omsk hemorrhagic fever Rift Valley fever

*Table A-I. Potential Biological Agents (continued)*

Agent	Disease
	Russian spring-summer encephalitis Smallpox Venezuelan equine encephalitis Yellow fever
Toxins	Botulinum toxins Clostridium perfringens toxins Mycotoxins of trichothecene group Palytoxin Ricin Saxitoxin Staphylococcal enterotoxins Tetrodotxin

**NATO HANDBOOK ON THE MEDICAL ASPECTS  
OF NBC DEFENSIVE OPERATIONS  
AMedP-6(B)**

**PART II - BIOLOGICAL**

**ANNEX B**

**CLINICAL DATA SHEETS FOR SELECTED BIOLOGICAL AGENTS**

**1 FEBRUARY 1996**

**TABLE OF CONTENTS**

	Page
Paragraph B.01. Introduction	B-3
B.02. Anthrax	B-3
B.03. Botulinum Toxins	B-6
B.04. Brucellosis	B-8
B.05. Cholera	B-9
B.06. Clostridium Perfringens Toxins	B-10
B.07. Crimean-Congo Hemorrhagic Fever	B-11
B.08. Melioidosis	B-13
B.09. Plague	B-14
B.10. Q Fever	B-16
B.11. Ricin	B-16
B.12. Rift Valley Fever	B-18
B.13. Saxitoxin	B-20
B.14. Smallpox	B-21
B.15. Staphylococcal Enterotoxin B	B-24
B.16. Trichothecene Mycotoxins	B-25
B.17. Tularemia	B-27
B.18. Venezuelan Equine Encephalitis	B-28

THIS PAGE HAS BEEN LEFT INTENTIONALLY BLANK

## ANNEX B

## CLINICAL DATA SHEETS FOR SELECTED BIOLOGICAL AGENTS

**B.01. Introduction.**

- a. The following information provides clinical information to assist in the recognition, diagnosis and management of selected diseases, well recognized for their potential as biological weapons. It is not intended to be comprehensive, nor should it be interpreted as a sanctioned "threat list." Likely agents are:
- (1) Anthrax.
  - (2) Botulinum Toxins.
  - (3) Brucellosis.
  - (4) Cholera.
  - (5) Clostridium Perfringens Toxins.
  - (6) Crimean-Congo Hemorrhagic Fever.
  - (7) Melioidosis.
  - (8) Plague.
  - (9) Q Fever.
  - (10) Ricin.
  - (11) Rift Valley Fever.
  - (12) Saxitoxin.
  - (13) Smallpox.
  - (14) Staphylococcal Enterotoxin B.
  - (15) Trichothecene Mycotoxins.
  - (16) Tularemia.
  - (17) Venezuelan Equine Encephalitis.
- b. Many products referenced in this annex are currently considered investigational new drugs (IND). This indicates that the product (drug, vaccine, antitoxin, etc.) has been shown to be safe and effective in animal studies and has been approved for limited use as an investigational product in humans. In general, IND products must be obtained through official channels from the government of the producing nation and administered under a research protocol approved by a recognized institutional review board.

**B.02. Anthrax.***a. Clinical Syndrome.*

- (1) *Characteristics.* Anthrax is a zoonotic disease caused by *Bacillus anthracis*. Under natural conditions, humans become infected by contact with infected animals or contaminated animal products. Human anthrax is usually manifested by cutaneous lesions. A biological warfare attack with anthrax spores delivered by aerosol would cause inhalation anthrax, an extraordinarily rare form of the naturally occurring disease.

- (2) *Clinical Features.* The disease begins after an incubation period varying from 1-6 days, presumably dependent upon the dose of inhaled organisms. Onset is gradual and nonspecific, with fever, malaise, and fatigue, sometimes in association with a nonproductive cough and mild chest discomfort. In some cases, there may be a short period of improvement. The initial symptoms are followed in 2-3 days by the abrupt development of severe respiratory distress with dyspnea, diaphoresis, stridor, and cyanosis. Physical findings may include evidence of pleural effusions, edema of the chest wall, and meningitis. Chest x-ray reveals a dramatically widened mediastinum, often with pleural effusions, but typically without infiltrates. Shock and death usually follow within 24-36 hours of respiratory distress onset.

b. *Diagnosis.*

- (1) *Routine Laboratory Findings.* Laboratory evaluation will reveal a neutrophilic leucocytosis. Pleural and cerebrospinal fluids may be hemorrhagic.
- (2) *Differential Diagnosis.* An epidemic of inhalation anthrax in its early stage with nonspecific symptoms could be confused with a wide variety of viral, bacterial, and fungal infections. Progression over 2-3 days with the sudden development of severe respiratory distress followed by shock and death in 24-36 hours in essentially all untreated cases eliminates diagnoses other than inhalation anthrax. The presence of a widened mediastinum on chest x-ray, in particular, should alert one to the diagnosis. Other suggestive findings include chest-wall edema, hemorrhagic pleural effusions, and hemorrhagic meningitis. Other diagnoses to consider include aerosol exposure to SEB; but in this case onset would be more rapid after exposure (if known), and no prodrome would be evident prior to onset of severe respiratory symptoms. Mediastinal widening on chest x-ray will also be absent. Patients with plague or tularemia pneumonia will have pulmonary infiltrates and clinical signs of pneumonia (usually absent in anthrax).
- (3) *Specific Laboratory Diagnosis.* *Bacillus anthracis* will be readily detectable by blood culture with routine media. Smears and cultures of pleural fluid and abnormal cerebrospinal fluid may also be positive. Impression smears of mediastinal lymph nodes and spleen from fatal cases should be positive. Toxemia is sufficient to permit anthrax toxin detection in blood by immunoassay.

- c. *Therapy.* Almost all cases of inhalation anthrax in which treatment was begun after patients were symptomatic have been fatal, regardless of treatment. Historically, penicillin has been regarded as the treatment of choice, with 2 million units given intravenously every 2 hours. Tetracycline and erythromycin have been recommended in penicillin-sensitive patients. The vast majority of anthrax strains are sensitive in vitro to penicillin. However, penicillin-resistant strains exist naturally, and one has been recovered from a fatal human case. Moreover, it is not difficult to induce resistance to penicillin, tetracycline, erythromycin, and many other antibiotics through laboratory manipulation of organisms. All naturally occurring strains tested to date have been sensitive to erythromycin,

chloramphenicol, gentamicin, and ciprofloxacin. In the absence of information concerning antibiotic sensitivity, treatment should be instituted at the earliest signs of disease with oral ciprofloxacin ( 1000 mg initially, followed by 750 mg po (orally) bid (twice daily)) or intravenous doxycycline (200 mg initially, followed by 100 mg q (every) 12 hrs). Supportive therapy for shock, fluid volume deficit, and adequacy of airway may all be needed.

d. *Prophylaxis.*

- (1) *Vaccine.* A licensed, alum-precipitated preparation of purified *B. anthracis* protective antigen (PA) has been shown to be effective in preventing or significantly reducing the incidence of inhalation anthrax. Limited human data suggest that after completion of the first three doses of the recommended six-dose primary series (0, 2, 4 weeks, then 6, 12, 18 months), protection against both cutaneous and inhalation anthrax is afforded. Studies in rhesus monkeys indicate that good protection is afforded after two doses (10-16 days apart) for up to 2 years. It is likely that two doses in humans is protective as well, but there is too little information to draw firm conclusions. As with all vaccines, the degree of protection depends upon the magnitude of the challenge dose; vaccine-induced protection is undoubtedly overwhelmed by extremely high spore challenge. At least three doses of the vaccine (at 0, 2, and 4 weeks) are recommended for prophylaxis against inhalation anthrax. Contraindications for use are sensitivity to vaccine components (formalin, alum, benzethonium chloride) and/or history of clinical anthrax. Reactogenicity is mild to moderate: up to 6% of recipients will experience mild discomfort at the inoculation site for up to 72 hours (tenderness, erythema, edema, pruritus), while a smaller proportion (<1%) will experience more severe local reactions (potentially limiting use of the extremity for 1-2 days); modest systemic reactions (myalgia, malaise, low-grade fever) are uncommon, and severe systemic reactions (anaphylaxis, which precludes additional vaccination) are rare. The vaccine should be stored at refrigerator temperature (not frozen).
- (2) *Antibiotics.* Choice of antibiotics for prophylaxis is guided by the same principles as that for treatment; i.e., it is relatively easy to produce a penicillin-resistant organism in the laboratory, and possible, albeit somewhat more difficult, to induce tetracycline resistance. Therefore, if there is information indicating that a biological weapon attack is imminent, prophylaxis with ciprofloxacin (500 mg po bid), or doxycycline (100 mg po bid) is recommended. If unvaccinated, a single 0.5 ml dose of vaccine should also be given subcutaneously. Should the attack be confirmed as anthrax, antibiotics should be continued for at least 4 weeks in all exposed. In addition, two 0.5 ml doses of vaccine should be given 2 weeks apart in the unvaccinated; those previously vaccinated with fewer than three doses should receive a single 0.5 ml booster, while vaccination probably is not necessary for those who have received the initial three doses within the previous 6 months (primary series). Upon discontinuation of antibiotics, patients should be closely observed; if clinical signs of anthrax occur, patients should be



treated as indicated above. If vaccine is not available, antibiotics should be continued beyond 4 weeks until the patient can be closely observed upon discontinuation of therapy.

### B.03. Botulinum Toxins.

#### a. *Clinical Syndrome.*

- (1) *Characteristics.* Botulism is caused by intoxication with the any of the seven distinct neurotoxins produced by the bacillus, *Clostridium botulinum*. The toxins are proteins with molecular weights of approximately 150,000, which bind to the presynaptic membrane of neurons at peripheral cholinergic synapses to prevent release of acetylcholine and block neurotransmission. The blockade is most evident clinically in the cholinergic autonomic nervous system and at the neuromuscular junction. A biological warfare attack with botulinum toxin delivered by aerosol would be expected to cause symptoms similar in most respects to those observed with food-borne botulism.
- (2) *Clinical Features.* Symptoms of inhalation botulism may begin as early as 24-36 hours following exposure or as late as several days. Initial signs and symptoms include ptosis, generalized weakness, lassitude, and dizziness. Diminished salivation with extreme dryness of the mouth and throat may cause complaints of a sore throat. Urinary retention or ileus may also occur. Motor symptoms usually are present early in the disease; cranial nerves are affected first with blurred vision, diplopia, ptosis, and photophobia. Bulbar nerve dysfunction causes dysarthria, dysphonia, and dysphagia. This is followed by a symmetrical, descending, progressive weakness of the extremities along with weakness of the respiratory muscles. Development of respiratory failure may be abrupt. On physical examination, the patient is alert, oriented, and afebrile. Postural hypotension may be present. Ocular findings may include ptosis, extracellular muscle paralysis, and fixed and dilated pupils. Mucous membranes of the mouth may be dry and crusted. Neurological examination shows flaccid muscle weakness of the palate, tongue, larynx, respiratory muscles, and extremities. Deep tendon reflexes vary from intact to absent. No pathologic reflexes are present, and the sensory examination generally is normal (although reports suggest that obtundation or sensory involvement may sometimes occur).

#### b. *Diagnosis.*

- (1) *Routine Findings.* Routine laboratory findings are of no value in diagnosis. The cerebrospinal fluid is normal.
- (2) *Differential Diagnosis.* The occurrence of an epidemic with large numbers of afebrile patients with progressive ocular, pharyngeal, respiratory, and muscular weakness and paralysis hints strongly at the diagnosis. Single cases may be confused with various neuromuscular disorders such as atypical Guillain-Barré syndrome, myasthenia gravis, or tick paralysis. The edrophonium (tensilon) test may be transiently positive in botulism. Other considerations include enteroviral infections; but in these patients, fever is

present, paralysis is often asymmetrical, and the cerebrospinal fluid is abnormal. It may be necessary to distinguish nerve-agent and atropine poisoning from botulinum intoxication. Briefly, organophosphate nerve agent poisoning results in miotic pupils and copious secretions. In atropine poisoning, the pupils are dilated and mucous membranes are dry, but central nervous system excitation with hallucinations and delirium is present. (See Annex D for a more comprehensive differential.)

- (3) *Specific Laboratory Findings.* Detection of toxin in serum or gastric contents from cases of food-borne botulism is often feasible by mouse inoculation. Toxin has also been detected in serum following inhalation exposure in experimental animals. Serum should be obtained from representative cases for such attempts. Survivors probably will not develop an antibody response due to the small amount of toxin necessary to cause death.

c. *Therapy.*

- (1) Respiratory failure secondary to paralysis of respiratory muscles is the most serious complication and, generally, the cause of death. Reported cases of botulism prior to 1950 had a mortality of 60%. With tracheotomy and ventilator assistance, fatalities should be <5%. Intensive and prolonged nursing care may be required for recovery (which may take several weeks or even months).
- (2) In isolated cases of food-borne botulism, circulating toxin is usually present, perhaps due to continued absorption through the gut wall. Equine antitoxin has been used in these circumstances and is probably helpful. After aerosol exposure, antitoxin can be effective, sometimes even after onset of signs of intoxication. Administration of antitoxin is reasonable if disease has not progressed to a stable state.
- (3) There is no prospect for additional human antitoxin to be produced. A "despecciated" equine heptavalent antitoxin (vs types A, B, C, D, E, F, and G) has been prepared by cleaving the Fc fragments from horse immunoglobulin G (IgG) molecules, leaving F(ab)<sub>2</sub> fragments. Its efficacy is inferred from its performance in animal studies. Use requires pretesting for sensitivity to horse serum (and desensitization for those allergic). Disadvantages include rapid clearance by immune elimination, as well as a theoretical risk of serum sickness.

d. *Prophylaxis.*

- (1) A pentavalent toxoid of *Clostridium botulinum* types A, B, C, D, and E is available under IND status. This product has been administered to several thousand volunteers and occupationally at-risk workers and induces serum antitoxin levels that correspond to protective levels in experimental animal systems. The currently recommended schedule (0, 2, and 12 weeks, then a 1 year booster) induces solidly protective antitoxin levels in greater than 90 percent of those vaccinated after 1 year. Transient antitoxin levels are induced after three injections. Contraindications include sensitivity to alum, formaldehyde, and thimerosal, or hypersensitivity to a previous dose. Reactogenicity is mild, with 2-4% of vaccines reporting erythema, edema, or

induration which peaks at 24-48 hours then dissipates. The frequency of local reactions increases with each subsequent inoculation; after the second and third doses, 7-10% will have local reactions, with higher incidence (up to 20% or so) after boosters. Severe local reactions are rare, consisting of more extensive edema or induration. Systemic reactions are reported in up to 3%, consisting of fever, malaise, headache, and myalgia. Incapacitating reactions (local or systemic) are uncommon. The vaccine should be stored at refrigerator temperatures (not frozen).

- (2) Three or more vaccine doses (0, 2, and 12 weeks, then 1 year, if possible, by deep subcutaneous injection) are recommended only to selected individuals or groups judged at high risk for exposure to botulinum toxin aerosols. There is no indication at present for use of antitoxin as a prophylactic modality except under extremely specialized circumstances (for example, known impending exposure of small numbers of individuals).

#### **B.04. Brucellosis.**

##### *a. Clinical Syndrome.*

- (1) *Characteristics.* Brucellosis is a systemic zoonotic disease caused by one of four species of bacteria: *Brucella melitensis*, *B. abortus*, *B. suis*, and *B. canis*; virulence for humans decreases somewhat in the order given. These bacteria are small gram-negative, aerobic, non-motile coccobacilli that grow within monocytes and macrophages. They reside quiescently in tissue and bone-marrow, and are extremely difficult to eradicate even with antibiotic therapy. Their natural reservoir is domestic animals, such as goats, sheep, and camels (*B. melitensis*); cattle (*B. abortus*); and pigs (*B. suis*). *Brucella canis* is primarily a pathogen of dogs, and only occasionally causes disease in humans. Humans are infected when they inhale contaminated aerosols, ingest raw (unpasteurized) infected milk or meat, or have abraded skin or conjunctival surfaces that come in contact with the bacteria. Laboratory infections are quite common, but there appears to be no human-to-human transmission; isolation of infected patients is, therefore, not required. *Brucella* species long have been considered potential candidates for use in biological warfare. The organisms are readily lyophilized, perhaps enhancing their infectivity. Under selected environmental conditions (for example, darkness, cool temperatures, high CO<sub>2</sub>), persistence for up to 2 years has been documented. When used as a biological warfare agent, *Brucellae* would most likely be delivered by the aerosol route; the resulting infection would be expected to mimic natural disease.
- (2) *Clinical Features.* Brucellosis presents after an incubation period normally ranging from 3-4 weeks, but may be as short as 1 week or as long as several months. Clinical disease presents typically as an acute, non-specific febrile illness with chills, sweats, headache, fatigue, myalgias, arthralgias, and anorexia. Cough occurs in 15-25%, but the chest x-ray usually is normal. Complications include sacroiliitis, arthritis, vertebral osteomyelitis,

epididymo-orchitis, and rarely endocarditis. Physical findings include lymphadenopathy in 10-20% and splenomegaly in 20-30% of cases. Untreated disease can persist for months to years, often with relapses and remissions. Disability may be pronounced. Lethality may approach 6% following infection with *B. melitensis*, but the disease is rarely fatal (0.5% or less) after infection with other serotypes (usually after endocarditis develops).

b. *Diagnosis.*

(1) *Routine Laboratory Findings.* Noncontributory.

(2) *Differential Diagnosis.* The initial symptoms of brucellosis are usually nonspecific. The differential diagnosis is therefore very broad and includes bacterial, viral, and mycoplasmal infections. The systemic symptoms of viral and mycoplasmal illnesses, however, are usually present for only a few days, while they persist for prolonged periods in brucellosis. Brucellosis may be indistinguishable clinically from the typhoidal form of tularemia or from typhoid fever itself.

(3) *Specific Laboratory Diagnosis.* Serology by agglutination or enzyme-linked immunosorbant assay may suggest the diagnosis. A definitive diagnosis of brucellosis is established by culture of blood or bone marrow, which may be positive in up to 70% and 90% of cases, respectively.

c. *Therapy.* The recommended treatment is doxycycline (200 mg/day) plus rifampin (900 mg/day) for 6 weeks. Alternative effective treatment consists of doxycycline (200 mg/day) for 6 weeks plus streptomycin (1 gm/day) for 3 weeks. Trimethoprim-sulfamethoxazole given for 4-6 weeks is less effective. In 5-10% of cases, there may be relapse or treatment failure. Laboratory infections with brucellosis are quite common, but there is no human-to-human transmission and isolation is not required.

d. *Prophylaxis.* Killed and live attenuated human vaccines have been available in many countries but are of unproven efficacy. There is no information on the use of antibiotics for prophylaxis against human brucellosis.

## B.05. Cholera.

a. *Clinical Syndrome.*

(1) *Characteristics.* Cholera is a diarrheal disease caused by *Vibrio cholera*, a short, curved, gram-negative bacillus. Humans acquire the disease by consuming water or food contaminated with the organism. The organism multiplies in the small intestine and secretes an enterotoxin that causes a secretory diarrhea. When employed as a BW agent, cholera will most likely be used to contaminate water supplies. It is unlikely to be used in aerosol form.

(2) *Clinical Features.* Cholera may present as mild diarrhea or as a fulminant disease characterized by profuse watery diarrhea with fluid losses exceeding 5 to 10 liters or more per day. Without treatment, death may result from severe dehydration, hypovolemia and shock. Vomiting is often present early in the illness and may complicate oral replacement of fluid losses. There is little or no fever or abdominal pain.

b. *Diagnosis.*

- (1) *Routine Laboratory Findings.* On microscopic examination of stool samples there are few or no red cells or white cells. Serum electrolytes may demonstrate hypokalemia or if inappropriate fluid replacement has been given, may show hypernatremia or hyponatremia. Acidosis and renal failure may accompany severe dehydration.
- (2) *Differential Diagnosis.* Watery diarrhea can also be caused by enterotoxigenic *E. coli*, rotavirus or other viruses, noncholera *vibrios*, or food poisoning due to ingestion of preformed toxins such as those of *Clostridium perfringens*, *Bacillus cereus*, or *Staphylococcus aureus*.
- (3) *Specific Laboratory Diagnosis.* *Vibrios* can be identified in stool by darkfield or phase contrast microscopy, and *Vibrio cholera* can be grown on a variety of culture media. Bacteriologic diagnosis is not necessary to treat cholera or related watery diarrheas.

c. *Therapy.* Treatment of cholera depends primarily on replacement of fluid and electrolyte losses. This is best accomplished using oral dehydration therapy with the World Health Organization solution (3.5 g NaCl, 2.5 g NaHCO<sub>3</sub>, 1.5 g KCl and 20 g glucose per liter). Intravenous fluid replacement is occasionally needed when vomiting is severe, when the volume of stool output exceeds 7 liters/day, or when severe dehydration with shock has developed. Antibiotics will shorten the duration of diarrhea and thereby reduce fluid losses. Tetracycline (250 mg every 6 hr for 3-5 days) or doxycycline (200 mg initially followed by 100 mg every 12 hr for 3-5 days) is generally adequate. Other effective drugs include ampicillin (250 mg every 6 hr for 5 days) and trimethoprim sulfamethoxazole (one tablet every 12 hr for 3-5 days).

d. *Prophylaxis.* Improved oral cholera vaccines are presently being tested. Vaccination with the currently available killed suspension of *V. cholera* provides about 50% protection that lasts for no more than 6 months. The initial dose is two injections given at least 1 week apart with booster doses every 6 months.

## B.06. *Clostridium Perfringens* Toxins.

a. *Clinical Syndrome.*

- (1) *Characteristics.* *Clostridium perfringens* is a common anaerobic bacterium associated with three distinct disease syndromes; gas gangrene or clostridial myonecrosis; enteritis necroticans (pig-bel); and clostridium food poisoning. Each of these syndromes has very specific requirements for delivering inocula of *C. perfringens* to specific sites to induce disease, and it is difficult to imagine a general scenario in which the spores or vegetative organisms could be used as a biological warfare agent. There are, however, at least 12 protein toxins elaborated, and one or more of these could be produced, concentrated, and used as a weapon. Waterborne disease is conceivable, but unlikely. The alpha toxin would be lethal by aerosol. This is a well-characterized, highly toxic phospholipase C. Other toxins from the organism might be co-weaponized and enhance effectiveness. For example, the epsilon

toxin is neurotoxic in laboratory animals.

(2) *Clinical Features.* The clinical picture of aerosolized *C. perfringens* alpha toxin would be expected to be that of a serious acute pulmonary insult. Absorbed alpha toxin could produce vascular leak, hemolysis, thrombocytopenia, and liver damage. Other toxins admixed could modify the illness. There is insufficient information available to speculate on a clinical syndrome produced by other *C. Perfringens* toxins.

b. *Diagnosis.*

(1) *Routine Findings.* Clinical laboratory findings might include anemia (due to intravascular hemolysis), thrombocytopenia, elevated serum transaminases, and hypoxia.

(2) *Differential Diagnosis.* Pulmonary findings might lead to confusion with staphylococcal enterotoxin B (SEB) initially. Liver damage, hemolytic anemia, and thrombocytopenia are not associated with SEB and the pulmonary findings should be reversible in SEB.

(3) *Specific Laboratory Diagnosis.* Acute serum and tissue samples should be collected and rapidly transported to a reference laboratory. Specific immunoassay are available; however, their utility in diagnosis of human disease is unproven. The enterotoxin can be detected in fecal samples from human food poisoning cases, and bacteria are readily cultured from clinical samples.

c. *Therapy.* No specific treatment is available for *C. pefringens* intoxication. The organism itself is sensitive to penicillin, and consequently, this is the current drug of choice. Recent data indicate that clindamycin or rifampin may suppress toxin production and provide superior results in animal models.

d. *Prophylaxis.* There is no available prophylaxis against most *C. perfringens* toxins. Toxoids are being used to prevent enteritis necroticans in humans, and veterinary toxoids are in wide use.

## B.07. Crimean-Congo Hemorrhagic Fever.

a. *Clinical Syndrome.*

(1) *Characteristics.* Crimean-Congo hemorrhagic fever (CCHF) is a viral disease caused by CCHF virus. The virus is transmitted by ticks, principally of the genus *Hyalomma*, with intermediate vertebrate hosts varying with the tick species. The disease was first recognized in the Crimea, but occurs over most of Africa, the Middle East, the Balkans, the former USSR, and eastern China. Little is known about variations in the virus properties over the huge geographic area involved. Humans become infected through tick bites, crushing an infected tick, or at the slaughter of viremic livestock. (Domestic animals become infected but do not have significant disease.) The spread of disease within hospitals has been documented with this virus and poses a potentially significant problem. Even in epidemics, cases do not show narrow clustering and person-to-person spread is rare. CCHF would probably be

delivered by aerosol if used as a BW agent.

(2) *Clinical Features.*

(a) Typical cases present with sudden onset of fever and chills 3-12 days after tick exposure. Flushing, conjunctival injection, and mild hypotension may be present. After 2-3 days, perhaps with a temporary remission of fever, the patient develops bleeding manifestations such as petechiae, ecchymoses, oozing from puncture sites, melena, hematuria, and gastrointestinal (GI) hemorrhage. Crimean-Congo hemorrhagic fever may cause quite severe ecchymoses and extensive GI bleeding. There is severe headache, lumbar pain, nausea and vomiting, delirium, and prostration. Fatal cases are associated with extensive hemorrhage, coma, and shock. Other common physical findings are epigastric tenderness, modest hepatomegaly, and less frequently icterus.

(b) Mortality among cases recognized as hemorrhagic fever is 15-30%. Convalescence in survivors is prolonged with asthenia, dizziness, and often hair loss. Milder clinical disease occurs in an unknown proportion of infections. There may be geographic variations, possibly related to viral strain differences.

b. *Diagnosis.*

(1) *Differential Diagnosis.* Thrombocytopenia and elevated aspartate aminotransferase (AST) may provide a clue to suggest CCHF in the febrile patient seen early in the course of infection. Other viral hemorrhagic fevers, meningococcemia, rickettsial diseases, and similar conditions may resemble full-blown CCHF. Particular care should be taken in the case of massive GI bleeding not to confuse CCHF with surgical conditions.

(2) *Routine Laboratory Findings.* Leukopenia, thrombocytopenia, and elevated AST are all seen early. Abnormal coagulation tests are common and usually indicate disseminated intravascular coagulation (DIC). Platelets  $\leq 20,000/\text{ml}$ , APT  $\geq 260$  sec, or AST  $\geq 200\text{U}/\text{ml}$  carry a poor prognosis.

(3) *Specific Laboratory Diagnosis.* Most fatal cases and half the others will have detectable antigen by rapid enzyme-linked immunosorbant assay (ELISA) testing of acute serum samples. IgM ELISA antibodies occur early in recovery. IgG ELISA and fluorescent antibodies also show rising titers. Virus isolation in suckling mice is usually successful from acute sera.

c. *Therapy.*

(1) Supportive therapy with replacement of clotting factors is indicated. Crimean-Congo hemorrhagic fever virus is sensitive to ribavirin *in vitro* and clinicians have been favorably impressed in uncontrolled trials. Patients should be treated with intravenous ribavirin (30 mg/kg followed by 15 mg/kg q 6 h for 4 days and 7.5 mg/kg q 8 h for 6 days). Mild reversible anemia may occur. Immune globulin has also been recommended but is available only in Bulgaria.

(2) Because of several well-defined outbreaks within hospitals, protective measures for medical personnel are an issue. The weight of evidence points

to large droplets or fomites as the mediators of transmission and so strict barrier nursing is indicated and probably sufficient for the care of naturally acquired disease. The virus is aerosol-infectious and additional precautions (for example, respirators) might be considered in a biological warfare setting.

d. *Prophylaxis.*

- (1) Although there is little field experience and no definitive data on efficacy, the sensitivity of the virus to ribavirin and the severity of disease suggests that prophylaxis of high-risk exposures is indicated. Persons with percutaneous exposure to contaminated needles or instruments and those exposed directly to fresh blood from CCHF patients should receive 400 mg ribavirin po tid (three times daily) for one day and then continue with 400 mg po tid for 7 days after the last exposure. If more than 48 hours have elapsed after the first such exposure, 30 mg/kg should be given intravenous (IV) followed by three IV doses of 15 mg/kg at 8 hourly intervals; then continue with 400 mg po q 8 hours. If there is GI intolerance, the 400 mg oral dose can be substituted with 180 mg IV. Monitoring for anemia is suggested.
- (2) In the case of a suspected biological attack, ribavirin could be considered for prophylaxis, but there is insufficient information to make a firm recommendation for dosing. Use of 400 mg tid may result in mild to modest anemia in some recipients, GI intolerance in a small proportion, and the drug is embryopathic in rodents; there are unresolved issues of reversible testicular damage in rodents. An inactivated mouse-brain vaccine is used in Bulgaria, but there is no general experience with this product.

**B.08. Melioidosis.**

a. *Clinical Syndrome.*

- (1) *Characteristics.* Melioidosis is an infectious disease of humans and animals caused by *Pseudomonas pseudomallei*, a gram-negative bacillus. It is especially prevalent in Southeast Asia but has been described from many countries around the world. The disease has a variable and inconstant clinical spectrum. A biological warfare attack with this organism would most likely be by the aerosol route.
- (2) *Clinical Features.* Infection by inoculation results in a subcutaneous nodule with acute lymphangitis and regional lymphadenitis, generally with fever. Pneumonia may occur after inhalation or hematogenous dissemination of infection. It may vary in intensity from mild to fulminant, usually involves the upper lobes, and often results in cavitation. Pleural effusions are uncommon. An acute fulminant septicemia may occur characterized by rapid appearance of hypotension and shock. A chronic suppurative form may involve virtually any organ in the body.

b. *Diagnosis.*

- (1) *Routine Laboratory Findings.* The white blood cell count may range from normal to 20,000 per mm<sup>3</sup>, and a mild anemia may develop during the illness.
- (2) *Differential Diagnosis.* Melioidosis should be considered in the differential



diagnosis of any febrile illness, especially if multiple pustular skin or subcutaneous lesions develop, if the illness presents with fulminant respiratory failure, or there is a chest x-ray pattern suggestive of tuberculosis but without acid-fast bacilli on smear.

- (3) *Specific Laboratory Diagnosis.* Microscopic examination of sputum or purulent exudates will reveal small, gram-negative bacilli with bipolar staining using methylene blue or Wright's stain. *P. pseudomallei* can be cultured on routine media and identified by standard bacteriologic procedures. A number of serological tests are useful in diagnosis when they show a fourfold titer rise in paired sera.
- c. *Therapy.* Antibiotic regimens that have been used successfully include tetracycline, 2-3 g/day; chloramphenicol, 3 g/day; and trimethoprim-sulfamethoxazole, 4 and 20 mg/kg per day. Ceftazidime and piperacillin have enjoyed success in severely ill patients as well. In patients who are toxic, a combination of two antibiotics, given parenterally, is advised. Treatment should be continued with oral drugs for 60-150 days, and adjusted based on *in vitro* sensitivity studies of the organism isolated from the patient.
- d. *Prophylaxis.* There are no means of immunization. Vigorous cleansing of abrasions and lacerations may reduce the risk of disease after inoculation of organisms into the skin. There is no information available on the utility of antibiotic prophylaxis after a potential exposure before the onset of clinical symptoms.

## B.09. Plague.

### a. *Clinical Syndrome.*

- (1) *Characteristics.* Plague is a zoonotic disease caused by *Yersinia pestis*. Under natural conditions, humans become infected as a result of contact with rodents, and their fleas. The transmission of the gram-negative coccobacillus is by the bite of the infected flea, *Xenopsylla cheopis*, the oriental rat flea, or *Pulex irritans*, the human flea. Under natural conditions, three syndromes are recognized: bubonic, primary septicemia, or pneumonic. In a biological warfare scenario, the plague bacillus could be delivered via contaminated vectors (fleas) causing the bubonic type or, more likely, via aerosol causing the pneumonic type.
- (2) *Clinical Features.* In bubonic plague, the incubation period ranges from 2 to 10 days. The onset is acute and often fulminant with malaise, high fever, and one or more tender lymph nodes. Inguinal lymphadenitis (bubo) predominates, but cervical and axillary lymph nodes can also be involved. The involved nodes are tender, fluctuant, and necrotic. Bubonic plague may progress spontaneously to the septicemia form with organisms spread to the central nervous system, lungs (producing pneumonic disease), and elsewhere. The mortality is 50 percent in untreated patients with the terminal event being circulatory collapse, hemorrhage, and peripheral thrombosis. In primary pneumonic plague, the incubation period is 2 to 3 days. The onset is acute and fulminant with malaise, high fever, chills, headache, myalgia, cough with

production of a bloody sputum, and toxemia. The pneumonia progresses rapidly, resulting in dyspnea, stridor, and cyanosis. In untreated patients, the mortality is 100 percent with the terminal event being respiratory failure, circulatory collapse, and a bleeding diathesis.

b. *Diagnosis.*

- (1) *Presumptive.* Presumptive diagnosis can be made by identification of the gram-negative coccobacillus with safety-pin bipolar staining organisms in Giemsa or Wayson's stained slides from a lymph node needle aspirate, sputum, or cerebrospinal fluid (CSF) samples. When available, immunofluorescent staining is very useful. Elevated levels of antibody to *Y. pestis* in a nonvaccinated patient may also be useful.
- (2) *Definitive.* *Yersinia pestis* can be readily cultured from blood, sputum, and bubo aspirates. Most naturally occurring strains of *Y. pestis* produce an "F1" antigen *in vivo* which can be detected in serum samples by immunoassay. A fourfold rise of *Y. pestis* antibody levels in patient serum is also diagnostic.
- (3) *Differential.* In cases where bubonic type is suspected, tularemia adenitis, staphylococcal or streptococcal adenitis, meningococemia, enteric gram-negative sepsis, and rickettsiosis need to be ruled out. In pneumonic plague, tularemia, anthrax, and staphylococcal enterotoxin B (SEB) agents need to be considered. Continued deterioration without stabilization effectively rules out SEB. The presence of a widened mediastinum on chest x-ray should alert one to the diagnosis of anthrax.

c. *Therapy.* Plague may be spread from person to person by droplets. Strict isolation procedures for all cases are indicated. Streptomycin, tetracycline, and chloramphenicol are highly effective if begun early. Significant reduction in morbidity and mortality is possible if antibiotics are given within the first 24 hours after symptoms of pneumonic plague develop. Intravenous doxycycline (200 mg initially, followed by 100 mg every 12 hours), intramuscular streptomycin (1 g every 12 hours), or intravenous chloramphenicol (1 g every 6 hours) for 10-14 days are effective against naturally occurring strains. Supportive management of life-threatening complications from the infection, such as shock, hyperpyrexia, convulsions, and disseminated intravascular coagulation (DIC), need to be initiated as they develop.

d. *Prophylaxis.* A formalin-killed *Y. pestis* vaccine is produced in the United States and has been extensively used. Efficacy against flea-borne plague is inferred from population studies, but the utility of this vaccine against aerosol challenge is unknown. Reactogenicity is moderately high and a measurable immune response is usually attained after a 3-dose primary series: at 0, 1, and 4-7 months. To maintain immunity, boosters every 1-2 years are required. Live-attenuated vaccines are available elsewhere but are highly reactogenic and without proven efficacy against aerosol challenge.

## B.10. Q Fever.

### a. *Clinical Syndrome.*

- (1) *Characteristics.* Q fever is a zoonotic disease caused by a rickettsia, *Coxiella burnetii*. The most common animal reservoirs are sheep, cattle and goats. Humans acquire the disease by inhalation of particles contaminated with the organisms. A biological warfare attack would cause disease similar to that occurring naturally.
- (2) *Clinical Features.* Following an incubation period of 10-20 days, Q fever generally occurs as a self-limiting febrile illness lasting 2 days to 2 weeks. Pneumonia occurs frequently, usually manifested only by an abnormal chest x-ray. A nonproductive cough and pleuritic chest pain occur in about one-fourth of patients with Q fever pneumonia. Patients usually recover uneventfully. Uncommon complications include chronic hepatitis, endocarditis, aseptic meningitis, encephalitis, and osteomyelitis.

### b. *Diagnosis.*

- (1) *Routine Laboratory Findings.* The white blood cell count is elevated in one third of patients. Most patients with Q fever have a mild elevation of hepatic transaminase levels.
- (2) *Differential Diagnosis.* Q fever usually presents as an undifferentiated febrile illness, or a primary atypical pneumonia, which must be differentiated from pneumonia caused by mycoplasma, legionnaire's disease, psittacosis or *Chlamydia pneumonia*. More rapidly progressive forms of pneumonia may look like bacterial pneumonias including tularemia or plague.
- (3) *Specific Laboratory Diagnosis.* Identification of organisms by staining sputum is not helpful. Isolation of the organism is difficult and impractical. The diagnosis can be confirmed serologically.

c. *Therapy.* Tetracycline (250 mg every 6 hr) or doxycycline (100 mg every 12 hr) for 5-7 days is the treatment of choice. A combination of erythromycin (500 mg every 6 hr) plus rifampin (600 mg per day) is also effective.

d. *Prophylaxis.* Vaccination with a single dose of a killed suspension of *C. burnetii* provides complete protection against naturally occurring Q fever and >90% protection against experimental aerosol exposure in human volunteers. Protection lasts for at least 5 years. Administration of this vaccine in immune individuals may cause severe cutaneous reactions including necrosis at the inoculation site. Newer vaccines are under development. Treatment with tetracycline during the incubation period will delay but not prevent the onset of illness.

## B. 11. Ricin.

### a. *Clinical Syndrome.*

- (1) *Characteristics.* Ricin is a glycoprotein toxin (66,000 daltons) from the seed of the castor plant. It blocks protein synthesis by altering the rRNA, thus killing the cell. Ricin's significance as a potential biological warfare agent relates to its availability world wide, its ease of production, and extreme

pulmonary toxicity when inhaled.

- (2) *Clinical Features.* Overall, the clinical picture seen depends on the route of exposure. All reported serious or fatal cases of castor bean ingestion have taken approximately the same course: rapid onset of nausea, vomiting, abdominal cramps and severe diarrhea with vascular collapse; death has occurred on the third day or later. Following inhalation, one might expect nonspecific symptoms of weakness, fever, cough, and hypothermia followed by hypotension and cardiovascular collapse. In monkeys, inhalation toxicity is characterized by a dose dependent preclinical period of 24-36 hours followed by anorexia and progressive decrease in physical activity. Death occurs 36-48 hours post challenge. In mice, histopathologic change is characterized by necrotizing, suppurative airways lesions: rhinitis, laryngitis, tracheitis, bronchitis, bronchiolitis, and interstitial pneumonia with perivascular and alveolar edema. Histopathologic change in the airways is seen as early as 3 hours post challenge. The exact cause of death is unknown and probably varies with route of intoxication. High doses by inhalation appear to produce severe enough pulmonary damage to cause death.

b. *Diagnosis.*

- (1) *Routine Laboratory Findings.* Laboratory findings are generally nonspecific. Neutrophilic leukocytosis beginning between 12-18 hours was reported in a case of human lethal intramuscular intoxication that was purposely inflicted. Leukocytosis, beginning 12-18 hours after challenge, also occurs following aerosol exposure of laboratory animals.
- (2) *Differential Diagnosis.* In oral intoxication, fever, gastrointestinal involvement, and vascular collapse are prominent, the latter differentiating it from infection with enteric pathogens. With regard to inhalation exposure, nonspecific findings of weakness, fever, vomiting, cough, hypothermia, and hypotension in large numbers of patients might suggest several respiratory pathogens. The temporal onset of botulinum intoxication would be similar, but include ptosis and general muscular paralysis with minimal pulmonary effects. Staphylococcal enterotoxin B intoxication would likely have a more rapid onset after exposure and a lower mortality rate but could be difficult to distinguish. Nerve agent intoxication is characterized by acute onset of cholinergic crisis with dyspnea and profuse secretions.
- (3) *Specific Laboratory Diagnosis.* Based on animal studies, ELISA (for blood) or immunohistochemical techniques (for direct analysis of tissues) may be useful in confirming ricin intoxication. Postmortem pathologic change is route specific: inhalation results in airways lesions; ingestion causes gastrointestinal hemorrhage with necrosis of liver, spleen, and kidneys; and intramuscular intoxication causes severe local muscle and regional lymph node necrosis with moderate involvement of visceral organs. Ricin is extremely immunogenic; sera should be obtained from survivors for measurement of antibody response.

- c. *Therapy.* Management is supportive and should include maintenance of intravascular volume. Standard management for poison ingestion should be employed if

intoxication is by the oral route. There is presently no antitoxin available for treatment.

- d. *Prophylaxis.* There is currently no prophylaxis approved for human use. Active immunization and passive antibody prophylaxis are under study, as both are effective in protecting animals from death following exposure by intravenous or respiratory routes. Ricin is not dermally active, therefore, respiratory protection is the most critical means of prevention.

## B.12. Rift Valley Fever.

### a. *Clinical Syndrome.*

- (1) *Characteristics.* Rift Valley Fever (RVF) is a viral disease caused by RVF virus. The virus circulates in sub-Saharan Africa as a mosquito-borne agent. Epizootics occur when susceptible domestic animals are infected, and because of the large amount of virus in their serum, amplify infection to biting arthropods. Deaths and abortions among susceptible species such as cattle and sheep constitute a major economic consequence of these epizootics, as well as providing a diagnostic clue and a method of surveillance. Humans become infected by the bite of mosquitoes or by exposure to virus-laden aerosols or droplets. Although disease may occur during an unexceptional rainy season, outbreaks are typically associated with very high densities of arthropod vector populations that may occur during heavy and prolonged rains or in association with irrigation projects. During epidemics the virus may be transmitted by many species of mosquitoes; its potential for introduction into areas with susceptible livestock and dense mosquito populations is believed to be high, as exemplified by a major epidemic in the Nile valley in 1977-79. The human disease appears to be similar whether acquired by aerosol or by mosquito bite. A biological warfare attack, most likely delivered by aerosol, would be expected to elicit the rather specific spectrum of human clinical manifestations and to cause disease in sheep and cattle in the exposed area. If disease occurred in the absence of heavy vector populations or without domestic animals as amplifiers of mosquito infection, a BW attack would also be a likely cause. Domestic animals are probably susceptible to aerosol infection or could be covertly infected to initiate an epidemic which might propagate itself by the usual means.
- (2) *Clinical Features.* The incubation is two to five days and is usually followed by an incapacitating febrile illness of similar duration. The typical physical findings are fever, conjunctival injection, and sometimes abdominal tenderness. A few petechiae or epistaxis may occur. A small proportion of cases (approximately one percent) will progress to a viral hemorrhagic fever syndrome, often with associated hepatitis. These cases may manifest petechiae, mucosal bleeding, icterus, anuria, and shock; mortality in this group is roughly 50 percent. A similar proportion will develop clinically significant ocular changes; macular lesions associated with retinal vasculitis,

hemorrhage, edema, and infarction. Ocular manifestations begin after the patient enters convalescence from acute illness and about half of the patients will have permanent visual defects. A small number of infections will lead to a late encephalitis. After apparent recovery from a typical febrile illness, the patient develops fever, meningeal signs, obtundation, and focal defects. These patients may die or often have serious sequelae.

b. *Diagnosis.*

- (1) *Differential Diagnosis.* The clinical syndrome in an individual is not pathognomonic, but the occurrence of an epidemic with febrile disease, hemorrhagic fever, eye lesions, and encephalitis in different patients would be characteristic of RVF.
- (2) *Routine Laboratory Findings.* In acute uncomplicated disease, there is often a transient leucopenia, but liver and clotting function tests are normal. In hemorrhagic fever, abnormalities of hepatic and coagulation tests are proportional to severity of disease. Disseminated intravascular coagulation may be present. Patients with encephalitis have up to several hundred cells/mm in CSF, predominantly lymphocytes.
- (3) *Specific Laboratory Diagnosis.* Demonstration of viral antigen in blood by ELISA is rapid and successful in a high proportion of acute cases of uncomplicated disease or hemorrhagic fever. IgM antibodies appear with cessation of viremia and are present when ocular or central nervous system (CNS) manifestations are noted. False positive reactions may occasionally be noted in patients with multiple sandfly fever infections. Encephalitis patients have IgM and IgG antibodies in CSF. A proportion of cases should be studied by classical means such as determination of neutralizing antibodies and virus isolation. Wide-scale surveillance is readily accomplished by simultaneous determination of IgG (infection or vaccination at an indeterminate time) and IgM (recent exposure) antibodies in human or domestic animal blood.

c. *Therapy.* In hemorrhagic fever, supportive therapy may be indicated for hepatic and renal failure, as well as replacement of coagulation factors. The virus is sensitive to ribavirin *in vitro* and in rodent models. No studies have been performed in human or the more realistic monkey model to ascertain whether administration to an acutely ill patient would be of benefit. It would be reasonable to treat patients with early signs of hemorrhagic fever with intravenous ribavirin (30 mg/kg followed by 15 mg/kg q 6 hr for 4 days and 7.5 mg/kg q 8 hr for 6 days). This regimen is safe and effective in hemorrhagic fevers caused by some viruses, although a reversible anemia may appear. Therapy may be stopped 2-3 days after improvement begins or antibody appears. Penetration of ribavirin into the CNS is slow and perhaps limited, but in the absence of any other specific therapy, the drug might be used in ocular and encephalitic cases.

d. *Prophylaxis.* Avoidance of mosquitoes and contact with fresh blood from dead domestic animals and respiratory protection from small particle aerosols are the mainstays of prevention. An effective inactivated vaccine is available in limited quantities. The dose is one ml given sc on days 0, 7, and 28; exact timing is not critical. Protective antibodies begin to appear within 10-14 days and last for a year,

at which time a one ml booster should be given. A single injection probably is not protective, but two inoculations may provide marginal short-term protection. Ribavirin prophylaxis (400 mg q 8 hr) of a related sandfly fever virus was successful, but the dose used might be expected to produce anemia and other effects in some recipients. The utility of lower doses has not been determined. Interferon alpha in doses not expected to be reactogenic in humans ( $5 \times 10^3$  -  $5 \times 10^4$  U/kg daily) is preventive in monkeys and might be considered for post-exposure prophylaxis in humans.

### B.13. Saxitoxin.

#### a. *Clinical Syndrome.*

##### (1) *Characteristics.*

(a) Saxitoxin is the parent compound of a family of chemically related neurotoxins. In nature they are predominantly produced by marine dinoflagellates, although they have also been identified in association with such diverse organisms as blue-green algae, crabs, and the blue-ringed octopus. Human intoxications are principally due to ingestion of bivalve molluscs which have accumulated dinoflagellates during filter feeding. The resulting intoxication, known as paralytic shellfish poisoning (PSP), is known throughout the world as a severe, life-threatening illness requiring immediate medical intervention.

(b) Saxitoxin and its derivatives are water-soluble compounds that bind to the voltage-sensitive sodium channel, blocking propagation of nerve-muscle action potentials. Consistent with this mechanism of action, victims typically present with neurological symptoms and in severe cases, death results from respiratory paralysis.

(c) The natural route of exposure to these toxins is oral. In a BW scenario, the most likely route of delivery is by inhalation or toxic projectile. In addition, saxitoxin could be used in a confined area to contaminate water supplies.

(2) *Clinical Features.* After oral exposure, absorption of toxins from the gastrointestinal tract is rapid. Onset of symptoms typically begins 10-60 minutes after exposure, but may be delayed several hours depending upon the dose and individual idiosyncrasy. Initial symptoms are numbness or tingling of the lips, tongue and fingertips, followed by numbness of the neck and extremities and general muscular incoordination. Nausea and vomiting may be present, but typically occur in a minority of cases. Other symptoms may include a feeling of light headedness, or floating, dizziness, weakness, aphasia, incoherence, visual disturbances, memory loss and headache. Cranial nerves are often involved, especially those responsible for ocular movements, speech, and swallowing. Induced reflexes are normal and the patient remains conscious. Respiratory distress and flaccid muscular paralysis are the terminal stages and can occur 2-12 hours after intoxication. Death results from respiratory paralysis. Clearance of the toxin is rapid and

survivors for 12-24 hours will usually recover. Complete recovery may require 7-14 days. There are no known cases of inhalation exposure to saxitoxin in the medical literature, but data from animal experiments suggest the entire syndrome is compressed and death may occur in minutes.

b. *Diagnosis.*

- (1) *Routine Laboratory Findings.* Routine laboratory evaluation is not particularly helpful. Cardiac conduction defects may develop. Elevation of serum creatine kinase levels in some patients has been reported.
- (2) *Differential Diagnosis.* Exposure to tetrodotoxin or the ciguatera toxins can manifest very similar signs and symptoms. Ciguatoxins (by oral exposure) typically demonstrate a much greater degree of gastrointestinal involvement, and can also be differentiated by a history of eating finfish rather than shellfish. Tetrodotoxin intoxication is nearly identical to that caused by the saxitoxins except that hypotension typically plays a greater role in severe intoxication. Differential diagnosis may require toxin detection. Gas chromatographic analysis of food or stomach contents can rule out pesticide exposure.
- (3) *Specific Laboratory Tests.* Diagnosis is confirmed by detection of toxin in the food, water, stomach contents or environmental samples. Saxitoxin, neosaxitoxin, and several other derivatives can be detected by ELISA or by mouse bioassay. Specific toxins can be differentiated by high pressure liquid chromatography (HPLC). The Association of Official Analytical Chemists has adopted an official method for mouse bioassay for the analysis of seafood.

c. *Therapy.* Management is supportive and standard management of poison ingestion should be employed if intoxication is by the oral route. Toxins are rapidly cleared and excreted in the urine, so diuresis may increase elimination. Charcoal hemoperfusion has been advocated, but remains unproven in its utility. Incubation and mechanical respiratory support may be required in severe intoxication. Timely resuscitation would be imperative, albeit very difficult, after inhalation exposure on the battlefield. Specific antitoxin therapy has been successful in animal models, but is untested in humans.

d. *Prophylaxis.* No vaccine against saxitoxin exposure has been developed for human use.

## B.14. Smallpox.

a. *Clinical Syndrome.*

- (1) *Characteristics.* Smallpox virus, an orthopoxvirus with a narrow host range confined to humans, was an important cause of morbidity and mortality in the developing world until recent times. Eradication of the natural disease was completed in 1977 and the last human cases (laboratory infections) occurred in 1978. The virus exists today in only 2 laboratory repositories in the U.S. and Russia. Appearance of human cases outside the laboratory would signal use of the virus as a biological weapon. Under natural conditions, the virus



is transmitted by direct (face-to face) contact with an infected case, by fomites, and occasionally by aerosols. Smallpox virus is highly stable and retains infectivity for long periods outside of the host. A related virus, monkeypox, clinically resembles smallpox and causes sporadic human disease in West and Central Africa.

- (2) *Clinical Features.* The incubation period is typically 12 days (range, 10-17 days). The illness begins with a prodrome lasting 2-3 days, with generalized malaise, fever, rigors, headache, and backache. This is followed by defervescence and the appearance of a typical skin eruption characterized by progression over 7-10 days of lesions through successive stages, from macules to papules to vesicles to pustules. The latter finally form crusts and, upon healing, leave depressed depigmented scars. The distribution of lesions is centrifugal (more numerous on face and extremities than on the trunk). Lesions are in the same stage of development at any point in time. Fever may reappear around the 7th day after onset of rash. The case fatality rate is approximately 35% in unvaccinated individuals. A subset of patients develop a hemorrhagic diathesis with disseminated intravascular coagulopathy and have a poor prognosis. Other complications include arthritis, pneumonia, bacterial superinfection of skin lesions, osteomyelitis, and keratitis. Permanent joint deformities and blindness may follow recovery. Vaccine immunity may prevent or modify illness. Fully immune individuals exposed to the virus by the respiratory route may develop fever, sore throat, and conjunctivitis ("contact fever") lasting several days.

b. *Diagnosis.*

- (1) *Routine Laboratory Findings.* Leukopenia is frequently present in severe cases of smallpox. The differential count shows granulocytopenia and a relative increase in lymphocytes. In the early hemorrhagic form, with onset of bleeding before the eruption, severe thrombocytopenia, global reduction in clotting factors, and circulating antithrombin are present, as well as a marked increase in immature lymphoid cells in the peripheral blood, sometimes mistaken for acute leukemia.
- (2) *Differential Diagnosis.* The eruption of chickenpox (varicella) is typically centripetal in distribution (worse on trunk than face and extremities) and characterized by crops of lesions in different stages on development. Chickenpox papules are soft and superficial, compared to the firm, shotty, and deep papules of smallpox. Chickenpox crusts fall off rapidly and usually leave no scar. Monkeypox cannot be easily distinguished from smallpox clinically, although generalized lymphadenopathy is a more common feature of the disease. Monkeypox occurs only in forested areas of West and Central Africa as a sporadic, zoonotic infection transmitted to humans from wild squirrels. Person-to-person spread is rare and ceases after 1-2 generations. Mortality is 15%. Other diseases that are sometimes confused with smallpox include typhus, secondary syphilis, and malignant measles.
- (3) *Specific Laboratory Diagnosis.* Skin samples (scrapings from papules,

vesicular fluid, pus, or scabs) may provide a rapid identification of smallpox by direct electron microscopy, agar gel immunoprecipitation, or immunofluorescence. Virus may be recovered from these samples or blood by inoculation of eggs or cell cultures, but culture techniques require several days. Serological tests may be useful for confirmation, or early presumptive diagnosis.

c. *Therapy.* There is no specific treatment available although some evidence suggests that vaccinia-immune globulin may be of some value in treatment if given early in the course of the illness. The antiviral drug, n-methylisatin  $\beta$ -thiosemicarbazone (Marboran<sup>®</sup>) is not thought to be of any therapeutic value.

d. *Prophylaxis.*

(1) *Vaccines.*

(a) Vaccinia virus is a live poxvirus vaccine that induces strong cross-protection against smallpox for at least 5 years and partial protection for 10 years or more. The vaccine is administered by dermal scarification or intradermal jet injection; appearance of a vesicle or pustule within several days is indication of a "take." Contraindications to vaccination are pregnancy, clinical immunosuppression, eczema, or leukemia/lymphoma. Complications are infrequent, but include: 1) progressive vaccinia in immunosuppressed individuals (case-fatality >75%); 2) eczema vaccinatum in persons with eczema or a history of eczema, or in contacts with eczema (case-fatality 10-15%); 3) postvaccinal encephalitis, almost exclusively seen after primary vaccination, occurring at an incidence of about 1/500,000, with a case-fatality rate of 25%; 4) generalized vaccinia, seen in immunocompetent individuals and having a good prognosis; and 5) autoinoculation of the eye or genital area, with a secondary lesion.

(b) Vaccinia-immune human globulin at a dose of 0.3 mg/kg body weight provides  $\geq 70\%$  protection against naturally occurring smallpox if given during the early incubation period. Administration immediately after or within the first 24 hours of exposure would provide the highest level of protection, especially in unvaccinated persons.

(c) If vaccinia-immune globulin is unavailable, vaccination or revaccination should be performed as early as possible after (and within 24 hours of) exposure, with careful surveillance for signs of illness.

(2) *Antiviral Drug.* The antiviral drug, n-methylisatin  $\beta$ -thiosemicarbazone (Marboran<sup>®</sup>) afforded protection in some early trials, but not others, possibly because of noncompliance due to unpleasant gastrointestinal side effects. Critical review of the published literature suggests a possible protective effect among unvaccinated contacts of naturally infected individuals.

(3) *Quarantine, Disinfection.* Patients with smallpox should be treated by vaccinated personnel using universal precautions. Objects in contact with the patient, including bed linens, clothing, ambulance, etc.; require disinfection by fire, steam, or sodium hypochlorite solution.

## B.15. Staphylococcal Enterotoxin B.

### a. *Clinical Syndrome.*

- (1) *Characteristics.* Staphylococcal Enterotoxin B (SEB) is one of several exotoxins produced by *Staphylococcus aureus*, causing food poisoning when ingested. A BW attack with aerosol delivery of SEB to the respiratory tract produces a distinct syndrome causing significant morbidity and potential mortality.
- (2) *Clinical Features.* The disease begins 1-6 hours after exposure with the sudden onset of fever, chills, headache, myalgia, and nonproductive cough. In more severe cases, dyspnea and retrosternal chest pain may also be present. Fever, which may reach 103-106° F, has lasted 2-5 days, but cough may persist 1-4 weeks. In many patients nausea, vomiting, and diarrhea will also occur. Physical findings are often unremarkable. Conjunctival injection may be present, and in the most severe cases, signs of pulmonary edema would be expected. The chest x-ray is generally normal, but in severe cases, there will be increased interstitial markings, atelectasis, and possibly overt pulmonary edema. In moderately severe laboratory exposures, lost duty time has been < 2 weeks, but, based upon animal data, it is anticipated that severe exposures will result in fatalities.

### b. *Diagnosis.*

- (1) *Routine Laboratory Findings.* Laboratory findings are noncontributory except for a neutrophilic leukocytosis and elevated erythrocyte sedimentation rate.
- (2) *Differential Diagnosis.*
  - (a) In foodborne SEB intoxication, fever and respiratory involvement are not seen, and gastrointestinal symptoms are prominent. The nonspecific findings of fever, nonproductive cough, myalgia, and headache occurring in large numbers of patients in an epidemic setting would suggest any of several infectious respiratory pathogens, particularly influenza, adenovirus, or mycoplasma. In a BW attack with SEB, cases would likely have their onset within a single day, while naturally occurring outbreaks would present over a more prolonged interval. Naturally occurring outbreaks of Q fever and tularemia might cause confusion, but would involve much smaller numbers of individuals, and would more likely be accompanied by pulmonary infiltrates.
  - (b) The dyspnea of botulism is associated with obvious signs of muscular paralysis: its cholinergic blocking effects result in a dry respiratory tree, and patients are afebrile. Inhalation of nerve agent will lead to weakness, dyspnea, and copious secretions. The early clinical manifestations of inhalation anthrax, tularemia, or plague may be similar to those of SEB. However, rapid progression of respiratory signs and symptoms to a stable state distinguishes SEB intoxication. Mustard exposure would have marked vesication of the skin in addition to the pulmonary injury.
- (3) *Specific Laboratory Diagnosis.* Toxin is cleared from the serum rapidly and

is difficult to detect by the time of symptom onset. Nevertheless, specific laboratory tests are available to detect SEB, and serum should be collected as early as possible after exposure. In situations where many individuals are symptomatic, sera should be obtained from those not yet showing evidence of clinical disease. Most patients develop a significant antibody response, but this may require 2-4 weeks.

- c. *Therapy.* Treatment is limited to supportive care. No specific antitoxin for human use is available.
- d. *Prophylaxis.* There currently is no prophylaxis for SEB intoxication. Experimental immunization has protected monkeys, but no vaccine is presently available for human use.

## B.16. Trichothecene Mycotoxins.

### a. *Clinical Syndrome.*

#### (1) *Characteristics.*

(a) The trichothecene mycotoxins are a diverse group of more than 40 compounds produced by fungi. They are potent inhibitors of protein synthesis, impair DNA synthesis, alter cell membrane structure and function, and inhibit mitochondrial respiration. Secondary metabolites of fungi, such as T-2 toxin and others, produce toxic reactions called mycotoxicoses upon inhalation or consumption of contaminated food products by humans or animals. Naturally occurring trichothecenes have been identified in agricultural products and have been implicated in a disease of animals known as moldy corn toxicosis or poisoning.

(b) There are no well-documented cases of clinical exposure of humans to trichothecenes. However, strong circumstantial evidence has associated these toxins with alimentary toxic aleukia (ATA), the fatal epidemic seen in Russia during World War II, and with alleged BW incidents ("yellow rain") in Cambodia, Laos and Afghanistan.

#### (2) *Clinical Features.*

(a) Consumption of these mycotoxins results in weight loss, vomiting, skin inflammation, bloody diarrhea, diffuse hemorrhage, and possibly death. Clinical signs in experimental animals (calves) given 0.08-0.64 mg T-2/kg/day for nine days included loss of appetite, weight loss, an increase in prothrombin time, and an increased serum aspartate amino transferase level. The onset of illness following acute exposure to T-2 (IV or inhalation) occurs in hours, resulting in the rapid onset of circulatory shock characterized by reduced cardiac output, arterial hypotension, lactic acidosis and death within 12 hours.

(b) Clinical signs and symptoms of ATA were hemorrhage, leukopenia, ulcerative pharyngitis, and depletion of bone marrow. The purported use of T-2 as a BW agent resulted in an acute exposure via inhalation and/or dermal routes, as well as oral exposure upon consumption of contaminated food products and water. Alleged victims reported painful skin lesions,

lightheadedness, dyspnea, and a rapid onset of hemorrhage, incapacitation and death. Survivors developed a radiation-like sickness including fever, nausea, vomiting, diarrhea, leukopenia, bleeding, and sepsis.

b. *Diagnosis.*

- (1) *Routine Laboratory Findings.* Hematological alterations in the rodent model (parenteral routes) include marked but transient leukocytosis, characterized by rapid lymphocytosis and a mild neutrophilia. This is followed by a leukopenia that returns to normal values 4-7 days post-exposure. There is a reduced hematocrit with the presence of nucleated erythrocytes. Serum proteins and enzymes are not significantly altered after this acute exposure.
- (2) *Differential Diagnosis.* Other diagnoses to consider include radiation toxicity and plant or chemical toxicity.
- (3) *Specific Laboratory Diagnosis.* Specific diagnostic modalities are limited to reference laboratories. Gas-liquid chromatography (GC) and high pressure liquid chromatography (HPLC) have been used for detecting T-2 and related trichothecene mycotoxins in plasma and urine. Polyclonal and monoclonal antibodies to trichothecenes are also available for detection in liquid or solid samples after solvent extraction. Because of their long "half-life" the toxin metabolizes can be detected as late as 28 days after exposure. Between 50-75% of the parent toxin and metabolizes are eliminated in urine and feces within 24 hours. Urine should be the biological fluid chosen for diagnostic purposes. A one time urine sample with 0.10CC concentrated hydrochloric acid (HCl) added per 100cc of urine, to kill unwanted bacteria, should be submitted for analysis if the exposure was a recent one. Trichothecene mycotoxins can be detected in the urine out to approximately 14 days after exposure but if several days have elapsed since exposure, a 24 hour urine collection with HCl added should be submitted instead of a one time collection. The urine does not need to be kept refrigerated.

c. *Therapy.* General supportive measures are used to alleviate acute T-2 toxicoses. Prompt (within 5-60 min of exposure) soap and water wash significantly reduces the development of the localized destructive, cutaneous effects of the toxin. After oral exposure management should include standard therapy for poison ingestion. Of note is a superactivated charcoal (such as Superchar™, Gulf Bio Systems, Inc., Dallas, TX). Superchar™ oral may offer an advantage over regular activated charcoal in that one needs to see approximately five times the dose of activated charcoal to gain an equivalent outcome to that if Superchar™ is used. Superactivated charcoal is becoming standard in emergency management of poison ingestion. This substance has an extremely large surface area, two to three times that of regular activated charcoal. Superchar™ oral treatment (1-7 g/kg, po) either immediately or 1 to 3 hours after toxin exposure significantly increases survival times of animals. Some benefit may be derived from giving activated charcoal as late as 5 hours after exposure to T-2 toxins. In animal studies, dexamethasone (1-10 mg/kg, IV) administered as late as 3 hours after exposure to T-2 toxin improved survival and reduced the incidence of massive bloody diarrhea. No antitoxin is presently available for human use.

- d. *Prophylaxis.* Ascorbic acid (400-1200 mg/kg, inter-peritoneal (ip)) works to decrease lethality in animal studies, but has not been tested in humans. While not yet available for humans, administration of large doses of monoclonal antibodies directed against T-2 and metabolizes have shown prophylactic and therapeutic efficacy in animal models.

## B.17. Tularemia.

### a. *Clinical Syndrome.*

- (1) *Characteristics.* Tularemia is a zoonotic disease caused by *Francisella tularensis*, a gram-negative bacillus. Humans acquire the disease under natural conditions through inoculation of skin or mucous membranes with blood or tissue fluids of infected animals, or bites of infected deerflies, mosquitoes, or ticks. Less commonly, inhalation of contaminated dusts or ingestion of contaminated foods or water may produce clinical disease. A BW attack with *F. tularensis* delivered by aerosol would primarily cause typhoidal tularemia, a syndrome expected to have a case fatality rate which may be higher than the 5-10% seen when disease is acquired naturally.

(2) *Clinical Features.*

(a) A variety of clinical forms of tularemia are seen, depending upon the route of inoculation and virulence of the strain. In humans, as few as 10-50 organisms will cause disease if inhaled or injected intradermally, whereas 10<sup>8</sup> organisms are required with oral challenge. Under natural conditions, ulceroglandular tularemia generally occurs about 3 days after intradermal inoculation (range 2-10 days), and manifests as regional lymphadenopathy, fever, chills, headache, and malaise, with or without a cutaneous ulcer. In those 5-10% of cases with no visible ulcer, the syndrome may be known as glandular tularemia. Primary ulceroglandular disease confined to the throat is referred to as pharyngeal tularemia. Oculoglandular tularemia occurs after inoculation of the conjunctival with a hand or fingers contaminated by tissue fluids from an infected animal. Gastrointestinal tularemia occurs after drinking contaminated ground water, and is characterized by abdominal pain, nausea, vomiting, and diarrhea.

(b) Bacteremia probably is common after primary intradermal, respiratory, or gastrointestinal infection with *F. tularensis* and may result in septicemia or "typhoidal" tularemia. The typhoidal form also may occur as a primary condition in 5-15% of naturally-occurring cases; clinical features include fever, prostration, and weight loss, but without adenopathy. Diagnosis of primary typhoidal tularemia is difficult, as signs and symptoms are non-specific and there frequently is no suggestive exposure history. Pneumonic tularemia is a severe atypical pneumonia that may be fulminant, and can be primary or secondary. Primary pneumonia may follow direct inhalation of infectious aerosols, or may result from aspiration of organisms in cases of pharyngeal tularemia. Pneumonic tularemia causes fever, headache, malaise, substernal discomfort, and a non-productive cough; radiologic evidence of

pneumonia or mediastinal lymphadenopathy may or may not be present.

(c) A biological warfare attack with *F. tularensis* would most likely be delivered by aerosol, causing primarily typhoidal tularemia. Many exposed individuals would develop pneumonic tularemia (primary or secondary), but clinical pneumonia may be absent or non-evident. Case fatality rates may be higher than the 5-10% seen when the disease is acquired naturally.

b. *Diagnosis.*

(1) *Differential Diagnosis.* The clinical presentation of tularemia may be severe, yet nonspecific. Differential diagnoses include typhoidal syndromes (e.g., salmonella, rickettsia, malaria) or pneumonic processes (e.g., plague, mycoplasma, SEB). A clue to the diagnosis of tularemia delivered as a BW agent might be a large number of temporally clustered patients presenting with similar systemic illnesses, a proportion of whom will have a nonproductive pneumonia.

(2) *Specific Laboratory Diagnosis.* Identification of organisms by staining ulcer fluids or sputum is generally not helpful. Routine culture is difficult, due to unusual growth requirements and/or overgrowth of commensal bacteria. The diagnosis can be established retrospectively by serology.

c. *Therapy.* Streptomycin (1 gm q 12 intramuscular (IM) for 10-14 days) is the treatment of choice. Gentamicin also is effective (3-5 mg/kg/day parenterally for 10-14 days). Tetracycline and chloramphenicol treatment are effective as well, but are associated with a significant relapse rate. Although laboratory-related infections with this organism are very common, human-to-human spread is unusual and isolation is not required.

d. *Prophylaxis.* A live, attenuated tularemia vaccine is available as an investigational new drug (IND). This vaccine has been administered to more than 5,000 persons without significant adverse reactions and is of proven effectiveness in preventing laboratory-acquired typhoidal tularemia. Its effectiveness against the concentrated bacterial challenge expected in a BW attack is unproven. The use of antibiotics for prophylaxis against tularemia is controversial.

## B.18. Venezuelan Equine Encephalitis.

a. *Clinical Syndrome.*

(1) *Characteristics.* Eight serologically distinct viruses belonging to the Venezuelan equine encephalitis (VEE) complex have been associated with human disease; the most important of these pathogens are designated subtype 1, variants A, B and C. These agents also cause severe disease in horses, mules, and donkeys (Equidae). Natural infections are acquired by the bites of a wide variety of mosquitoes; Equidae serve as the viremic hosts and source of mosquito infection. In natural human epidemics, severe and often fatal encephalitis in Equidae always precedes that in humans. A BW attack with virus disseminated as an aerosol would cause human disease as a primary event. If Equidae were present, disease in these animals would occur

simultaneously with human disease. Secondary spread by person-to-person contact occurs at a negligible rate. However, a BW attack in a region populated by Equidae and appropriate mosquito vectors could initiate an epizootic/epidemic.

- (2) *Clinical Features.* Nearly 100% of those infected suffer an overt illness. After an incubation period of 1-5 days, onset of illness is extremely sudden, with generalized malaise, spiking fever, rigors, severe headache, photophobia, myalgia in the legs and lumbosacral area. Nausea, vomiting, cough, sore throat, and diarrhea may follow. This acute phase lasts 24-72 hours. A prolonged period of aesthenia and lethargy may follow, with full health and activity regained only after 1-2 weeks. Approximately 470 of patients during natural epidemics develop signs of central nervous system infection, with meningismus, convulsions, coma, and paralysis. These neurologic cases are seen almost exclusively in children. The overall case-fatality rate is < 1%, but in children with encephalitis, it may reach 20%. Permanent neurological sequelae are reported in survivors. Aerosol infection does not appear to increase the likelihood of CNS disease. A VEE infection during pregnancy may cause encephalitis in the fetus, placental damage, abortion, or severe congenital neuroanatomical anomalies.

b. *Diagnosis.*

- (1) *Routine Laboratory Findings.* The white blood cell count shows a striking leukopenia and lymphopenia. In cases with encephalitis, the cerebrospinal fluid may be under increased pressure and contain up to 1000 white cells/mm<sup>3</sup> (predominantly mononuclear cells) and mildly elevated protein concentration.
- (2) *Differential Diagnosis.* An outbreak of VEE may be difficult to distinguish from influenza on clinical grounds. Clues to the diagnosis are the appearance of a small proportion of neurological cases or disease in Equidae, but these might be absent in a BW attack.
- (3) *Specific Laboratory Diagnosis.* Viremia during the acute phase of illness is generally high enough to allow detection by antigen-capture enzyme immunoassay. Virus isolation may be made from serum, and in some cases throat swab specimens, by inoculation of cell cultures. A variety of serological tests are applicable, including the IgM ELISA, indirect fluorescent assay (FA), hemagglutination inhibition, complement-fixation, and neutralization. For persons without prior exposure to VEE complex viruses in tropical areas, a presumptive diagnosis may be made by finding antibodies in a single serum sample taken 5-7 days after onset of illness.

- c. *Therapy.* There is no specific therapy. Patients with uncomplicated VEE infection may be treated with analgesics to relieve headache and myalgia. Patients who develop encephalitis may require anticonvulsant and intensive supportive care to maintain fluid and electrolyte balance, adequate ventilation, and to avoid complicating secondary bacterial infections.



d. *Prophylaxis.*

(1) *Vaccine.*

(a) An experimental vaccine, designated TC-83 is a live, attenuated cell-culture-propagated vaccine which has been used in several thousand persons to prevent laboratory infections. The vaccine is given as a single 0.5 ml subcutaneous dose. Febrile reactions occur in up to 18% of persons vaccinated, and may be moderate-to-severe in 5%, with fever, myalgia, headache, and prostration. Approximately 10% of vaccinees fail to develop detectable neutralizing antibodies, but it is unknown whether they are susceptible to clinical infection if challenged. Nonresponders may be revaccinated with TC-83. Contraindications for use include an intercurrent viral infection or pregnancy. TC-83 is a licensed vaccine for Equidae.

(b) A second investigational product that has been tested in humans is the C-84 vaccine, prepared by formalin-inactivation of the TC-83 strain. The vaccine is presently not recommended for primary immunization, on the basis of animal studies indicating that it may not protect against aerosol infection. However, it may be useful for aerosol protection for persons not responding to TC-83 (0.5 ml subcutaneously at 2 to 4 week intervals for up to 3 inoculations or until an antibody response is measured.)

(2) *Antiviral Drugs.* In experimental animals, alpha-interferon and the interferon-inducer poly-ICLC (lysine-polyadenosine) have proven highly effective for post-exposure prophylaxis of VEE. There are no clinical data on which to assess efficacy in humans.

**NATO HANDBOOK ON MEDICAL ASPECTS  
OF NBC DEFENSIVE OPERATIONS  
AMedP-6(B)**

**PART II - BIOLOGICAL**

**ANNEX C**

**POTENTIAL BIOLOGICAL AGENTS OPERATIONAL DATA CHARTS**

**1 FEBRUARY 1996**

**TABLE OF CONTENTS**

			<b>Page</b>
Table	C-I	Bacteria	C-3
	C-II.	Rickettsiae	C-4
	C-III.	Chlamydia	C-5
	C-IV.	Viruses	C-6
	C-V.	Toxins	C-7

THIS PAGE HAS BEEN LEFT INTENTIONALLY BLANK

ANNEX C

POTENTIAL BIOLOGICAL AGENTS OPERATIONAL DATA CHARTS

Table C-1. Bacteria

Serial	Disease	Likely methods of dissemination	Transmissibility man to man	Infectivity	Incubation* time	Duration of illness	Lethality	Persistence	Vaccination	Antimicrobial therapy	Antisera
a	b	c	d	e	f	g	h	i	j	k	l
1	(Inhalation) Anthrax	Spores in aerosols	No	Moderate	1-6 days	3-5 days	High	Spores are highly stable	Yes	Little effect	Experimental
2	Brucellosis	1. Aerosol 2. Sabotage (food supply)	No	High	Days to months	Weeks to years	Low	Long persistence in wet soil & food	Yes	Moderately effective	No
3	Cholera	1. Sabotage (food/water supply) 2. Aerosol	Negligible	Low	1-5 days	1 or more weeks	Moderate to high	Unstable in aerosols & pure water More so in polluted water	Yes	Moderately effective	No
4	Melioidosis	Aerosol	Negligible	High	Days to years	4-20 days	Variable	Stable	None	Moderately effective	No
5	(Pneumonic) Plague	1. Aerosol 2. Infected vectors	High	High	2-3 days	1-2 days	Very high	Less important because of high transmissibility	Yes	Moderately effective	No
6	Tularemia	Aerosol	No	High	2-10 days	2 or more weeks	Moderate if untreated	Not very stable	Yes	Effective	No
7	Typhoid Fever	1. Sabotage (food/water supply) 2. Aerosol	Negligible	Moderate	7-21 days	Several weeks	Moderate if untreated		Yes	Moderately effective	No

\* Incubation applies to infectious disease. With toxins, it's application refers to the period between exposure and appearance of the symptoms and signs of poisoning.

Table C-II. *Rickettsiae*

Serial	Disease	Likely methods of dissemination	Transmissibility man to man	Infectivity	Incubation* time	Duration of illness	Lethality	Persistence	Vaccination	Antimi-crobial therapy	Antisera
a	b	c	d	e	f	g	h	i	j	k	l
8	Epidemic Typhus	1. Aerosol 2. Infected vectors	No	High	6-16 days	Weeks to months	High	Not very stable	No	Effective	No
9	Q-Fever	1. Aerosol 2. Sabotage (food supply)	No	High	10-20 days	2 days to 2 weeks	Very low	Stable	Yes	Effective	No
10	Rocky Mountain Spotted Fever	1. Aerosol 2. Infected vectors	No	High	3-10 days	2 weeks to months	High	Not very stable	No	Effective	No
11	Scrub Typhus	1. Aerosol 2. Infected vectors	No	High	4-15 days	Up to 16 days	Low	Not very stable	No	Effective	No

\* Incubation applies to infectious disease. With toxins, it's application refers to the period between exposure and appearance of the symptoms and signs of poisoning.

Table C-III. Chlamydia

Serial	Disease	Likely methods of dissemination	Transmissibility man to man	Infectivity	Incubation* time	Duration of illness	Lethality	Persistence	Vaccination	Antimi-crobal therapy	Antisera
a	b	c	d	e	f	g	h	i	j	k	l
12	Psittacosis	Aerosol	Negligible	Moderate	4-15 days	Weeks to months	Very low	Stable	No	Effective	No
13	Coccidioido-mycosis	Aerosol	No	High	1-2 weeks	Weeks to months	Low	Stable	No	Not very effective	No
14	Histoplas-mosis	Aerosol	No	High	1-2 weeks	Weeks to months	Low	Long persis-tence in soil	No	Not very effective	No

\* Incubation applies to infectious disease. With toxins, it's application refers to the period between exposure and appearance of the symptoms and signs of poisoning.

Table C-IV. Viruses

Serial	Disease	Likely methods of dissemination			Transmissibility man to man	Infectivity	Incubation* time	Duration of illness	Lethality	Persistence	Vaccination		Antimicrobial therapy		Antisera
		a	b	c							d	e	f	g	
15	Chikungunya Fever	Aerosol	None	High	2-6 days	2 weeks	Very low	Relatively stable	Experimental	Not effective	No				
16	Crimean-Congo Hemorrhagic Fever	Aerosol	Moderate	High	3-12 days	Days to weeks	High	Relatively stable	Experimental (Bulgaria)	Effective	Yes (Bulgaria only)				
17	Dengue Fever	Aerosol	None	High	3-6 days	Days to weeks	Low	Relatively unstable	Experimental	Not effective	No				
18	Eastern Equine Encephalitis	Aerosol	None	High	5-15 days	1-3 weeks	High	Relatively unstable	Yes	Not effective	No				
19	Ebola Fever	Aerosol	Moderate	High	7-9 days	5-16 days	High	Relatively unstable	No	Not effective	No				
20	Korean Hemorrhagic Fever (hantaan)	Aerosol	None	High	4-42 days	Days to weeks	Moderate	Relatively stable	Experimental	Effective	No				
21	Lassa Fever	Aerosol	Low to moderate	High	10-14 days	1-4 weeks	Unknown	Relatively stable	No	Effective	Experimental				
22	Omsk Hemorrhagic Fever	1. Aerosol 2. Water	Negligible	High	3-7 days	7-10 days	Low	Relatively unstable	Experimental	Not effective	No				
23	Rift Valley Fever	1. Aerosol 2. Infected vectors	Low	High	2-5 days	Days to weeks	Low	Relatively stable	Yes	Effective	No				
24	Russian Spring-Summer Encephalitis	1. Aerosol 2. Milk	None	High	8-14 days	Days to months	Moderate	Relatively unstable	Yes	Not effective	Yes				
25	Smallpox	Aerosol	High	High	10-17 days	1-2 weeks	High	Stable	Yes	Not effective	Yes				
26	Western Equine Encephalitis	Aerosol	No	High	1-20 days	1-3 weeks	Low	Relatively unstable	Yes	Not effective	No				
27	Venezuelan Equine Encephalitis	1. Aerosol 2. Infected vectors	Low	High	1-5 days	Days to weeks	Low	Relatively unstable	Yes	Not effective	No				
28	Yellow Fever	Aerosol	None	High	3-6 days	1-2 weeks	High	Relatively unstable	Yes	Not effective	No				

\* Incubation applies to infectious disease. With toxins, it's application refers to the period between exposure and appearance of the symptoms and signs of poisoning.



Table C-V. Toxins

Serial	Disease	Likely methods of dissemination		Transmissibility man to man	Infectivity	Incubation* time	Duration of illness	Lethality	Persistence	Vaccination	Antimi-crobal therapy	Antisera
		c	d									
29	Botulinum Toxin	1. Sabotage (food/water supply) 2. Aerosol	No	No	Variable (hours to days)	24-72 hours Months if lethal	High	Stable	Stable	Yes	Not effective	Yes
30	Clostridium Perfringens Toxins	1. Sabotage 2. Aerosol	No	No	8-12 hours	24 hours	Low	Stable	Stable	No	Not effective	No
31	Trichothecene Mycotoxins	1. Aerosol 2. Sabotage	No	No	Hours	Hours	High	Stable	Stable	No	Not effective	No
32	Palytoxin	1. Aerosol 2. Sabotage	No	No	Minutes	Minutes	High	Stable	Stable	No	Not effective	No
33	Ricin	Aerosol	No	No	Hours	Days	High	Stable	Stable	Under development	Not effective	No
34	Saxitoxin	1. Sabotage 2. Aerosol	No	No	Minutes to hours	Minutes to days	High	Stable	Stable	No	Not effective	No
35	Staphylococcal enterotoxin B	1. Aerosol 2. Sabotage	No	No	1-6 hours	Days to weeks	Low	Stable	Stable	Under development	Not effective	No
36	Tetrodotoxin	1. Sabotage 2. Aerosol	No	No	Minutes to hours	Minutes to days	High	Stable	Stable	No	Not effective	No

\* Incubation applies to infectious disease. With toxins, it's application refers to the period between exposure and appearance of the symptoms and signs of poisoning.

**NATO HANDBOOK ON MEDICAL ASPECTS  
OF NBC DEFENSIVE OPERATIONS  
AMedP-6(B)**

**PART II - BIOLOGICAL**

**ANNEX D**

**PATIENT MANAGEMENT CHARTS**

**1 FEBRUARY 1996**

**TABLE OF CONTENTS**

	Page
Figure	
D-I. Model for an Approach to the Acutely Ill Febrile Patient (Example from the Middle East) (1 of 6)	D-4
Model for an Approach to the Acutely Ill Febrile Patient (Example from the Middle East) (2 of 6)	D-5
Model for an Approach to the Acutely Ill Febrile Patient (Example from the Middle East) (3 of 6)	D-6
Model for an Approach to the Acutely Ill Febrile Patient (Example from the Middle East) (4 of 6)	D-7
Model for an Approach to the Acutely Ill Febrile Patient (Example from the Middle East) (5 of 6)	D-8
Model for an Approach to the Acutely Ill Febrile Patient (Example from the Middle East) (6 of 6)	D-9
Table	
D-I. Differentiation Among Botulinum, Nerve Agent, and Atropine Intoxications	D-3
D-II. An Approach to Potential BW Agents by Predominant Clinical Finding or Syndrome	D-10

THIS PAGE HAS BEEN LEFT INTENTIONALLY BLANK

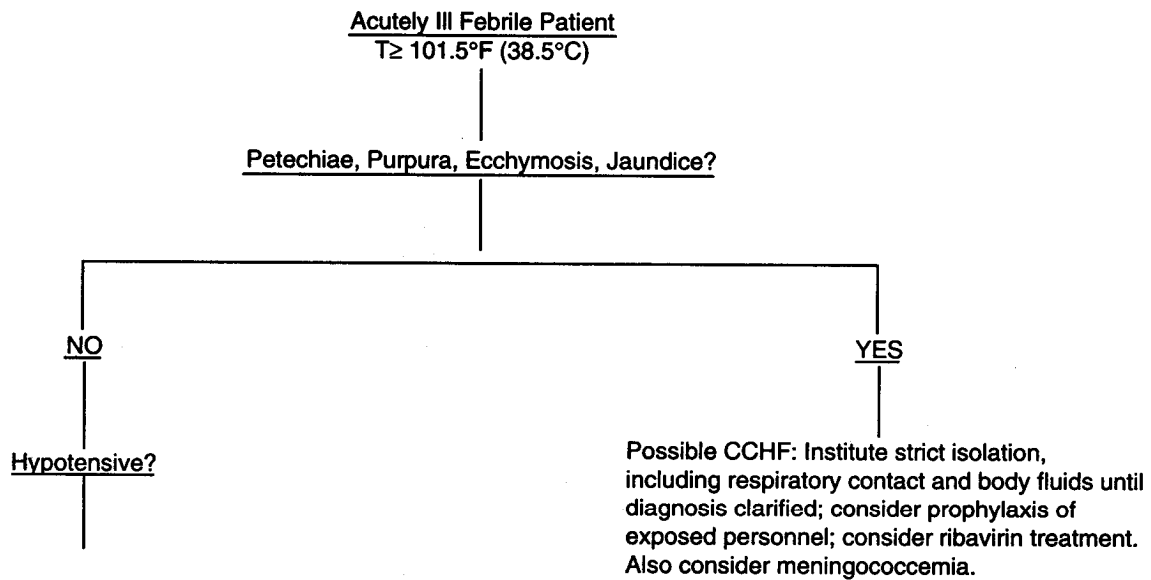
ANNEX D

PATIENT MANAGEMENT CHARTS

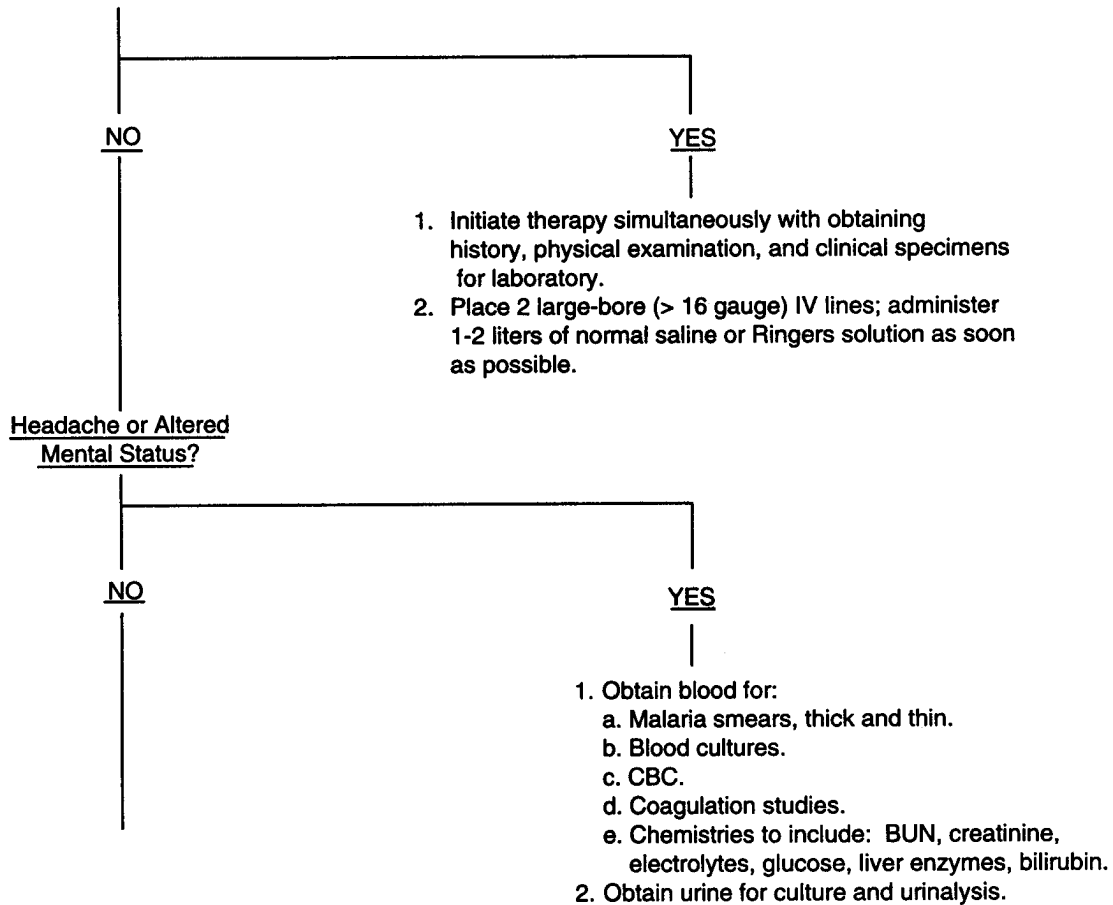
*Table D-I. Differentiation Among Botulinum, Nerve Agent, and Atropine Intoxications*

Item	Botulinum toxin	Nerve agent	Atropine
Sensorium	Usually normal.	Disorientation, agitation, coma, seizures.	Disorientation, excitation, agitation, irritability, coma.
Ocular abnormalities	Dilated and fixed pupils, distorted blurred vision, ptosis, extraocular muscle paralysis.	Constricted pupils, dim vision (if vapor or aerosol exposure), little if any change if exposed via skin.	Weak effects if usual doses given causing pupillary dilation and paralysis of accommodation.
Paralysis	Flaccid paralysis. Early bulbar signs (dysphonia dysphagia) descending to upper and lower extremities. Respiratory failure.	Rigid paralysis with twitching, jerking. Seizures.	None of significance.
Autonomic findings	Dry mouth and skin, constipation, ileus, urinary retention. Early emesis and diarrhea after food ingestion.	Excess salivation, increased sweating, involuntary defecation and urination. Severe rhinorrhea and bronchoconstriction occur if exposure is by inhalation.	Dry mouth and skin, constipation, ileus, urinary retention. Early emesis and diarrhea after food ingestion.
Onset	24-36 hours by inhalation exposure. Not absorbed through intact skin; 12-72 hours onset by oral exposure.	1-10 minutes by inhalation exposure; 1-2 hours by dermal exposure.	Minutes after injection, can be exacerbated by dehydration and heat exposure.

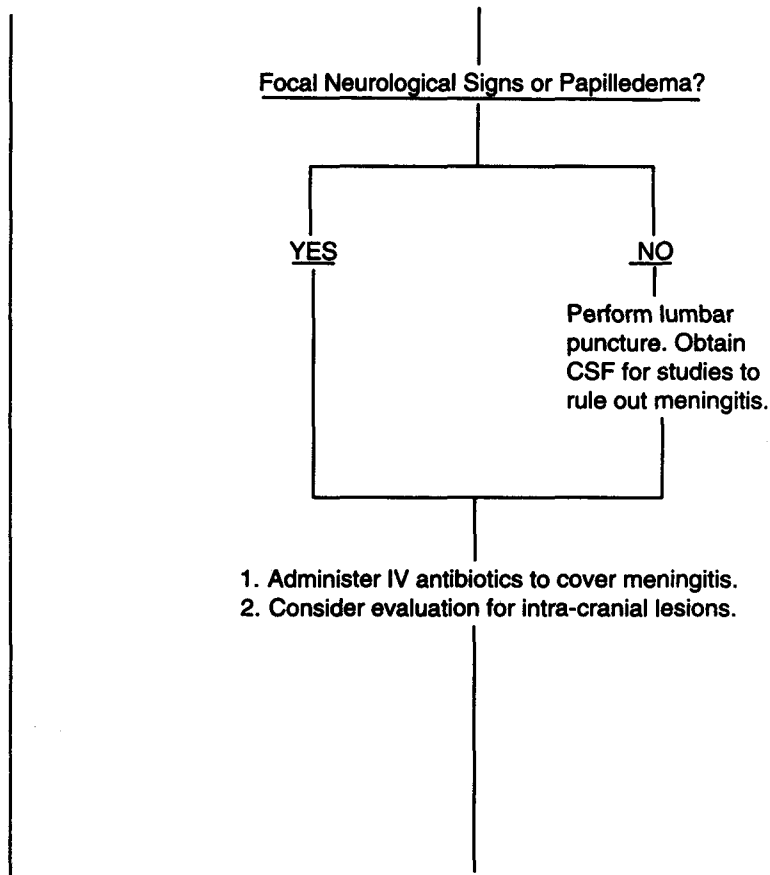
A number of infectious diseases may be rapidly fatal if specific therapy is not immediately instituted. Crimean-Congo hemorrhagic fever may be readily transmitted to hospital personnel, with lethal consequences. The following algorithm (Figure D-I) is designed to prevent lethal oversight in the initial management of acutely ill febrile patients.



*Figure D-I. Model for an Approach to the Acutely Ill Febrile Patient  
(Example from the Middle East) (1 of 6)*

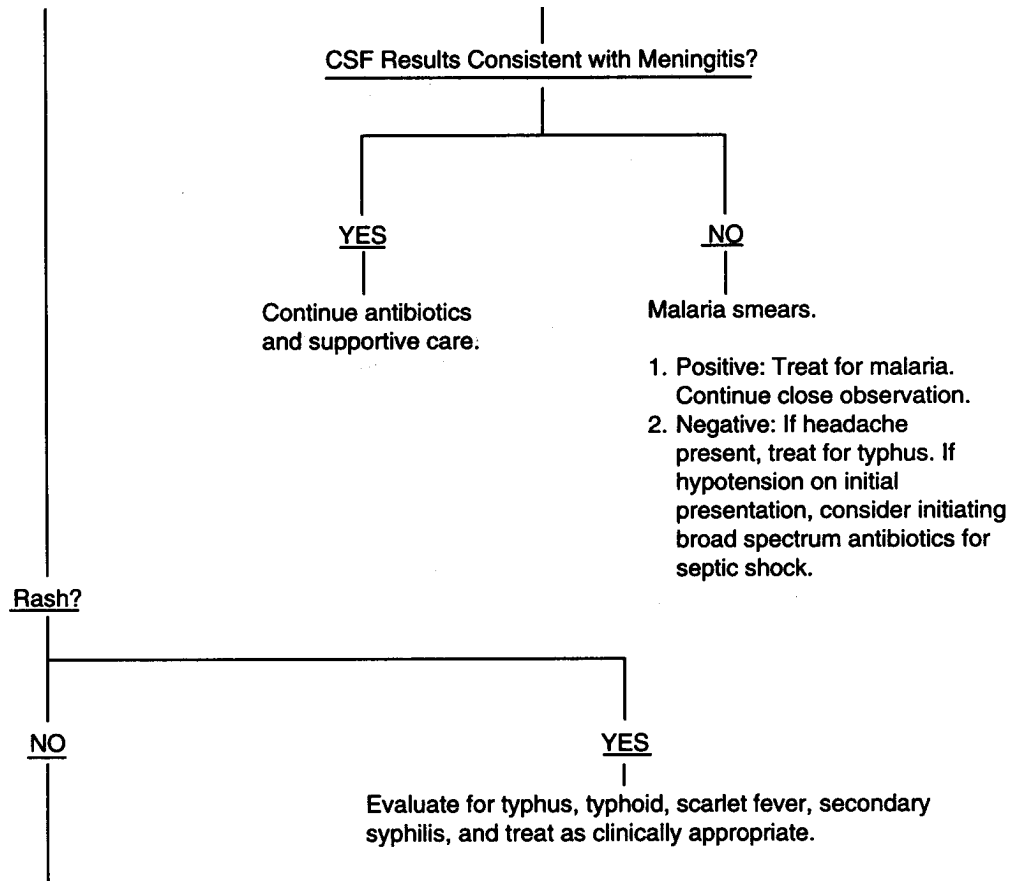


*Figure D-I. Model for an Approach to the Acutely Ill Febrile Patient (Example from the Middle East) (2 of 6)*

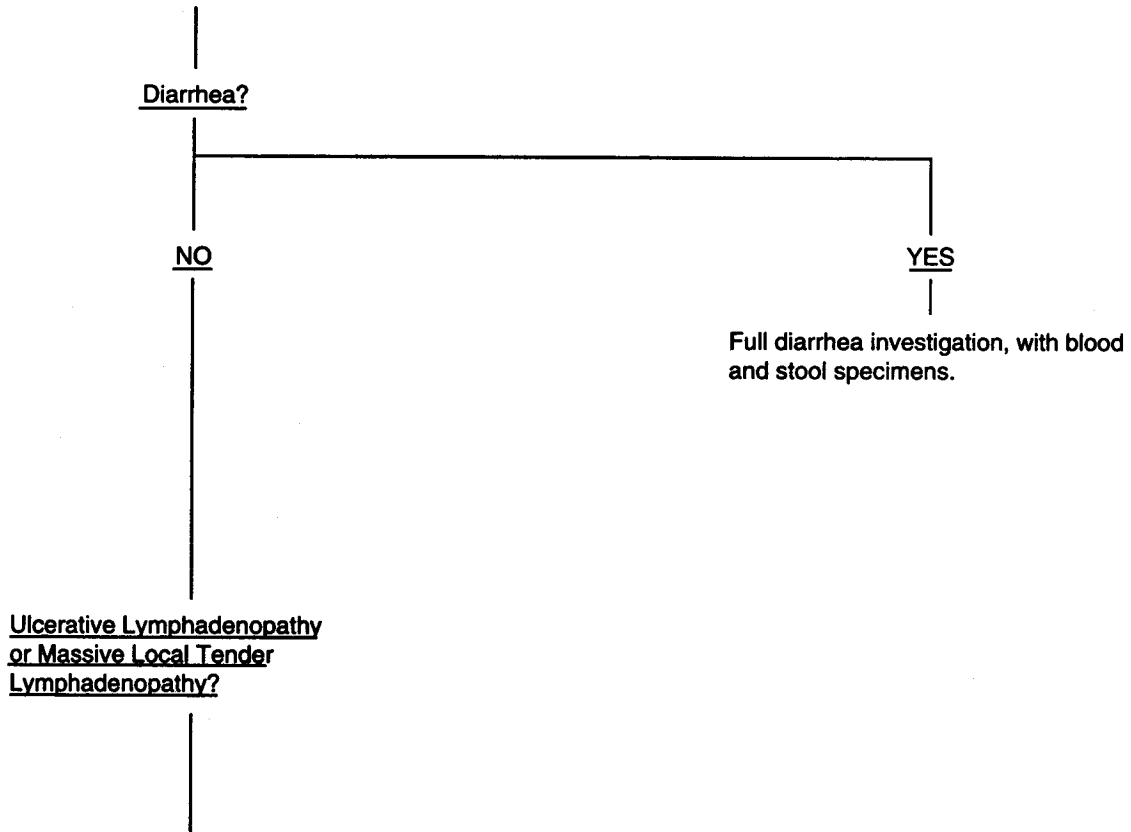


*Figure D-I. Model for an Approach to the Acutely Ill Febrile Patient  
(Example from the Middle East) (3 of 6)*

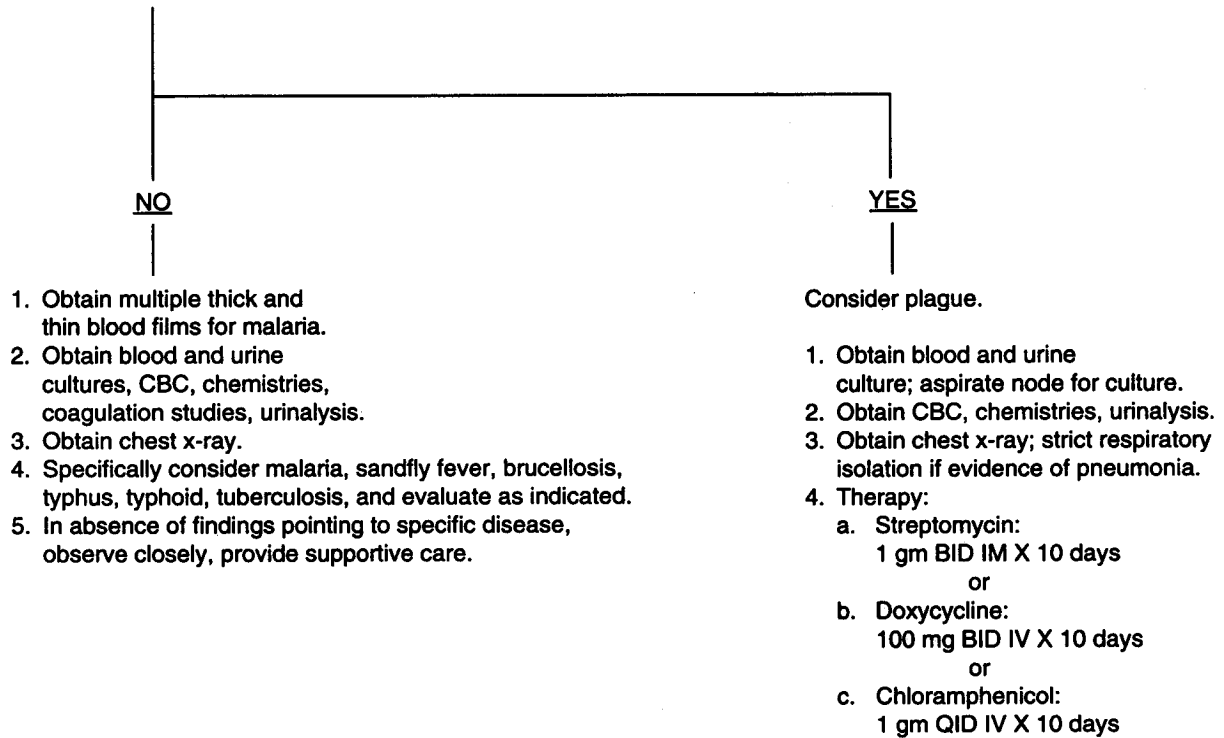




*Figure D-I. Model for an Approach to the Acutely Ill Febrile Patient (Example from the Middle East) (4 of 6)*



*Figure D-1. Model for an Approach to the Acutely Ill Febrile Patient  
(Example from the Middle East) (5 of 6)*



*Figure D-I. Model for an Approach to the Acutely Ill Febrile Patient  
(Example from the Middle East) (6 of 6)*

*Table D-II. An Approach to Potential BW Agents by Predominant Clinical Finding or Syndrome*

Syndrome	General characteristics	Potential causes*
Fever		Any (Toxins less likely)
Grippe-like	Fever, chills, malaise, headache, myalgia, eye pain, hyperaesthesias	Brucellosis Rift Valley fever Venezuelan equine encephalitis Q-fever Influenza Dengue fever Chikungunya fever Inhalation anthrax (early)
Pharyngitis	Sore throat, dysphagia, with or without fever	Lassa Botulinum toxins Ebola/Marburg Tularemia Trichothecene mycotoxins Ricin
Rash-maculopapular	All rash syndromes typically accompanied by fever	Rocky Mountain spotted fever Scrub typhus Epidemic typhus Ebola/Marburg Argentine hemorrhagic fever Bolivian hemorrhagic fever Dengue fever Chikungunya fever Tularemia (uncommon) Psittacosis (uncommon) Smallpox (early)
Rash-vesiculopustular		Smallpox Melioidosis Tularemia
Rash-granulomatous or ulcerative		Melioidosis Tularemia

*Table D-II. An Approach to Potential BW Agents by Predominant Clinical Finding or Syndrome (Continued)*

Syndrome	General characteristics	Potential causes*
Rash-petechial/ ecchymotic		Korean hemorrhagic fever Crimean-Congo hemorrhagic fever Rocky Mountain spotted fever Plague Smallpox (rare, fulminant) Argentine hemorrhagic fever Bolivian hemorrhagic fever Lassa Dengue fever Ebola/Marburg Rift Valley fever (infrequent) Omsk hemorrhagic fever Yellow fever Scrub typhus Epidemic typhus Trichothecene mycotoxins
Diarrhea-dysentery	Typically with fever	Shigella
Diarrhea-watery	With or without fever	Cholera Staphylococcus enterotoxin B Lassa Ebola/Marburg
Jaundice	With or without fever	Yellow fever Lassa Ebola/Marburg Toxins (especially aflatoxin)
Hemorrhagic fever	Fever; hypotension, with or without fever	Lassa Ebola/Marburg Crimean-Congo hemorrhagic fever Omsk hemorrhagic fever Argentine hemorrhagic fever Bolivian hemorrhagic fever Yellow fever Dengue fever Trichothecene mycotoxins Plague Korean hemorrhagic fever Rift Valley fever (infrequent)

*Table D-II. An Approach to Potential BW Agents by Predominant Clinical Finding or Syndrome (Continued)*

Syndrome	General characteristics	Potential causes*
Encephalitis/ encephalopathy	With or without fever	Eastern equine encephalitis Western equine encephalitis Venezuelan equine encephalitis Russian spring-summer encephalitis Argentine hemorrhagic fever Bolivian hemorrhagic fever Lassa Psittacosis Plague Rift Valley fever (infrequent)
Stiff neck syndrome	Typically with fever	Eastern equine encephalitis Western equine encephalitis Venezuelan equine encephalitis Psittacosis Histoplasmosis
Flaccid paralysis	Sensory paresthesias, flaccid weakness, cranial nerve abnormalities	Botulinum toxins Saxitoxin Tetrodotoxin
Oliguric renal failure	Typically with fever	Korean hemorrhagic fever Yellow fever Psittacosis (rarely)
Pulmonary syndrome	Pneumonia, respiratory insufficiency, respiratory distress; usually with f	Anthrax Tularemia Plague Psittacosis Q fever Histoplasmosis Coccidioidomycosis Influenza Omsk hemorrhagic fever Crimean-Congo hemorrhagic fever Korean hemorrhagic fever Ricin Staphylococcus enterotoxin B Botulinum toxin

*Table D-II. An Approach to Potential BW Agents by Predominant Clinical Finding or Syndrome (Continued)*

Syndrome	General characteristics	Potential causes*
Polyarthritis/ polyarthralgia	Typically with fever	Chikungunya fever
Rapid death syndrome	Death within minutes; fever may be present	Saxitoxin Tetrodotoxin Botulinum toxins Trichothecene mycotoxins Other toxins Chemical agents

\* This list is cross-referenced to Annex A, and is not intended to be comprehensive. It does not suggest that clinical presentation of a given agent will necessarily be that of a syndrome listed. This table should serve only as a guide; additional clinical findings must be considered in each case in an attempt to obtain a definitive diagnosis.

## REFERENCES

## Sources of Additional Information

*Control of Communicable Diseases in Man.* American Public Health Association, 15th Edition, New York, 1990.

*Diagnosis and Treatment of Diseases of Tactical Importance to US CENTCOM Forces, 1991.* Office of the US Army Surgeon General, Falls Church, VA 22041 (2nd Edition - January 1991).

Geissler, E. *Biological and Toxin Weapons Today.* Stockholm International Peace Research Institute, Oxford University Press, New York, 1986.

*Health Aspects of Chemical and Biological Weapons.* Report of WHO Group Consultants, WHO, Geneva, 1970.

Mandell, G., Douglas, R., Bennett, J. *Principles and Practice of Infectious Diseases, 3rd Edition.* Churchill Livingstone, New York, 1990.

*Manual of NBC Defence Training on Land.* (AC No 71328/AP 3395, 2nd Edition/BR 8456.) Pamphlet No 6. A NBC Guide for Medical Personnel.

*NATO Handbook on Medical Aspects of NBC Defensive Operations.* Part 3 (Chemical) (AMedP-6(B)).

*NATO Handbook on the Concept of Medical Support in NBC Environments.* (AMedP-7(a).)

Wiener, S. and Barret, J. *Trauma Management for Civilian and Military Physicians.* W. B. Saunders and Co., Philadelphia, PA, 1986.



## GLOSSARY

AFU	air filtration unit
AST	aspartate aminotransferase
ATA	alimentary toxic aleukia
BA	biological agent
BD	biological defense
bid	<i>bis in die</i> (twice daily)
BW	biological warfare
cc	cubic centimeter(s)
CCHF	crimean-xongo hemorrhagic fever
CNS	central nervous system
Colpro	collective protection
CO <sub>2</sub>	carbon dioxide
CSF	cerebrospinal fluid
daltons	unit of mass -1.657 x 10 <sup>-24</sup>
DIC	disseminated intravascular coagulation
DNA	deoxyribonucleic acid
ELISA	enzyme-linked immunosorbant assay
FA	fluorescent assay
g	gram(s)
GC	gas-liquid chromatography
GI	gastrointestinal
HCl	hydrochloric acid
HPLC	high pressure liquid chromatography
ICLC	lysine-polyadenosine
IgG	immunoglobulin G
IgM	immunoglobulin M
IM	intramuscular
IND	investigational new drug
ip	inter peritoneal
IPE	individual protective equipment
IV	intravenous
kg	kilogram(s)
mg	milligram(s)
ml	milliliter(s)
mm	millimeter(s)
NBC	nuclear, biological, and chemical
PA	protective antigen
po	<i>per os</i> (orally)
PSP	paralytic shellfish poisoning
q	quaque (every)
qid	<i>quater in die</i> (four times a day)
RNA	ribonucleic acid

RVF	Rift Valley fever
SEB	staphylococcal enterotoxin B
tid	<i>ter in die (three times daily)</i>
VEE	Venezuelan equine encephalitis

INDEX

	Paragraph
aerosol	104, 106, 201, 204, 304-305, 307, 405
alimentary exposure	106
anthrax	201, 204, 308, 405
antigen	208
bacteria	105, 207, 403, 407
biodetector	202
biological agent	101-106, 201, 206, 303-308, 401, 403, 405, 411-413
Biological Defense	101
Biological Warfare	101, 209, 211, 212, 301, 303-304, 308, 401
casualty management	104, 408
chemoprophylaxis	307-308
Chlamydia	105, 403
cohorting	403
collection	205-207
contamination	106, 212, 303, 306, 402, 404
dermal exposure	106, 305, 402
etiologic	106, 208, 413, 415
formalin	207
fungi	105
genome	208
immunoassay	208
immunofluorescence	207
incubation period	104, 106, 308, 413
infectivity	104
isolation procedures	403
labelling	207
lethality	104,
mass casualty	408-409
microorganism	101, 104-106, 204
pathogenicity	104
polymerase chain reaction	207
primary contamination	402
quarantine	403
respiratory	106, 204, 305, 405, 410
Rickettsiae	105
sampling	206-207
sanitation	212, 302-303
secondary contamination	402
serum	207, 307
stability	104

	Paragraph
supportive measures	403
therapy	105, 301, 403, 410-411
toxicity	104
toxin	101-106, 201, 204, 208, 405, 407, 410, 412
transmissibility	104-105
virulence	104
virus	105, 403, 407
yellow rain	102

**NATO HANDBOOK ON THE MEDICAL ASPECTS  
OF NBC DEFENSIVE OPERATIONS  
AMedP-6(B)**

**PART III - CHEMICAL**

**1 FEBRUARY 1996**

## TABLE OF CONTENTS

	Page
<b>CHAPTER 1 INTRODUCTION</b>	
Paragraph 101. Definition	1-1
102. Historical	1-1
103. General Factors Influencing the Employment and Choice of Chemical Agents	1-2
104. Characteristics	1-3
105. Terminology	1-3
106. Routes of Absorption	1-4
 <b>CHAPTER 2 NERVE AGENTS</b>	
<b>SECTION I - GENERAL</b>	
Paragraph 201. Introduction	2-1
202. Physical and Chemical Properties	2-1
203. Detection	2-2
204. Protection	2-2
205. Decontamination	2-2
206. Mechanism of Action	2-2
207. Pathology	2-3
<b>SECTION II - EFFECTS OF NERVE AGENTS</b>	
Paragraph 208. Signs and Symptoms	2-4
209. Effects of Nerve Agent Vapour	2-4
210. Effects of Liquid Nerve Agent	2-6
211. Systemic Effects of Nerve Agent Poisoning	2-7
212. Muscarinic Effects of Nerve Agent Poisoning	2-7
213. Nicotinic Effects	2-9
214. Central Nervous System Effects	2-9
215. Cumulative Effects of Repeated Exposure	2-10
216. Cause of Death	2-10
<b>SECTION III - TREATMENT OF NERVE AGENT POISONING</b>	
Paragraph 217. Diagnosis and Therapy of Nerve Agent Poisoning	2-10
218. Treatment	2-11
219. Pretreatment	2-12
220. Post-Exposure Therapy	2-13
221. Emergency Field Therapy	2-13
222. Pharmacological Treatment of Nerve Agent Poisoning	2-14
223. Atrophine	2-14
224. Oximes	2-15
225. Anticonvulsants	2-18
226. Supportive Care	2-18
 <b>CHAPTER 3 VESICANTS (BLISTER AGENTS)</b>	
<b>SECTION I - MUSTARD AND NITROGEN MUSTARDS</b>	
Paragraph 301. Introduction	3-1
302. Mustard Agents	3-1
303. Physical and Chemical Properties	3-2
304. Detection	3-2
305. Protection	3-2

	Page
Paragraph 306. Decontamination	3-3
307. Mechanism of Action	3-4
308. Toxicity	3-4
<b>SECTION II - CLINICAL-PATHOLOGICAL EFFECTS</b>	
Paragraph 309. Eyes	3-5
310. Skin	3-6
311. Respiratory Tract	3-7
312. Bone Marrow	3-8
313. Gastrointestinal Tract	3-8
314. Systemic Action	3-8
<b>SECTION III - TREATMENT OF MUSTARD LESIONS</b>	
Paragraph 315. Prophylaxis	3-8
316. Therapy	3-8
317. Eye Lesions	3-8
318. Skin Lesions	3-9
319. Respiratory Tract Lesions	3-9
320. Systemic Effects	3-10
321. Burns Caused by High Doses of Vapour	3-10
322. Burns Caused by Low Doses of Vapour	3-10
323. Sensitisation Due to Multiple Exposures to Mustard	3-10
324. Disposition of Casualties	3-11
325. Trunk and Neck	3-11
326. Arms	3-12
327. Hands	3-12
328. Lower Extremities	3-13
329. Genitalia	3-14
330. Systemic Effects of Cutaneous Burns	3-15
331. Secondary Bacterial Infection in Blister Agent Burns	3-15
332. Course and Prognosis	3-16
333. Long Term Effects of Mustard Gas Poisoning	3-16
<b>SECTION IV - ARSENICAL VESICANTS - LEWISITE</b>	
Paragraph 334. Introduction	3-17
335. Physical and Chemical Properties	3-17
336. Detection	3-17
337. Protection	3-17
338. Decontamination	3-17
339. Mechanism of Action	3-19
<b>SECTION V - CLINICAL-PATHOLOGICAL EFFECTS</b>	
Paragraph 340. Eyes	3-19
341. Skin	3-20
342. Respiratory Tract	3-20
343. Systemic Effects	3-20
<b>SECTION VI - TREATMENT OF LEWISITE LESIONS</b>	
Paragraph 344. General	3-21
345. Eyes	3-21
346. Skin	3-21
347. Systemic	3-22

	Page
Paragraph 348. Indication for Systemic Treatment	3-22
349. Types of Treatment	3-22
350. Therapy	3-23
351. Course and Prognosis	3-24
<b>SECTION VII- HALOGENATED OXIMES</b>	
Paragraph 352. Introduction	3-24
353. Physical and Chemical Properties of Phosgene Oxime	3-24
354. Detection	3-24
355. Protection	3-25
356. Decontamination	3-25
357. Mechanism of Action	3-25
358. Clinical-Pathological Effects	3-25
359. Treatment	3-25
360. Course and Prognosis	3-25
<b>CHAPTER 4 LUNG DAMAGING AGENTS (CHOKING AGENTS)</b>	
<b>SECTION I - GENERAL</b>	
Paragraph 401. Introduction	4-1
<b>SECTION II - PHOSGENE</b>	
Paragraph 402. Physical and Chemical Properties	4-1
403. Detection	4-1
404. Protection	4-1
405. Decontamination	4-2
406. Mechanism of Action	4-2
407. Clinical-Pathological Effects	4-3
408. Signs and Symptoms	4-3
409. Treatment	4-3
410. Course and Prognosis	4-4
<b>CHAPTER 5 CYANOGEN AGENTS (BLOOD AGENTS)</b>	
<b>SECTION I - GENERAL</b>	
Paragraph 501. Introduction	5-1
<b>SECTION II - HYDROGEN CYANIDE</b>	
Paragraph 502. Properties	5-1
503. Detection	5-2
504. Protection	5-2
505. Decontamination	5-2
506. Mechanism of Action	5-2
507. Signs and Symptoms	5-2
508. Treatment	5-3
509. Case Management	5-3
510. Treatment Approaches	5-3
511. Drugs That Bind Cyanide Ions	5-3
512. Provision of Sulphur Groups	5-4
513. Additional Therapy	5-5
514. Course and Prognosis	5-5



	Page
<b>SECTION III - CYANOGEN HALIDES</b>	
Paragraph 515. Introduction	5-5
516. Physical and Chemical Properties	5-5
517. Detection	5-5
518. Decontamination	5-5
519. Mechanism of Action	5-6
520. Pathology	5-6
521. Signs and Symptoms	5-6
522. Treatment	5-7
523. Course and Prognosis	5-7
<b>CHAPTER 6 INCAPACITANTS</b>	
<b>SECTION I - GENERAL</b>	
Paragraph 601. Introduction	6-1
602. CNS Depressants	6-1
603. CNS Stimulants	6-2
604. Detection	6-2
605. Protection	6-2
606. Decontamination	6-3
<b>SECTION II - CNS DEPRESSANTS - BZ (3-QUINOCLINIDINYL BENZOATE) AND SIMILAR COMPOUNDS</b>	
Paragraph 607. Detection	6-3
608. Protection	6-4
609. Properties	6-4
610. Mechanism of Action	6-4
611. Signs and Symptoms	6-4
612. Treatment	6-5
<b>SECTION III - CNS STIMULANTS - LSD (D-LYSERGIC ACID DIETHYLAMIDE)</b>	
Paragraph 613. Properties	6-5
614. Detection	6-5
615. Protection	6-5
616. Mechanism of Action	6-6
617. Pathophysiology	6-6
618. Signs and Symptoms	6-6
619. Treatment	6-7
620. Course and Prognosis	6-7
621. Other Agents	6-7
<b>CHAPTER 7 RIOT CONTROL AGENTS</b>	
<b>SECTION I - GENERAL</b>	
Paragraph 701. Introduction	7-1
<b>SECTION II - LACHRYMATORS</b>	
Paragraph 702. CS (Orthochlorobenzlidene Malononitrile)	7-1
703. Properties	7-1
704. Detection	7-1
705. Protection	7-2
706. Decontamination	7-2


	Page
Paragraph 707. Mechanism of Action	7-2
708. Pathology	7-2
709. Signs and Symptoms	7-2
710. CS Exposure Symptoms	7-2
711. First Aid	7-3
712. Therapy	7-3
713. Course and Prognosis	7-4
714. CR (Dibenzoxazepine)	7-4
715. CN (Chloracetophenone)	7-4
716. Properties	7-4
717. Mode of Action and Toxic Effects	7-4
718. Signs and Symptoms	7-5
719. First Aid	7-5
720. CA (Bromobenzl Cyanide) and BA (Bromoacetone)	7-5
<b>SECTION III - VOMITING AGENTS</b>	
Paragraph 721. Introduction	7-6
722. Properties	7-6
723. Detection	7-7
724. Protection	7-7
725. Mechanism of Action	7-7
726. Pathology	7-7
727. Signs and Symptoms	7-7
728. Treatment	7-8
729. Course and Prognosis	7-8
<b>CHAPTER 8 SMOKES, FUELS, AND INCENDIARY MATERIALS</b>	
<b>SECTION I - SMOKES</b>	
Paragraph 801. Introduction	8-1
802. Zinc Chloride Smokes	8-1
803. Protection	8-1
804. Clinical-Pathological Effects	8-1
805. Treatment	8-2
806. Prognosis	8-2
807. Chlorosulphonic Acid (CSA)	8-2
808. Symptoms	8-3
809. Treatment	8-3
810. Prognosis	8-3
811. Titanium Tetrachloride (FM)	8-3
812. Mode of Action	8-3
<b>SECTION II - FLAME MATERIALS</b>	
Paragraph 813. General	8-4
814. Red and White Phosphorus	8-4
815. Self Aid	8-4
816. Medical Aid	8-5
817. Thermite	8-5
818. Treatment	8-5
819. Magnesium	8-5

	Page
SECTION III - HYDROCARBON FUMES	
Paragraph 820. General	8-6
821. Physical and Chemical Properties	8-6
822. Protection	8-6
823. Mechanism of Action	8-6
824. Signs and Symptoms	8-6
825. Treatment	8-7
SECTION IV - INCENDIARY DEVICES - COMBUSTIBLE HYDROCARBON INCENDIARIES	
Paragraph 826. Introduction	8-7
827. Flame-Thrower Attack	8-7
828. Casualties	8-7
829. Protection	8-7
830. Treatment	8-7
831. Fire-Bomb Attack	8-8
832. Casualties	8-8
833. Treatment	8-8
CHAPTER 9      HERBICIDES	
SECTION I    - GENERAL	
Paragraph 901. Introduction	9-1
SECTION II   - 2,4,-D AND 2,4,5-T	
Paragraph 902. Toxicity	9-2
903. Biochemistry	9-2
904. Mechanism of Action	9-2
905. Signs and Symptoms	9-2
906. Treatment	9-2
SECTION III - CACODYLIC ACID	
Paragraph 907. Toxicity	9-3
908. Biochemistry	9-3
909. Mechanism of Action	9-3
910. Signs and Symptoms	9-3
911. Treatment	9-3
SECTION IV - PICLORAM	
Paragraph 912. Toxicity	9-3
913. Mechanism of Action	9-4
914. Signs and Symptoms	9-4
915. Treatment	9-4
CHAPTER 10    RECOGNITION OF A CHEMICAL CASUALTY	
Paragraph 1001. Introduction	10-1
1002. General	10-1
1003. Recognition of a Casualty of Chemical Operations	10-1
1004. Questioning Casualties	10-2
1005. Types of Casualties	10-3

	Page
CHAPTER 11	MEDICAL SUPPORT IN CHEMICAL OPERATIONS
SECTION I	- INTRODUCTION
Paragraph	1101. General 11-1
	1102. Objectives of Medical Support in Chemical Operations 11-1
	1103. Characteristics of Chemical Agents 11-1
	1104. Contamination Control 11-2
	1105. Mass Casualties 11-3
	1106. Medical Decision Making 11-3
	1107. Triage 11-4
SECTION II	- CASUALTY MANAGEMENT PHASES
Paragraph	1108. General 11-5
	1109. Phase I - Pre-Attack 11-6
	1110. Phase II - Immediate Post-Attack/Self Aid 11-6
	1111. Phase III - Buddy Aid 11-7
	1112. Phase IV - Initial Medical Care 11-7
	1113. Phase V - Life Support/Stabilisation 11-8
	1114. Phase VI - Evacuation 11-8
	1115. Phase VII - Casualty Decontamination 11-8
	1116. Phase VIII - Definitive Care 11-9
	1117. Phase IX - Disposition 11-9
SECTION III	- COMBINED INJURIES
Paragraph	1118. Introduction 11-9
SECTION IV	- NON PERSISTENT AGENTS
Paragraph	1119. Injury Complicated by Exposure to a Non Persistent Nerve Agent 11-10
	1120. Injury Complicated by Exposure to Lung Damaging Agents 11-11
	1121. Injury Complicated by Exposure to Cyanogen Agents 11-11
SECTION V	- PERSISTENT AGENTS
Paragraph	1122. Injury Complicated by Persistent Nerve Agents 11-11
	1123. Injury Complicated by Contamination with Vesicant Agent 11-12
SECTION VI	- OTHER CONSIDERATIONS
Paragraph	1124. Collective Protection 11-13
	1125. Head Wounds 11-13
	1126. Heat Stress 11-13
CHAPTER 12	DISPOSITION OF CONTAMINATED FOOD AND WATER
SECTION I	- GENERAL
Paragraph	1201. Introduction 12-1
SECTION II	- EFFECTS OF CHEMICAL AGENTS ON FOOD AND WATER
Paragraph	1202. General 12-1
	1203. Penetration 12-1
	1204. Effect on Food 12-2
	1205. Effect on Crops 12-2
	1206. Effect on Livestock 12-3

	Page
SECTION III - PROTECTION OF FOOD AND WATER AGAINST CONTAMINATION WITH CHEMICAL AGENTS	
Paragraph 1207. Packaging Materials	12-3
1208. Disposition of Packaged and Stored Supplies	12-4
SECTION IV - MONITORING FOR CONTAMINATION	
Paragraph 1209. Monitoring Food	12-4
SECTION V - DECONTAMINATION OF FOOD AND WATER	
Paragraph 1210. Classification of Supplies	12-5
1211. Water	12-5
1212. Monitoring Water	12-6
1213. Decontamination of Water	12-6
ANNEX	
A    BIOCHEMICAL ACTION OF NERVE AGENTS	A-1
B    PHARMACOLOGY OF OXIMES	B-1
C    SUMMARY OF THE EFFECTS OF CHEMICAL AGENTS	C-1
REFERENCES	References-1
GLOSSARY	Glossary-1
INDEX	Index-1
LIST OF EFFECTIVE PAGES	LEP-1

## List of Tables

		Page	
Table	2-I.	Physical Properties of Nerve Agents	2-1
	2-II.	Likely Signs and Symptoms of GB Poisoning Shown in Terms of Vapour Exposure and Approximate Blood Acetylcholinesterase Depression	2-4
	2-III.	Signs and Symptoms of Nerve Agent Poisoning	2-5
	2-IV.	Time Course of Effects of Nerve Agents	2-8
	2-V.	Effectiveness of Various Oximes in the Treatment of Nerve Agent Poisoning	2-16
	2-VI.	Examples of Current Dosing Scheme for the Intravenous Administration of Oximes	2-16
	2-II.	Loading Doses and Infusion Rates for Oxime Administration to Obtain a Plasma Concentration of 4 mg.l <sup>-1</sup>	2-17
	3-I.	Physical Properties of Vesicants	3-18
	4-I.	Physical Properties of Lung Damaging Agents	4-2
	5-I.	Physical Properties of Cyanogen Agents	5-6
	6-I.	Signs and Symptoms Produced by Incapacitating Agents	6-3
	7-I.	Properties of CA and BA	7-5
	7-II.	Properties of Vomiting Agents	7-6
	9-I.	Composition of Herbicides	9-1
	11-I.	Potential Interactions of Chemical/Conventional Injuries	11-10
	11-II.	Heat Casualty Prevention Guide	11-14
	12-I.	Effect of Certain Agents on the Appearance of Food	12-2
	12-II.	Effect of Chemical Agents on Food	12-3
	12-III.	Maximum Allowable Concentrations of Agents in Drinking Water	12-6
	C-I.	Effects of Chemical Agents	C-3

## CHAPTER 1

## INTRODUCTION

**101. Definition.**

The NATO definition of a chemical agent is: A chemical substance which is intended for use in military operations to kill, seriously injure or incapacitate people because of its physiological effects. Excluded from this definition are riot control agents, herbicides, smoke and flame. Structural formulae and physical properties of some of the more important compounds are shown in figures and tables in the appropriate chapters. Brief consideration of riot control agents, herbicides and smoke and flame materials are also included in this text. It must be remembered that possible new agents are constantly being discovered, and also, that some chemical agents may be used together as a mixture. Toxins are discussed in AMedP-6(B), Part II. From the medical standpoint, toxins could pose similar problems to those produced by chemical agents. By constant vigilance on the part of all medical personnel in looking for new or unexpected syndromes, and by prompt reporting of any suspicious event, the use of new or mixed agents can be discovered.

**102. Historical.**

- a. Chemical agents in the modern sense were first used in World War I, when chlorine gas was released, from large cylinders, in a favorable wind. This surprise operation caused massive casualties, demoralisation of the forces attacked and demonstrated the need for protection from this kind of warfare. The first improvised mask was a cotton pad soaked in sodium thiosulphate, glycerine and sodium carbonate. Subsequently in World War I, a great variety of chemical agents were used by both sides, the most damaging being the blister producing mustard gas. Military clothing, even with a respirator, gave little protection against this agent. Chemical agents were not used in World War II, but at the end of the war stockpiles of newer agents, called "nerve gases," were discovered. These were found to be effective in much lower concentrations than those agents known up to that time. The standard of training and preparedness of the Services and the fear of retaliation were possible reasons why chemical agents were not used.
- b. Between World Wars I and II, mustard gas was used with considerable effect against unprotected troops. Since World War II, there have been several confirmed reports that chemical agents have been used in armed conflicts including the Iran-Iraq conflict.
- c. Riot control agents such as CS (tear agent) have been used repeatedly, for example, in South-East Asia to support tactical operations: in particular to flush out guerrillas from hiding and to render places of concealment untenable. These compounds and other tear agents are frequently used as riot control agents by police forces.
- d. The advent of nuclear weapons and the fact that chemical agents were not used in World War II did not prevent their use in recent conflicts and do not exclude the possibility of their use in a future war. The effectiveness of chemical agents as tactical weapons was clearly demonstrated in World War I and in the Iran-Iraq conflict. They can equally affect both forward and rear areas. It seems probable that

the nature and severity of casualties may differ in future from those recorded in World War I.

### 103. General Factors Influencing the Employment and Choice of Chemical Agents.

- a. The effective use of any chemical agent is dependent on its physical and chemical properties and on meteorological conditions.
  - (1) *Persistency*. Chemical agents may be divided into two main categories as follows: Non-persistent and persistent agents.
    - (a) Non-persistent agents disperse rapidly after release and present an immediate, short duration hazard. They are released as airborne particles, liquids and gases, and intoxication usually results from inhalation.
    - (b) Persistent agents continue to present a hazard for considerable periods after delivery by remaining as contact hazard or by vaporizing over a period to produce a hazard by inhalation. Non-persistent agents may be made persistent by thickening.
  - (2) *Effectiveness*. Effectiveness is the capacity of an agent to produce the maximum number of casualties or amount of disruption of operations with the least amount of agent, although other tactical criteria may be used to gauge this effectiveness. "Effectiveness" is a general term which takes in such criteria as suitability, toxicity, irritancy, etc. For instance, of two similar volatile toxic agents, the one which is toxic at a lower dose can be said to be more effective. Similarly, of two irritant compounds, the one which is irritant at a lower dose can be said to be the more effective. Effectiveness is also dependent on the ability of the population attacked to neutralise or counter the effects of agents once they have been delivered. The duration of effectiveness depends on the physical characteristics of the agent, the amount of agent delivered, the weapon system used and the terrain and weather in the target area at the time the agent is delivered and later.
- b. The following meteorological factors will influence the duration of effectiveness of chemical agents:
  - (1) *Winds*. The effect of wind is to disperse agents rapidly in open country. However, dangerous concentrations may remain longer in woods, trenches, dug-outs and built-up areas.
  - (2) *Temperature*. High temperatures decrease the persistency of agents and cause higher vapour concentrations. Low temperatures increase the persistency of agents. Some agents may freeze thus reducing the immediate contact hazard. There is a danger of carrying such frozen agents on clothing and equipment into a warm building with the subsequent risk of toxic vapour being given off.
  - (3) *Rain*. Rain disposes, dilutes and promotes hydrolysis of agents. This reduces their effectiveness but does not make them impossible to use.
  - (4) *Atmospheric Stability*. When the air temperature is higher than that at ground level (a state of inversion), agents in the vapour state will persist for longer periods than when the air temperature is lower than that at ground level (a state of lapse).



## 104. Characteristics.

- a. *Physical.* Known agents cover the whole range of physical properties. Under ambient conditions their physical state may be gaseous, liquid or solid. Their vapour pressures vary from high to negligible. Their vapour densities vary from slightly lighter to considerably heavier than air. The range of odours varies from none to highly pungent or characteristic. They may be soluble or insoluble in water. In the following chapters the physical properties of various agents are given in tables in the appropriate chapter. These may give an indication of the behaviour of the agents in the field with regard to vapour hazard, persistency and possible means of decontamination, etc. Agents with a low boiling point and high vapour pressure tend to be non-persistent. Agents with a high boiling point and low volatility tend to be more persistent.
- b. *Chemical.* The only general characteristic of the known agents is that they are sufficiently stable to survive dissemination and transport to the site of their biological action. Their inherent reactivity and stability can vary widely. Some chemically reactive agents denature rapidly, whereas other less reactive agents require, for example, bleach solutions to inactivate them. Solid absorbents (e.g., fullers' earth) are very effective decontaminants but do not denature agents and the potential for off-gassing should be recognised.
- c. *Toxicological.*
  - (1) It should be realised that not all individuals of a species react in the same way to a given amount of agent, some being more or less sensitive as a result of many factors, of which genetic background, race and age are examples. Also, toxicological studies estimate the biological effects of potential agents by different routes of exposure. The physical properties of such materials may affect the toxicological studies since the response of the biological system concerned may vary depending on the physical state of the material.
  - (2) Studies of the mode of action are related to the development of medical countermeasures and physical protection devices.

## 105. Terminology.

The terminology used in this manual is as follows:

- a. *Dose.* The dose is the quantity of the compound received by the subject.
- b. *LD<sub>50</sub>.* The LD (lethal dose)<sub>50</sub> is the dose which kills 50% of the exposed population.
- c. *ID<sub>50</sub>.* The ID (incapacitating dose)<sub>50</sub> is the dose which incapacitates 50% of the exposed population.
- d. *Ct (Concentration time).* The Ct is a measure of exposure to a vapour or aerosol. The concentration in the air and the time of exposure govern the dose received, as does rate of respiration. It is assumed that, when the product of concentration and time is constant, so is the biological effect over a limited range of concentration and time. For very short or long exposures the biological effect may vary. Concentration is expressed as mg.m<sup>-3</sup> and time as minutes, so that the concentration time (Ct) is expressed as mg.min.m<sup>-3</sup>.

- e.  $LCt_{50}$  The  $LCt$  (lethal concentration time)<sub>50</sub> is the  $Ct$  which will kill 50% of the exposed population.
- f.  $ICt_{50}$  The  $ICt$  (incapacitating concentration time)<sub>50</sub> is the  $Ct$  which will incapacitate 50% of the exposed population.

### **106. Routes of Absorption.**

Chemical agents may enter the body by several routes and the nature and onset of signs and symptoms may vary accordingly. Gases, vapours and aerosols, when inhaled, may be absorbed through any part of the respiratory tract, from the mucosa of the nose and mouth to the alveoli of the lungs. They may also be directly absorbed by the eye. Aerosol particles larger than 5  $\mu\text{m}$  tend to be retained in the upper respiratory tract, while those smaller than 1  $\mu\text{m}$  tend to be breathed in and out again, although some of these smaller particles may be retained. Droplets of liquid and, less commonly, solid particles may be absorbed through the surface of the skin and mucous membranes. Toxic compounds with a characteristic action on the skin can produce their effects when deposited on the skin as solid or liquid particles. Agents which penetrate the skin may form temporary reservoirs so that delayed absorption may occur. Even the vapour of some volatile agents can penetrate the intact skin and intoxication may follow. Wounds or abrasions (even minor injuries caused by shaving or by chemical depilation) present areas which are more permeable than intact skin. Chemical agents may contaminate food and drink and so be absorbed by the gastrointestinal tract. The penetration of agents by these various routes may not be accompanied by irritation or damage to the surfaces concerned.

## CHAPTER 2

## NERVE AGENTS

## SECTION I - GENERAL

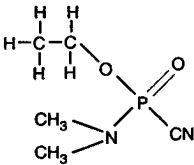
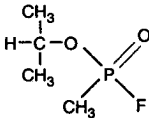
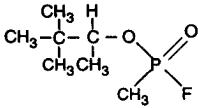
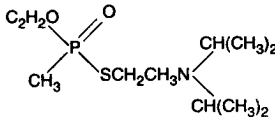
## 201. Introduction.

The nerve agents (NA) are a group of particularly toxic chemical warfare agents. They were developed just before and during World War II and are related chemically to the organophosphorus insecticides. The principle agents in this group are: GA (Tabun), GB (Sarin), GD (Soman), GF and VX (methylphosphonothioic acid). (In some countries the "V" agents are known as "A" agents.)

## 202. Physical and Chemical Properties.

- a. Nerve agents are organophosphorus esters. The "G" agents tend to be non-persistent whereas the "V" agents are persistent. Some "G" agents may be thickened with various substances in order to increase their persistence, and therefore the total amount penetrating intact skin. The physical properties are given in Table 2-I.

Table 2-I. Physical Properties of Nerve Agents

Property	Tabun (GA)	Sarin (GB)	Soman (GD)	VX
Appearance	Colourless to brown liquid giving off colourless vapour	Colourless liquid giving off a colorless vapour	Colourless liquid giving off a colourless vapour	Amber coloured liquid
Chemical formula				
Molecular weight	162.12	140.10	182.2	267.4
Density (g.cm <sup>-3</sup> at 25°C)	1.07	1.09	1.02	1.01
Melting point	-50.0°C	-57.0°C	-42.0°C	-51.0°C
Boiling point	240.0°C	147.0°C	198.0°C	298.0°C
Vapour density	5.63	4.86	6.33	9.2
Vapour pressure (mmHg at 25°C)	0.07	2.9	0.4	0.007
Volatility (mg.m <sup>-3</sup> )	90 (0°C) 610 (25°C) 858 (30°C)	4,100 (0°C) 22,000 (25°C) 29,800 (30°C)	531 (0°C) 3,900 (25°C) 5,570 (30°C)	10.5 (25°C)

- b. It may be seen that at room temperature GB is a comparatively volatile liquid and therefore non-persistent. GD is also significantly volatile, as is GA though to a lesser extent. VX is a relatively non-volatile liquid and therefore persistent. It is regarded as presenting little vapour hazard to people exposed to it. In the pure state nerve agents are colorless and mobile liquids. In an impure state nerve agents may be encountered as yellowish to brown liquids. Some nerve agents have a faint fruity odour.
- c. In general, nerve agents are moderately soluble in water with slow hydrolysis, highly soluble in lipids, rapidly inactivated by strong alkalis and chlorinating compounds.

### 203. Detection.

Nerve agents may be detected by a variety of means. Single and three colour detector papers are available for individual issue to detect liquid nerve agent. Area detectors are also available as are monitoring devices for local contamination and water testing kits.

### 204. Protection.

- a. To prevent inhalation of an incapacitating or lethal dose it is essential that the breath is held and the respirator put on at the first warning of the presence, or suspected presence, of a nerve agent.
- b. Normal clothing is penetrated by these agents whether contact is with liquid or vapour and specialised clothing including a respirator, nuclear, biological, and chemical (NBC) suit, gloves and overboots are required for protection when liquid agent is present. The respirator protects the eyes, mouth and respiratory tract against nerve agent spray vapour and aerosol. Nerve agent vapour in field concentrations is absorbed through the skin very slowly, if at all, so that where a vapour hazard exists alone, the respirator may provide adequate protection without the use of an NBC suit.

### 205. Decontamination.

- a. The importance of early decontamination can not be over emphasised. Decontamination of the skin should be accomplished quickly if it is to be fully effective. Liquid agent may be removed by fullers' earth or chemically inactivated by the use of reactive decontaminants. Decontamination personnel should use a respirator and full protective equipment whilst decontamination is performed.
- b. Once a casualty has been decontaminated, or the agent fully absorbed, no further risk of contamination exists. The casualty's body fluids, urine or faeces do not present a chemical warfare (CW) hazard.

### 206. Mechanism of Action.

- a. *Absorption.* Nerve agents may be absorbed through any body surface. When dispersed as a spray or an aerosol, droplets can be absorbed through the skin, eyes and respiratory tract. When dispersed as a vapour at expected field concentrations, the vapour is primarily absorbed through the respiratory tract. If enough agent is absorbed, local effects are followed by generalised systemic effects. The rapidity

with which effects occur is directly related to the amount of agent absorbed in a given period of time.

**b. *Inhibition by Agents.***

- (1) The effects of the nerve agents are mainly due to their ability to inhibit acetylcholinesterase throughout the body. Since the normal function of this enzyme is to hydrolyse acetylcholine wherever it is released, such inhibition results in the accumulation of excessive concentrations of acetylcholine at its various sites of action. These sites include the endings of the parasympathetic nerves to the smooth muscle of the iris, ciliary body, bronchial tree, gastrointestinal tract, bladder and blood vessels; to the salivary glands and secretory glands of the gastrointestinal tract and respiratory tract; and to the cardiac muscle and endings of sympathetic nerves to the sweat glands. The accumulation of acetylcholine at these sites results in characteristic muscarinic signs and symptoms.
- (2) The accumulation of acetylcholine at the endings of motor nerves to voluntary muscles and in some autonomic ganglia results in nicotinic signs and symptoms.
- (3) The accumulation of excessive acetylcholine in the brain and spinal cord results in characteristic central nervous system symptoms. (See Table 2-II.)
- (4) The inhibition of cholinesterase enzymes throughout the body by nerve agents may be irreversible and its effects prolonged.
- (5) Treatment with oximes should begin promptly.
- (6) Until the tissue cholinesterase enzymes are restored to normal activity, there is a period of increased susceptibility to the effects of another exposure to any nerve agent. The period of increased susceptibility occurs during the enzyme regeneration phase which could last from weeks to months, depending on the severity of the initial exposure. During this period the effects of repeated exposures are cumulative.

**c. *Location of Acetylcholinesterase.*** Acetylcholinesterase is found associated with the post-junctional membrane at the neuromuscular junction and in the cell bodies and processes of cholinergic neurons. The concentration is particularly high in some central nervous system neurons. The location of acetylcholinesterase in autonomic ganglia is less well understood than that at the neuromuscular junction. Acetylcholinesterase is also found at sites where, as yet, no functional role has been identified: the musculotendinous junction, red blood cells, platelets and the placenta.

**d. *Further Information.*** Further information on the action of nerve agents on acetylcholinesterase is given in Annex A.

## **207. Pathology.**

Aside from the decrease in the activity of cholinesterase enzymes throughout the body (which may be detected by chemical methods or by special staining), no specific lesions are detectable by ordinary gross examination. At post-mortem examination there is usually capillary dilation, hyperaemia and oedema of the lungs; there may be similar changes in the brain and the remaining organs. Neuropathological changes have been reported in animals following severe intoxication. During the acute phase these include damage within the central nervous system and

at the neuromuscular endplate. Later on, following severe exposure to some nerve agent, lesions to the peripheral motor nerves may be identified.

*Table 2-II. Likely Signs and Symptoms of GB Poisoning Shown in Terms of Vapour Exposure and Approximate Blood Acetylcholinesterase Depression*

Short term Ct mg.min.m <sup>-3</sup>	Approximate AChE depression	Symptoms and signs*	
		Vapour	Systemic exposure only eyes protected
<2	<5%	Incipient miosis (miosis produced at Ct=2, t=30 min), slight headache.	Nil.
5	20% ±10%	Increased miosis, headache, eye pain, rhinorrhoea, conjunctival injection, tightness in chest.	Tightness in chest.
5-15	20-50% ±10%	Eye signs maximal. Bronchospasm in some subjects.	Symptoms beginning to appear. Bronchospasm.
15	50%±10%	Bronchospasm and all the effects already described.	Wheezing, salivation, eye effects, nausea, vomiting. (Local sweating and fasciculation in liquid contamination of the skin.)
40	80%±10%	Symptoms and signs as for systemic exposure.	Weakness, defecation, urination, paralysis, convulsions.
100	100%	Respiratory Failure Death	Respiratory Failure Death

\* All symptoms and signs will be subject to very considerable inter-subject variation.

## SECTION II - EFFECTS OF NERVE AGENTS

### 208. Signs and Symptoms.

- The order in which signs and symptoms appear and their relative severity depend on the route of exposure and whether the casualty has been exposed to liquid agent or vapour.
- The signs and symptoms following exposure to nerve agents are given in Table 2-III.
- The local effects of vapour and liquid exposure are described followed by a description of the systemic effects which occur after significant absorption of agent via any route.

### 209. Effects of Nerve Agent Vapour.

- Absorption.* The lungs and the eyes absorb nerve agents rapidly. Changes occur in the smooth muscle of the eye, resulting in miosis and in the smooth muscle and

secretory glands of the bronchi, producing bronchial constriction and excessive secretions in the upper and lower airways. In high vapour concentrations, the nerve agent is carried from the lungs throughout the circulatory system; widespread systemic effects may appear in less than 1 minute.

*Table 2-III. Signs and Symptoms of Nerve Agent Poisoning*

Site of action	Signs and symptoms
<b>a. Muscarinic.</b>	
(1) Pupils.	Miosis, marked, usually maximal (pin-point), sometimes unequal.
(2) Ciliary body.	Frontal headache, eye pain on focusing, blurring of vision.
(3) Nasal mucous membranes.	Rhinorrhoea, hyperaemia.
(4) Bronchial tree.	Tightness in chest, bronchoconstriction, increased secretion, cough.
(5) Gastrointestinal.	Occasional nausea and vomiting.
<b>b. Muscarinic following systemic absorption (depending on dose).</b>	
(1) Bronchial tree.	Tightness in chest, with prolonged wheezing expiration suggestive of bronchoconstriction or increased secretion, dyspnoea, pain in chest, increased bronchial secretion, cough, cyanosis, pulmonary oedema.
(2) Gastrointestinal.	Anorexia, nausea, vomiting, abdominal cramps, epigastric and substernal tightness (cardiospasm) with "heartburn" and eructation, diarrhoea, tenesmus, involuntary defecation.
(3) Sweat glands.	Increased sweating.
(4) Salivary glands.	Increased salivation.
(5) Lachrymal glands.	Increased lachrymation.
(6) Heart.	Bradycardia.
(7) Pupils.	Miosis, occasionally unequal, later maximal miosis (pin-point).
(8) Ciliary body.	Blurring of vision, headache.
(9) Bladder.	Frequency, involuntary micturition.
<b>c. Nicotinic.</b>	
(1) Striated muscle.	Easy fatigue, mild weakness, muscular twitching, fasciculations, cramps, generalised weakness/flaccid paralysis (including muscles of respiration) with dyspnoea and cyanosis.
(2) Sympathetic ganglia.	Pallor, transitory elevation of blood pressure followed by hypotension.
<b>d. Central nervous system.</b>	
	Immediate (Acute) Effects: Generalised weakness, depression of respiratory and circulatory centres with dyspnoea, cyanosis and hypotension; convulsions, loss of consciousness and coma.
	Delayed (Chronic) Effects: Giddiness, tension, anxiety, jitteriness, restlessness, emotional lability, excessive dreaming, insomnia, nightmares, headaches, tremor, withdrawal and depression, bursts of slow waves of elevated voltage in EEG (especially on hyperventilation), drowsiness, difficulty concentrating, slowness of recall, confusion, slurred speech, ataxia.

**b. Local Ocular Effects.**

- (1) These effects begin within seconds or minutes after exposure, before there is any evidence of systemic absorption. The earliest ocular effect which follows minimal symptomatic exposure to vapour is miosis. This is an invariable sign of ocular exposure to enough vapour to produce symptoms. It is also the last ocular manifestation to disappear. The pupillary constriction may be different in each eye. Within a few minutes after the onset of exposure, there also occurs redness of the eyes due to conjunctival hyperaemia, and a sensation of pressure with heaviness in and behind the eyes. Usually vision is not grossly impaired, although there may be a slight dimness especially in the peripheral fields or when in dim or artificial light.
- (2) Exposure to a level of a nerve agent vapour slightly above the minimal symptomatic dose results in miosis, pain in and behind the eyes attributable to ciliary spasm, especially on focusing, some difficulty of accommodation and frontal headache. The pain becomes worse when the casualty tries to focus the eyes or looks at a bright light. Some twitching of the eyelids may occur. Occasionally there is nausea and vomiting which, in the absence of systemic absorption, may be due to a reflex initiated by the ocular effects. These local effects may result in moderate discomfort and some loss of efficiency but may not necessarily produce casualties.
- (3) Following minimal symptomatic exposure, the miosis lasts from 24 to 72 hours. After exposure to at least the minimal symptomatic dose, miosis is well established within half an hour. Miosis remains marked during the first day after exposure and then diminishes gradually over 2 to 3 days after moderate exposure but may persist for as long as 14 days after severe exposure. The conjunctival erythema, eye pain, and headache may last from 2 to 15 days depending on the dose.

**c. Local Respiratory Effects.** Following minimal exposure, the earliest effects on the respiratory tract are a watery nasal discharge, nasal hyperaemia, sensation of tightness in the chest and occasionally prolonged wheezing expiration suggestive of bronchoconstriction or increased bronchial secretion. The rhinorrhoea usually lasts for several hours after minimal exposure and for about 1 day after more severe exposure. The respiratory symptoms are usually intermittent for several hours duration after mild exposure and may last for 1 or 2 days after more severe exposure.

**210. Effects of Liquid Nerve Agent.**

- a. **Local Ocular Effects.** The local ocular effects are similar to the effects of nerve agent vapour. If the concentration of the liquid nerve agent contaminating the eye is high, the effects will be instantaneous and marked; and, if the exposure of the two eyes is unequal, the local manifestations may be unequal. Hyperaemia may occur but there is no immediate local inflammatory reaction such as may occur following ocular exposure to more irritating substances (for example, Lewisite).
- b. **Local Skin Effects.** Following cutaneous exposure, there is localised sweating at and near the site of exposure and localised muscular twitching and fasciculation.



However, these may not be noticed causing the skin absorption to go undetected until systemic symptoms begin.

- c. *Local Gastrointestinal Effects.* Following the ingestion of substances containing a nerve agent, which is essentially tasteless, the initial symptoms include abdominal cramps, vomiting and diarrhoea.

## 211. Systemic Effects of Nerve Agent Poisoning.

- a. The sequence of symptoms varies with the route of exposure. While respiratory symptoms are generally the first to appear after inhalation of nerve agent vapour, gastrointestinal symptoms are usually the first after ingestion. Following comparable degrees of exposure, respiratory manifestations are most severe after inhalation, and gastrointestinal symptoms may be most severe after ingestion. Otherwise, the systemic manifestations are, in general, similar after any exposure to nerve agent poisoning by any route. If local ocular exposure has not occurred, the ocular manifestations (including miosis) initially may be absent.
- b. The time course of effects following exposure to nerve agents are given in Table 2-IV.
- c. The systemic effects may be considered to be nicotinic, muscarinic or by an action at receptors within the central nervous system. The predominance of muscarinic, nicotinic or central nervous system effects will influence the amount of atropine, oxime or anticonvulsant which must be given as therapy. These effects will be considered separately.

## 212. Muscarinic Effects of Nerve Agent Poisoning.

- a. Tightness in the chest is an early local symptom of respiratory exposure. This symptom progressively increases as the nerve agent is absorbed into the systemic circulation, whatever the route of exposure. After moderate or severe exposure, excessive bronchial and upper airway secretions occur and may become very profuse, causing coughing, airway obstruction and respiratory distress. Audible wheezing may occur, with prolonged expiration and difficulty in moving air into and out of the lungs, due to the increased bronchial secretion or to bronchoconstriction, or both. Some pain may occur in the lower thorax and salivation increases.
- b. Bronchial secretion and salivation may be so profuse that watery secretions run out of the sides of the mouth. The secretions may be thick and tenacious. If postural drainage or suction is not employed, these secretions may add to the airway obstruction. Laryngeal spasm and collapse of the hypopharyngeal musculature may also obstruct the airway. The casualty may gasp for breath, froth at the mouth, and become cyanotic.
- c. If the upper airway becomes obstructed by secretions, laryngeal spasm or hypopharyngeal musculature collapse, or if the bronchial tree becomes obstructed by secretions or bronchoconstriction, little ventilation may occur despite respiratory movements. As hypoxaemia and cyanosis increase, the casualty will fall exhausted and become unconscious.

Table 2-IV. Time Course of Effects of Nerve Agents

Nerve agent	Types of effects	Route of absorption	Description of effects	When effects appear after exposure*	Duration of effects after:	
					Mild exposure	Severe exposure
Vapour.	Local.	Lungs.	Rhinorrhoea, nasal hyperaemia, tightness in chest, wheezing.	One to several minutes.	A few hours.	1 to 2 days.
Vapour.	Local.	Eyes.	Miosis, conjunctival hyperaemia, eye pain, frontal headache.	One to several minutes.	Miosis 24 hours.	2 to 3 days.
Vapour.	Systemic.	Lungs or eyes.	Muscarinic, nicotinic, and central nervous system effects. (See Table 3-1).	Less than one minute to a few minutes after moderate or severe exposure.	Several hours to a day.	Acute effects: 2 to 3 days. CNS effects: days to weeks.
Liquid.	Local.	Eyes.	Same as vapour effects.	Instantly.	Similar to effects of vapour.	
Liquid.	Local.	Ingestion.	Gastrointestinal. (See Table 3-1).	About 30 minutes after ingestion.	Several hours to a day.	2 to 5 days.
Liquid.	Local.	Skin.	Local sweating and muscular twitching.	3 minutes to 2 hours.	3 days.	5 days.
Liquid.	Systemic.	Lungs.	See Table (3-1).	Several minutes.		1 to 5 days.
Liquid.	Systemic.	Eyes.	Same as for vapour.	Several minutes.		2 to 4 days.
Liquid.	Systemic.	Skin.	Generalised sweating.	15 minutes to 2 hours.		2 to 5 days.
Liquid.	Systemic.	Ingestion.	Gastrointestinal. (See Table 3-1).	15 minutes to 2 hours.		3 to 5 days.

\* After lethal or near lethal exposures to nerve agents, the time to onset of symptoms and to maximal severity of symptoms is shorter; it may be extremely brief after overwhelming exposure. Following exposure to lethal concentrations, the time interval to death depends upon the degree, the route of exposure, and the agent. If untreated, exposure to lethal concentrations of nerve agents can result in death 5 minutes after appearance of symptoms.

d. Following inhalation of nerve agent vapour, the respiratory manifestations predominate over the other muscarinic effects: they are likely to be most severe in older casualties and in those with a history of respiratory disease, particularly bronchial asthma. However, if the exposure is not so overwhelming as to cause death within a few minutes, other muscarinic effects appear. These include sweating, anorexia, nausea and epigastric and substernal tightness with heartburn and eructation. If absorption of nerve agent has been great enough (whether due to a single large exposure or to repeated smaller exposures), there may follow abdominal cramps, increased peristalsis, vomiting, diarrhoea, tenesmus, increased lachrymation and urinary frequency. Cardiovascular effects are a bradycardia, hypotension and cardiac arrhythmias. The casualty perspires profusely, may have involuntary defecation and urination and may go into cardiorespiratory arrest followed by death.

**213. Nicotinic Effects.**

- a. With the appearance of moderate muscarinic systemic effects, the casualty begins to have increased fatiguability and mild generalised weakness which is increased by exertion.
- b. This is followed by involuntary muscular twitching, scattered muscular fasciculations and occasional muscle cramps. The skin may be pale due to vasoconstriction and blood pressure moderately elevated (transitory) together with a tachycardia, resulting from cholinergic stimulation of sympathetic ganglia and possibly from the release of epinephrine. If the exposure has been severe, the muscarinic cardiovascular symptoms will dominate and the fascicular twitching (which usually appear first in the eyelids and in the facial and calf muscles) becomes generalised. Many rippling movements are seen under the skin and twitching movements appear in all parts of the body. This is followed by severe generalised muscular weakness, including the muscles of respiration. The respiratory movements become more laboured, shallow and rapid; then they become slow and finally intermittent. Later, respiratory muscle weakness may become profound and contribute to the respiratory depression. Central respiratory depression may be a major cause of respiratory failure.

**214. Central Nervous System Effects.**

- a. In mild exposures, the systemic manifestations of nerve agent poisoning usually include tension, anxiety, jitteriness, restlessness, emotional lability, and giddiness. There may be insomnia or excessive dreaming, occasionally with nightmares.
- b. If the exposure is more marked, the following symptoms may be evident: headache, tremor, drowsiness, difficulty in concentration, impairment of memory with slow recall of recent events, and slowing of reactions. In some casualties there is apathy, withdrawal and depression. With the appearance of moderate symptoms, abnormalities of the electroencephalogram occur, characterised by irregularities in rhythm, variations in potential, and intermittent bursts of abnormally slow waves of elevated voltage similar to those seen in patients with epilepsy. These abnormal waves become more marked after one or more minutes of hyperventilation which, if prolonged, may occasionally precipitate a generalised convulsion.
- c. If absorption of nerve agent has been great enough, the casualty becomes confused and ataxic. The casualty may have changes in speech, consisting of slurring, difficulty in forming words, and multiple repetition of the last syllable. The casualty may then become comatose, reflexes may disappear and respiration may become Cheyne-Stokes in character. Finally, generalised convulsions may ensue.
- d. With the appearance of severe central nervous system symptoms, central respiratory depression will occur (adding to the respiratory embarrassment that may already be present) and may progress to respiratory arrest. However, after severe exposure the casualty may lose consciousness and convulse within a minute without other obvious symptoms. Death is usually due to respiratory arrest and anoxia, and requires prompt initiation of assisted ventilation to prevent death. Depression of the

circulatory centres may also occur, resulting in a marked reduction in heart rate with a fall of blood pressure some time before death.

### **215. Cumulative Effects of Repeated Exposure.**

- a. Daily exposure to concentrations of a nerve agent insufficient to produce symptoms following a single exposure may result in the onset of symptoms after several days. Continued daily exposure may be followed by increasingly severe effects.
- b. After symptoms subside, increased susceptibility may persist for up to 3 months. The degree of exposure required to produce recurrence of symptoms and the severity of these symptoms depend on the dose received and the time interval since the last exposure. Increased susceptibility is not limited to the particular nerve agent initially absorbed.

### **216. Cause of Death.**

- a. In the absence of treatment, death is caused by anoxia resulting from airway obstruction, weakness of the muscles of respiration and central depression of respiration.
- b. Airway obstruction is due to pharyngeal muscular collapse, upper airway and bronchial secretions, bronchial constriction and occasionally laryngospasm and paralysis of the respiratory muscles.
- c. Respiration is shallow, laboured, and rapid and the casualty may gasp and struggle for air. Cyanosis increases. Finally, respiration becomes slow and then ceases. Unconsciousness ensues. The blood pressure (which may have been transiently elevated) falls. Cardiac rhythm may become irregular and death may ensue.
- d. If assisted ventilation is initiated via cricothyroidotomy or endotracheal tube and airway secretions are removed by postural drainage and suction and diminished by the administration of atropine, the individual may survive several lethal doses of a nerve agent. However, if the exposure has been overwhelming, amounting to many times the lethal dose, death may occur despite treatment as a result of respiratory arrest and cardiac arrhythmia.
- e. When overwhelming doses of the agent are absorbed quickly, death occurs rapidly without orderly progression of symptoms.

## **SECTION III - TREATMENT OF NERVE AGENT POISONING**

### **217. Diagnosis and Therapy of Nerve Agent Poisoning.**

- a. *Symptoms.* Nerve agent poisoning may be identified from the characteristic signs and symptoms. If exposure to vapour has occurred, the pupils will be very small, usually pin-pointed. If exposure has been cutaneous or has followed ingestion of a nerve agent in contaminated food or water, the pupils may be normal or, in the presence of severe systemic symptoms, slightly to moderately reduced in size. In this event, the other manifestations of nerve agent poisoning must be relied on to establish the diagnosis. No other known chemical agent produces muscular twitching and

- fasciculations, rapidly developing pin-point pupils, or the characteristic train of muscarinic, nicotinic and central nervous system manifestations.
- b. *Symptom Differentiation.* It is important that individual service members know the following MILD and SEVERE signs and symptoms of nerve agent poisoning. Service members who have most or all of the symptoms listed below must IMMEDIATELY receive first aid (self-aid or buddy aid respectively).
- c. *MILD Poisoning (Self-Aid).* Casualties with MILD symptoms may experience most or all of the following:
- (1) Unexplained runny nose.
  - (2) Unexplained sudden headache.
  - (3) Sudden drooling.
  - (4) Difficulty in seeing (dimness of vision and miosis).
  - (5) Tightness in the chest or difficulty in breathing.
  - (6) Localised sweating and muscular twitching in the area of the contaminated skin.
  - (7) Stomach cramps.
  - (8) Nausea.
  - (9) Bradycardia or tachycardia.
- d. *MODERATE Poisoning.* Casualties with MODERATE poisoning will experience an increase in the severity of most or all of the MILD symptoms. Especially prominent will be an increase in fatigue, weakness and muscle fasciculations. The progress of symptoms from mild to moderate indicates either inadequate treatment or continuing exposure to agent.
- e. *SEVERE Symptoms (Buddy Aid).* Casualties with SEVERE symptoms may experience most or all of the MILD symptoms, plus most or all of the following:
- (1) Strange or confused behaviour.
  - (2) Wheezing, dyspnoea (severe difficulty in breathing), and coughing.
  - (3) Severely pin-pointed pupils.
  - (4) Red eyes with tearing.
  - (5) Vomiting.
  - (6) Severe muscular twitching and general weakness.
  - (7) Involuntary urination and defecation.
  - (8) Convulsions.
  - (9) Unconsciousness.
  - (10) Respiratory failure.
  - (11) Bradycardia.
- f. *Aid for Severe Cases.* Casualties with severe symptoms will not be able to treat themselves and must receive prompt buddy aid and follow-on medical treatment if they are to survive.

## 218. Treatment.

The lethal effects of nerve agent poisoning may be combated by a combination of pretreatment and post exposure therapy.

**219. Pretreatment.**

- a. Poisoning by nerve agents which form rapidly aging complexes (for example Soman) may be particularly difficult to treat. These difficulties have been solved, in part, by the use of carbamates as pretreatment. The terms pretreatment or prophylaxis should perhaps be defined as used in this context:
  - (1) Pretreatment: the administration of drugs in advance of poisoning designed to increase the efficacy of treatment administered post-poisoning.
  - (2) Prophylaxis: the administration of drugs in advance of the poisoning designed to make post-poisoning therapy unnecessary.
- b. The terms are to an extent interchangeable and as, in cases of severe poisoning, post-poisoning therapy is nearly always needed, the term pretreatment will be used here.
- c. Carbamate anticholinesterases, e.g., pyridostigmine, may be used as pretreatment against nerve agent poisoning by virtue of their capacity to bind acetylcholinesterase *reversibly*, preventing the organophosphate (OP) binding to the enzyme. The term reversible is here used comparatively: the carbamate-acetylcholinesterase complex breaks down fairly rapidly, while organophosphate-acetylcholinesterase complexes break down very slowly. The aged soman-acetylcholinesterase complex breaks down virtually not at all.
- d. When carbamates are used as pretreatments, carbamoylation of acetylcholinesterase prevents phosphorylation, but later the carbamate-acetylcholinesterase complex dissociates, freeing active enzyme. Current pretreatment regimes bind 30-40% of available red blood cell acetylcholinesterase, thereby allowing the carbamate to protect some of the acetylcholinesterase against attack by nerve agent.
- e. The carbamate pyridostigmine, given in a dose of 30 mg every 8 hours, is used as a pretreatment. In conjunction with post exposure therapy, good protection against lethality is obtained within 2 hours of the first dose, but is not optimal until the third dose.
- f. Pyridostigmine pretreatment should be stopped upon developing symptoms of nerve agent poisoning following a chemical warfare attack and post exposure therapy started.
- g. Pyridostigmine tablets were taken over a 4 to 5 day period by large numbers of troops during the Gulf War of 1991.
  - (1) The effects of pyridostigmine were examined in several studies including one uncontrolled study of 42,000 troops when, following the recommended dose regime, under the stress of combat conditions, gastrointestinal intestinal changes including increased flatus, loose stools, abdominal cramps and nausea were noted by approximately half the population. Other reported effects were urinary urgency, headache, rhinorrhoea, diaphoresis and tingling of the extremities. These effects were considered tolerable. They did not noticeably interfere with performance of the full range of demanding physical and mental tasks required of service personnel.
  - (2) Symptoms due to pyridostigmine may be ameliorated by taking the tablets with food.
  - (3) Pyridostigmine pretreatment was discontinued on medical advice in less than 0.1 % of individuals, generally because of intolerable nausea and diarrhoea.

- h. When taken in excess of the recommended dosage, symptoms of carbamate poisoning will occur. These include diarrhoea, gastrointestinal cramps, tight chest, nausea, rhinorrhoea, headache and miosis.
- i. Good compliance is required if optimal protection is to be obtained. The importance of pyridostigmine pretreatment should therefore be stressed during training.

## **220. Post-Exposure Therapy.**

The main principles of therapy for nerve agent poisoning are early treatment, assisted ventilation, bronchial suction, muscarinic cholinergic blockade (atropine), enzyme reactivation (oximes) and anticonvulsants (benzodiazepines).

## **221. Emergency Field Therapy.**

### **a. *Self Aid (or Buddy Aid).***

- (1) This comprises first aid measures which the soldier can apply to help him or herself. The rapid action of nerve agents call for immediate self treatment. Unexplained nasal secretion, salivation, tightness of the chest, shortness of breath, constriction of pupils, muscular twitching, or nausea and abdominal cramps call for the immediate intramuscular injection of 2 mg of atropine, combined if possible with oxime. From 1 to 3 automatic injection devices, each containing 2 mg atropine or mixture of atropine, oxime and/or anticonvulsant, are carried by each individual.
- (2) One device should be administered immediately when the symptoms and/or signs of nerve agent poisoning appear. This may be done by the casualty or by a buddy; the injection being given perpendicularly through the clothing into the lateral aspect of the middle of the thigh. Further devices, up to a total of 3, should be administered by the casualty or by his or her buddy during the following 30 minutes if the symptoms and/or signs of poisoning fail to resolve.
- (3) The timing of these further injections and whether they are given at one time or separately may depend on the casualty's condition and on instructions promulgated by individual nations.
- (4) NOTE: If automatic injectors are used in the absence of exposure to agent, the following signs and symptoms may be seen: Dry mouth, dry skin, fast pulse (>90 beats per minute), dilated pupils, retention of urine and central nervous system disturbance. Susceptibility to heat exhaustion or heat stroke is increased, particularly in closed spaces or while wearing protective clothing.

### **b. *First Aid by Trained Personnel.***

- (1) This comprises the emergency actions undertaken to restore or maintain vital bodily functions in a casualty. Wherever the casualty is not masked the respirator must be adjusted for him or her by the nearest available person. Attention should be given to decontamination at the earliest possible moment

and any skin contamination must be removed with a personal decontamination kit.

- (2) After nerve agent poisoning, the administration of atropine is repeated at intervals until signs of atropinization (dry mouth and skin and tachycardia >90 per minute) are achieved. Miosis from vapour exposure is not relieved by systemic atropine.
- (3) Mild atropinization should be maintained for at least 24 hours by intramuscular injection of 1-2 mg of atropine at intervals of ½ to 4 hours, as required. The danger of ventricular arrhythmias arising from atropinization while the casualty is anoxic must be remembered.
- (4) Assisted ventilation is required for severely poisoned individuals as they will have:
  - (a) Marked bronchoconstriction;
  - (b) Copious secretions in the trachea and bronchi;
  - (c) Paralysis of the respiratory muscles; and
  - (d) Central respiratory depression, hypoxia, and convulsions.

**c. Resuscitation.**

- (1) Positive pressure resuscitation should be given but the pressure necessary to overcome the bronchoconstriction may be more than 65 cm of water so that incubation if possible is highly desirable. In an uncontaminated atmosphere assisted ventilation may be done by the standard mouth-to-mouth method after decontamination of the casualty's face and mouth. In a contaminated atmosphere ventilation may be given by a portable resuscitator with NBC filter attached. Both the casualty and the resuscitator should be decontaminated.
- (2) In a well equipped medical facility, mechanical resuscitation of the positive pressure type may be used with endotracheal intubation or tracheostomy-artificial respiration must be continued until the casualty is breathing normally or the medical personnel have pronounced the casualty dead. Due to the production of copious secretions, regular suction will be required.

**222. Pharmacological Treatment of Nerve Agent Poisoning.**

- a. The pharmacological treatment of nerve agent poisoning involves the use of
  - (1) Anticholinergics to antagonise the muscarinic effects (atropine).
  - (2) Oximes to reactivate inhibited enzyme.
  - (3) Anticonvulsants to prevent CNS damage.
- b. The effects of drugs used in nerve agent poisoning are described below.

**223. Atropine.**

- a. Atropine sulphate remains an essential drug in the treatment of nerve agent poisoning. It acts by blocking the effects of acetylcholine at muscarinic receptors and so produces relief from many of the symptoms previously listed. If given in large doses, some therapeutic effects are also produced within the central nervous system



although atropine does not readily penetrate the blood brain barrier and central muscarinic receptors are thought not to be identical with those in the periphery. It is thought to counteract the respiratory depression in the medulla oblongata.

- b. Urgent treatment with atropine in cases of nerve agent poisoning is essential. After the emergency field treatment, atropinisation should be maintained for at least 24 hours by intramuscular injection or slow intravenous infusion of 1 to 2 mg of atropine per hour as required. The dose should be repeated at intervals until signs of successful atropinisation are noted. Intervals of 5 to 15 minutes seem reasonable, but severe poisoning may require higher doses (4 mg to 6 mg per hour or more). Signs of successful atropinisation include the drying up of bronchial, salivary and skin secretions and an increase in heart rate to greater than 90 beats per minute.
- c. The effect of atropine in drying bronchial secretions may make the removal of mucus more difficult so suction is likely to be necessary. In excessive doses, atropine may render the ischaemic myocardium more liable to arrhythmias and electrocardiogram ( ECG) monitoring should be undertaken in all patients if possible.
- d. Atropine overdosage may produce euphoria, hallucinations, anxiety, and delirium and close observation of patients is necessary. Bladder dysfunction may necessitate catheterisation.
- e. By inhibition of sweat production, atropine increases heat stress and in warm or hot weather care must be taken to avoid hyperthermia.
- f. Atropine given parenterally has comparatively little effect on nerve agent induced miosis. The local application of cycloplegics (atropine eye drops) to the eye reduces both the degree of miosis, eye pain and headache. However, expert opinion on the value of atropine containing eye drops in the management of nerve agent induced miosis remains divided. It is believed by some that problems of accommodation may be made worse by the application of the drops and that, overall, little benefit may be produced.
- g. If atropine is administered in the absence of nerve agent poisoning, the following effects may be noted: dryness of the mouth and pharynx, decreased sweating, slight flushing and tachycardia, some hesitancy of micturition, slightly dilated pupils, mild drowsiness, slowness of memory and recall and blurring of near vision. After 2mg these symptoms should not interfere with ordinary activity except in the occasional person, in hot environments or at high work rates. Higher doses, or repeated doses, will produce more marked symptoms which will usually not be totally incapacitating except in warm environments or high work rates. The effects of atropine are fairly prolonged, lasting 3 to 5 hours after one or two injections of 2mg and 12 to 24 hours after marked over-atropinisation.

## 224. Oximes.

### a. *Oximes.*

- (1) While atropine blocks the muscarinic effects of nerve agent poisoning it has little effect upon the nicotinic actions of the agent at the skeletal neuromuscular junction and at the autonomic ganglia.
- (2) Amelioration of the effects of nerve agents at these sites and also at

muscarinic sites can, however, be obtained by reactivation of the inhibited acetylcholinesterase by means of oximes. Oximes, therefore, relieve the clinically important symptom of skeletal neuromuscular blockade. However, they penetrate into the central nervous system poorly, and the simultaneous administration of atropine is therefore still required.

b. *Enzyme Reactivation.*

- (1) The relative potency of different oximes in reactivating acetylcholinesterase inhibited by some nerve agents is given in Table 2-V.
- (2) Dosing schemes for the clinical intravenous use of currently available oximes, as applied in poisoning of humans by organophosphate insecticides, are shown in Table 2-VI. Under field conditions similar doses can be given intramuscularly, but care should be taken to avoid accidental intra-arterial injection. The dose rates given could form the base for the determination of national dosing procedures which should include emergency field treatment.

*Table 2-V. Effectiveness of Various Oximes in the Treatment of Nerve Agent Poisoning*

Oxime	GA	GB	GD	GF
P <sub>2</sub> S	-	+	-	-
Obidoxime	+	+	-	+/-
HI6	+/-	+	+/-	+
+ = Effective		- = Not effective		
+/- = Sometimes effective				

*Table 2-VI. Examples of Current Dosing Scheme for the Intravenous Administration of Oximes*

Degree of poisoning	PAM Cl dose	P <sub>2</sub> S dose	Obidoxime dose
Mild	1 g	400 mg	250 mg
Moderate	1 g*	400 mg**	250 mg***
Severe	1 g*	500 mg**	250 mg***

\* To be repeated every 8 to 12 hours.

\*\* Second dose of 400 mg to 500 mg after 30 minutes. Further doses of 200 mg to 400 mg every 4 to 12 hours.

\*\*\* Second dose after 2 hours. Further doses to be repeated every 6 to 12 hours.

- (3) An alternative method of administering oxime is as a continuous infusion. On the basis of a theoretical therapeutic plasma concentration of  $4\text{mg}\cdot\text{l}^{-1}$ , the loading dose and maintenance dose for intravenous use can be calculated for different oximes using data obtained in healthy human volunteers (Table 2-VII). Data from human organophosphorus insecticide poisoning suggest that these dose rates are also applicable in patients.
  - (4) Clinical experience in human poisoning by organophosphorus insecticide shows that oxime treatment should be continued for some hours after reactivation has been obtained and the patient has recovered. If no enzyme reactivation has been obtained after a 24 to 48 hour period of treatment and the patient has not recovered, then it should be accepted that the enzyme inhibition is resistant to reactivation by the particular oxime and administration should be stopped. There is only limited experience with human poisoning with organophosphorus nerve agents, but animal data suggest that the clinically relevant persistence of nerve agent in the body will probably be shorter than for insecticides. It may be suggested therefore, that oxime treatment should be continued until the recovery of the patient, with a probable maximum duration of 24 to 48 hours.
- c. *Oxime Induced Side Effects.* The rapid injection of pralidoxime 2 (PAM Cl or P<sub>2</sub>S) can produce drowsiness, headache, disturbance of vision, nausea, dizziness, tachycardia and an increase in blood pressure, hyperventilation and muscular weakness. Obidoxime produces hypotension, a menthol-like sensation and a warm feeling in the face. On intramuscular injection, it can produce a dull pain at the site of injection; after multiple dosing, hepatic dysfunction can be observed. HI6 (a type of oximide) produces similar effects.

*Table 2-VII. Loading Doses and Infusion Rates for Oxime Administration to Obtain a Plasma Concentration of  $4\text{mg}\cdot\text{l}^{-1}$*

Oxime	Loading dose** ( $\text{mg}\cdot\text{kg}^{-1}$ )	Approximate dose for 70 kg person (mg)	Infusion rate*** ( $\text{mg}\cdot\text{kg}^{-1}\cdot\text{h}^{-1}$ )	Approximate rate for 70 kg person ( $\text{mg}\cdot\text{h}^{-1}$ )
PAM Cl	4.2	300	2.2	160
P <sub>2</sub> S	4.4	310	2.1	150
Obidoxime	0.8	56	0.5	34
HI6*	1.6	110	0.8	54

\* Based on data from intramuscular administration.  
 \*\* Loading dose = therapeutic plasma concentration x volume of distribution.  
 \*\*\* Infusion rate = therapeutic plasma concentration x clearance.

**225. Anticonvulsants.**

- a. Atropine protects only partially against convulsions and the resulting brain damage in severe poisoning. Complementary treatment, including anticonvulsants, should be applied as necessary.
- b. It has been shown in experimental soman poisoning that diazepam antagonises the convulsive action of soman and that addition of diazepam to the basic treatment regime greatly improves morbidity and mortality, independent of its anticonvulsive effect. Diazepam is the drug of choice and should be injected intramuscularly as a 10 mg dose initially and further doses should be given frequently enough to control convulsions. This may require injections at intervals ranging from a few minutes to several hours.

**226. Supportive Care.**

Although pre and post exposure therapy will protect against lethality, casualties may still be incapacitated. A patient severely poisoned by an anticholinesterase is a critical medical emergency and may require intensive care for days or weeks. Assisted ventilation may be needed for many hours or days and the patient may be comatose for hours or days and brain damage may result from periods of hypoxia. General supportive care such as IV feeding, restoring electrolyte balance, treatment of shock and control of convulsions is needed. Therapy to control infection, should this occur, should be on the usual lines. Special care should be taken using muscle relaxants in patients poisoned by nerve agents.

## CHAPTER 3

## VESICANTS (BLISTER AGENTS)

## SECTION I - MUSTARD AND NITROGEN MUSTARDS

**301. Introduction.**

- a. Blister or vesicant agents are likely to be used both to produce casualties and to force opposing troops to wear full protective equipment thus degrading fighting efficiency, rather than to kill, although exposure to such agents can be fatal. Blister agents can be thickened in order to contaminate terrain, ships, aircraft, vehicles or equipment with a persistent hazard. The vesicant agents include sulphur mustard (HD), nitrogen mustard (HN), the arsenical vesicants such as lewisite (L) (this may well be used in a mixture with HD), and the halogenated oximes whose properties and effects are very different from those of the other vesicants.
- b. Vesicants burn and blister the skin or any other part of the body they contact. They act on the eyes, mucous membranes, lungs, skin and blood-forming organs. They damage the respiratory tract when inhaled and cause vomiting and diarrhoea when ingested.

**302. Mustard Agents.**

- a. Sulphur mustard was used extensively in World War I and has been used in more recent military campaigns. Protection against these agents can only be achieved by a full protective ensemble. The respirator alone protects against eye and lung damage and gives some protection against systemic effects. Extensive, slow healing skin lesions will place a heavy burden on the medical services.
- b. Sulphur mustard is the best known of these agents. Synthesised in 1822, its vesicant properties were discovered in the middle of the nineteenth century. As a chemical agent it was used for the first time in 1917 near Ypres from which it derives its French name (Yperite). Mustard is 2,2' -di(chloro-ethyl)-sulphide. It is also known by the name "Lost" in German.
- c. In the US the symbol HD has been given to the distilled product. In this chapter it will be indicated thus. In 1935 it was discovered that the vesicant properties remained when the sulphur atom was substituted by a nitrogen atom. Thus it became possible to synthesise the nitrogen mustards with similar properties, of which there are three, viz:
  - (1) N-ethyl-2,2' di(chloroethyl)amine, or HN1.
  - (2) N methyl-2,2' di(chloroethyl)amine, or HN2.
  - (3) 2,2',2'' tri(chloroethyl)amine, or HN3.
- d. From a military standpoint, HN3 is the principal representative of the group of nitrogen mustards and is the only nitrogen mustard likely to be used in war.

**303. Physical and Chemical Properties.**

- a. The mustards are able to penetrate cell membranes in tissues and a great number of materials: woods, leather, rubber, plants, etc. Due to their physical properties, mustards are very persistent in cold and temperate climates. It is possible to increase the persistency by dissolving them in non-volatile solvents, e.g., chlorinated rubber. In this way thickened mustards are obtained that are very difficult to remove by decontaminating processes.
- b. In warmer climates persistence of mustards is less but higher concentrations of vapour occur.
- c. When dissolved in water, mustards are hydrolysed at an appreciable rate, yielding poly-alcohols and hydrochloric acid (HCl), so that the solution may still be damaging to the skin. In more concentrated solutions, interaction of products becomes more pronounced and several dimers are formed. In 2 hours 22% of the initial concentration is hydrolysed, in 6 hours 35% and in 24 hours 60%. However, as their volatility in water is very poor, two phases are generally formed and hydrolysis of the undissolved bulk is very slow. In running water the contact surfaces are frequently changed and persistency is only a few days, but in stagnant water, persistency can be several months. Mustard is denser than water, but small droplets remain on the water surface and present a special hazard in contaminated areas. Alkalinity and higher temperatures increase the rate of hydrolysis.
- d. Owing to its bivalent sulphur atom, sulphur mustard has very good reducing properties. Depending on their strengths, oxidants oxidise mustard to a greater or lesser extent, e.g., to sulphoxide, sulfone or sulphate. Of these only the sulfone has appreciable vesicant properties.
- e. Nitrogen mustards are much less easily oxidised than sulphur mustard.

**304. Detection.**

- a. Mustards have the interesting property of forming, under certain conditions, coloured complexes with para-nitrobenzpyridine thus making it possible to detect minute amounts.
- b. Mustard agents can be detected by a variety of means. Single and three colour detector papers will detect liquid agent and are available for individual issue. Monitoring devices for local contamination and water testing kits are also available.

**305. Protection.**

- a. Ordinary clothing gives little or no protection against mustard agents. Special equipment including a respirator, NBC suit, gloves and overboots are required. Due to slow absorption of mustard by many materials, protective equipment must be changed regularly according to the appropriate national drills.
- b. No drug is available for the prevention of the effects of mustard on the skin and the mucous membranes caused by mustards. It is possible to protect the skin against very low doses of mustard by covering it with a paste containing a chlorinating

agent, e.g., chloramine. The only practical prophylactic method is physical protection such as is given by the protective respirator and special clothing.

### 306. Decontamination.

- a. *General.* The decontamination of clothing, equipment, arms, vehicles, materials, buildings and terrain does not come within the framework of this manual. Decontamination of food and drinking water is discussed in Chapter 12. Only the decontamination of the skin, mucous membranes, eyes and wounds is dealt with here. Exposure to mustard is not always noticed immediately because of the latent and sign-free period that may occur after skin exposure. This may result in delayed decontamination or failure to decontaminate at all.
- b. *Decontamination of Mucous Membranes and Eyes.* The substances used for skin decontamination are generally too strongly irritant to be used on mucous membranes and the eyes. In this case the affected tissues should be flushed immediately with water from the water bottle (canteen). The eyes can be flushed with copious amounts of water, or, if available, isotonic sodium bicarbonate (1.26%) or saline (0.9%).
- c. *Decontamination of the Skin.* Each soldier is given the means for a preliminary decontamination of the skin, the means being based on physical adsorption or on the combination of physical adsorption and chemical inactivation. Physical adsorption can be achieved by adsorbing powders. Chemical inactivation is often effected by chlorinating compounds incorporated into adsorbing powders, ointments, solutions or organic solvents. Mustards should not be decontaminated with water, except for the eyes, as this may spread the agent.
- d. *Additional Procedures.* Whatever means is used has to be efficient and quick acting. Within 2 minutes contact time, a drop of mustard on the skin can cause serious damage. Chemical inactivation using chlorination is effective against mustard and Lewisite, less so against HN3, and is ineffective against phosgene oxime. In the case of thickened mustard, where the usual procedure is inadequate, the agent may be scraped off with a knife or similar hard object. This maybe followed by wetting the surface with a cloth drenched in an organic solvent, e.g., petrol (unleaded gasoline) and subsequent application of the usual decontaminating procedure. If water is available in abundant amounts these procedures should be followed by copious washing.
- e. *Decontamination of Wounds.*
  - (1) Mustard may be carried into wounds on fragments of cloth. These wounds should be carefully explored using a no-touch technique. Fragments of cloth should be removed and placed in a bleach solution. This removes the hazard from mustard vapour off-gassing.
  - (2) Wounds should be irrigated using a solution containing 3000-5000 ppm (parts per million) free chlorine (dilute "milton" solution) with a dwell time of approximately 2 minutes. The wound should then be irrigated with saline. Irrigation of the contaminated wound should not be used in the abdominal, or thoracic cavities, nor with intracranial head injuries.

### 307. Mechanism of Action.

- a. Sulphur and nitrogen mustards are bifunctional alkylating agents, containing two reactive chloroethyl functions. Interaction products with cellular components can occur via formation of ethylenesulfonium (sulphur mustards) or ethylenimanium ions (nitrogen mustards) through cyclisation and subsequent binding. (See Figure 3-1.) In deoxyribonucleic acid (DNA), monofunctional adducts are formed predominantly (the second chloroethyl function is converted into hydroxyethyl), but bifunctional binding, leading to formation of cross-links, does occur. (See Figure 3-1.) Also alkylation of ribonucleic acid (RNA), proteins, cellular membrane components and cross-links between DNA and proteins can be the cause of cellular damage. Among the DNA- and RNA-bases guanine is affected most.
- b. The formation of reactive species of sulphur mustard and the interaction with guanine residues in DNA are shown in Figure 3-I.
- c. The binding of reactive sulphur or nitrogen mustard species to DNA produces a range of effects.
  - (1) Due to their relative instability, N7-alkylated guanine residues may be released from the DNA. Upon DNA replication, the remaining apurinic sites do not provide a proper template of information, which results in erroneous incorporation of nucleotides. This may lead to mutations and synthesis of non-functional proteins.
  - (2) In general, the presence of damage to DNA can include cellular repair mechanisms, which are not error-free. These processes thus may also give rise to erroneous DNA replication.
  - (3) Crosslinks, in particular interstrand crosslinks, for example between two guanines (as shown in Figure 3-I), may play an important role in the cytotoxicity of the sulphur and nitrogen mustards. They inhibit the DNA replication process when they are not properly repaired.

### 308. Toxicity.

- a. HD and HN3 are the most feared vesicants historically, because of their chemical stability, their persistency in the field, the insidious character of their effects by attacking skin as well as eyes and respiratory tract, and because no effective therapy is yet available for countering their effects. Since 1917, mustard has continued to worry military personnel with the many problems it poses in the fields of protection, decontamination and treatment. It should be noted that the ease with which mustard can be manufactured and its great possibilities for acting as a vapour would suggest that in a possible future chemical war HD will be preferred to HN3.
- b. Three distinct levels of biological action can be discerned following exposure to mustards: cytostatic, mutagenic and cytotoxic effects. In the present state of knowledge one cannot rule out the possibility that some effects might be due to reactions with cellular membranes or critical enzymes. The actions of mustards resembling those produced by ionising radiations and mustards have been called radiomimetic compounds.



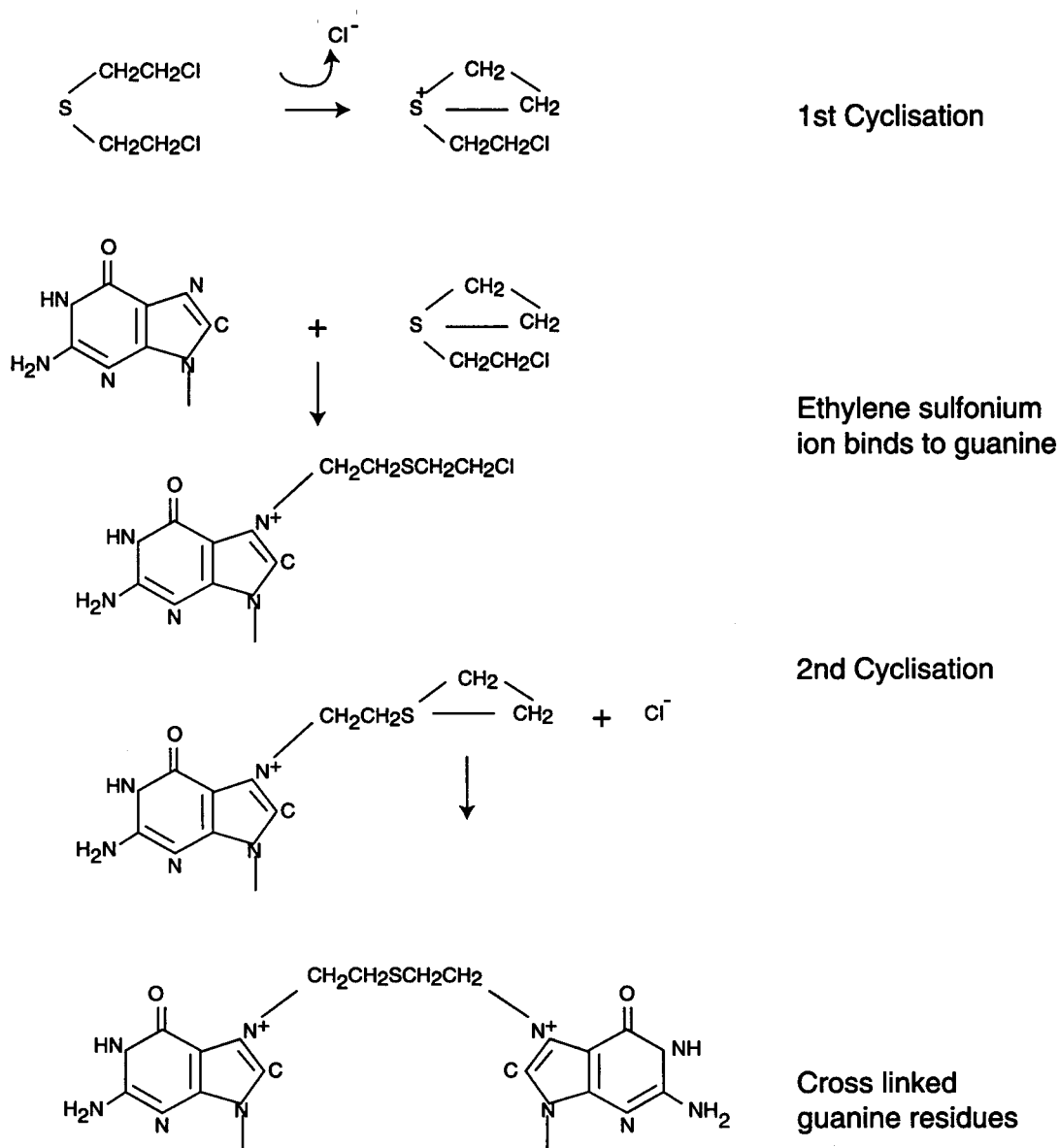


Figure 3-1. Formation of Reactive Sulphur Mustard and Interaction with Guanine in DNA

- c. Actively proliferating cells are affected most; thus basal epidermal cells, the haemopoietic system and the mucosal lining of the intestine are particularly vulnerable.

## SECTION II - CLINICAL-PATHOLOGICAL EFFECTS

### 309. Eyes.

- a. In a single exposure the eyes are more susceptible to mustard than either the respiratory tract or the skin. Conjunctivitis follows exposure of about 1 hour to

concentrations barely perceptible by odour. This exposure does not effect the respiratory tract significantly. A latent period of 4 to 12 hours follows mild exposure, after which there is lachrymation and a sensation of grit in the eyes. The conjunctival and the lids become red and oedematous. Heavy exposure irritates the eyes after 1 to 3 hours and produces severe lesions. Mustard burns of the eyes may be divided as follows:

- (1) Mild conjunctivitis (75% of cases in World War 1). Recovery takes 1 to 2 weeks.
  - (2) Severe conjunctivitis with minimal corneal involvement (15% of cases in World War 1). Blepharospasm, oedema of the lids and conjunctival occur, as may orange-peel roughening of the cornea. Recovery takes 2 to 5 weeks.
  - (3) Mild corneal involvement (10% of cases in World War 1). Areas of corneal erosion stain green with fluorescein dyes. Superficial corneal scarring and vascularisation occurs as does iritis. Temporary relapses occur and convalescence may take 2 to 3 months. Hospital care is indicated for casualties of this type.
  - (4) Severe corneal involvement (about 0.1% of World War 1 mustard casualties). Ischaemic necrosis of the conjunctival may be seen. Dense corneal opacification with deep ulceration and vascularisation occurs. Convalescence may take several months and patients are predisposed to late relapses.
- b. Although temporary blindness may occur, permanent blindness is very rare. Casualties should therefore be reassured and a positive attitude taken.
  - c. Care must be exercised to avoid transferring liquid agent from the hands to the eyes.

### 310. Skin.

- a. The hallmark of sulphur mustard exposure is the occurrence of a latent symptom and sign free period of some hours post exposure. The duration of this period and the severity of the lesions is dependent upon the mode of exposure, environmental temperature and probably on the individual himself. High temperature and wet skin are associated with more severe lesions and shorter latent periods. Some people are markedly more sensitive to mustard than others. Burns may be the result of either vapour or liquid exposure.
- b. The sequence of skin changes normally seen is as follows:
  - (1) *Erythema (2-48 hour post exposure)*. This may be very striking and reminiscent of scarlet fever. Slight oedema of the skin may occur. Itching is common and may be intense. As the erythema fades areas of increased pigmentation are left. (This sequence is reminiscent of that seen in sun burn.)
  - (2) *Blistering*. Blisters are not, per se, painful, though they may be uncomfortable and feel tense. Blisters at points of flexure, anterior aspects of elbows and posterior aspects of knees, can seriously impede movement. Mustard blisters are delicate and may be easily ruptured by contact with bed linen, bandages or during transport of casualties. Crops of new blisters may appear as late as the second week post exposure. Blister fluid is not dangerous and does not produce secondary blistering if applied to skin.

- (3) *Deep burning leading to full thickness skin loss.* This is particularly likely to occur on the penis and scrotum.
- c. Lesions tend to be painful and some patients complain of very severe pain. Healing of skin lesions is slow. The areas which were markedly erythematous darken and may become very hyperpigmented. Brownish-purple to black discoloration of some areas may occur. These changes tend to disappear over a period of several weeks with desquamation leading to the appearance of areas of hypopigmentation. The appearance of such areas alongside those of hyperpigmentation may be striking.
- d. The sensitivity of the skin depends on its thickness and upon the density of sweat and sebaceous glands. Apart from mucous membranes the most sensitive areas are the face, armpits, genitalia, neck, skin between the fingers and the nail beds. The palm of the hand, sole of the foot and the skin of the scalp are very resistant. If only a small dose is applied to the skin the effect is limited to erythema and after several days the colour changes from red to brown. The itch diminishes progressively and the epidermis desquamates. At higher doses blister formation starts, generally between 4 and 24 hours after contact, and this blistering can go on for several days before reaching its maximum. They are often more than 1 cm<sup>2</sup> and maybe very large and pendulous. Their domes, which are thin and yellowish, contain a relatively clear or slightly yellow liquid. The blisters are fragile and usually rupture spontaneously giving way to a suppurating and necrotic wound. The necrosis of the epidermal cells is extended to the underlying tissues, especially to the dermis. The damaged tissues are covered with slough and are extremely susceptible to infection. The regeneration of these tissues is very slow, taking from several weeks to several months, much longer than the time required for the restoration of skin destroyed by physical means or by caustic compounds. Healing may result in contractures, scarring and fragile skin which may be easily damaged by trauma.

### **311. Respiratory Tract.**

Mustard attacks all the mucous membranes of the respiratory tract. After a latent period of 4 to 6 hours, it irritates and congests the mucous membranes of the nasal cavity and the throat, as well as the epitheliums of the trachea and large bronchi. Symptoms start with rhinorrhoea, burning pain in the throat and hoarseness of the voice. This pain may make the patient reluctant to cough. A dry cough gives way to copious expectoration. The vocal cords often become damaged, resulting in aphonia. Airway secretions and fragments of necrotic epitheliums may obstruct the lungs; rales and reduced air entry can be detected by auscultation. There is pronounced dyspnoea. The damaged lower airways become infected easily, predisposing to bronchopneumonia after approximately 48 hours. If the inhaled dose has been sufficiently high the victim dies in a few days, either from pulmonary oedema or mechanical asphyxia due to fragments of necrotic tissue obstructing the trachea or bronchi, or from superimposed bacterial infection, facilitated by an impaired immune response.

**312. Bone Marrow.**

Mustard agents may cause a general depletion of all elements of the bone marrow. The cells of the granulocyte series and megacaryocytes appear more susceptible to damage than those of the erythropoietic system. A reactive leukocytosis may occur during the first three days, followed by a decrease in the peripheral white cell count. The development of a severe leukopenia or an aplastic anaemia indicates a poor prognosis.

**313. Gastrointestinal Tract.**

Ingestion of contaminated food or water may cause destruction of mucous membranes. Symptoms include nausea, vomiting, pain, diarrhoea and prostration. These features may make casualties reluctant to eat. Vomit and faeces may be bloodstained. Shock may occur.

**314. Systemic Action.**

Systemically absorbed mustards by any route, including severe skin exposure, may cause signs similar to those of irradiation, such as headache, nausea, vomiting, leucopenia and anaemia. Gastrointestinal pain commonly occurs. Absorption of high doses may result in CNS excitation leading to convulsions, followed by CNS depression. Cardiac irregularities may occur with atrio-ventricular block and cardiac arrest may follow.

**SECTION III -TREATMENT OF MUSTARD LESIONS****315. Prophylaxis.**

There is no practical drug treatment available for preventing the effects of mustard.

**316. Therapy.**

- a. There is no specific treatment available for the treatment of mustard lesions.
- b. The aim of therapy is to:
  - (1) Relieve symptoms.
  - (2) Prevent infections.
  - (3) Promote healing.

**317. Eye Lesions.**

- a. The effects of mustard on the eyes are very painful. Use of local analgesics may increase corneal damage and are not recommended. Systemic analgesics (narcotics) should therefore be used as required. Secondary infection is a serious complication and increases the amount of corneal scarring. To prevent infection treat with appropriate anti-bacterial preparations. When the lesion proves more serious (blistering of the eyelids, blepharospasm, etc.), continue application of the anti-

bacterial preparation at more frequent intervals. Patients with corneal lesion should receive mydriatics to prevent adhesions between the iris and cornea. In case of troublesome secretions accumulating, the eyes may be carefully irrigated with a 0.9% sterile saline solution and sterile petroleum jelly (Vaseline™) may be applied to the eyelids to prevent sticking. Do not cover the eyes with a bandage, but, if necessary, protect them with dark or opaque goggles. When the eyelids can be separated without too much pain examine the cornea for possible lesions with fluorescein solution followed by lavage: a green spot indicates a lesion, which, when severe should be treated by an ophthalmologist as soon as possible. In some countries ophthalmologists have recommended controversial treatments including the use of citrate and ascorbate eye drops and regular topical steroids.

- b. More severe injuries will cause enough oedema of the lids, photophobia and blepharospasm to obstruct vision. This alarms the patients. To allay their fears, the lids may be gently forced open to assure them that they are not blind.
- c. Although temporary blindness may occur, permanent blindness is very rare. Casualties should therefore be reassured and a positive attitude taken.

### **318. Skin Lesions.**

- a. It is important to ensure that no remaining contamination is present before commencing treatment.
- b. The skin turns red and itches intensely. This itching can be diminished by local applications of cooling preparations, e.g., calamine lotion, corticosteroids in solution, or even water. Ointments and creams are not advised for microbiological reasons. Severe erythema around the genitalia may become quite painful and associated weeping and maceration may ensue. Often, treatment with exposure of the area is desirable and care must be taken so that secondary infection of tissue does not occur.
- c. Infection is the most important complicating factor in the healing of mustard burns. There is no consensus on the need to de-roof blisters or on the optimum form of treatment (open or covered, dry or wet). Once blisters have broken, it is best to remove its ragged roof to decrease the possibility of secondary infection. Routine wound inspection aids in the early detection and institution of appropriate therapy for any complicating bacterial infections. Analgesics should be given as required. Skin grafting is rarely required and when it has been attempted, grafts have not taken well. The use of cytokines is undergoing further research.
- d. In a recent review on the casualties from the Iran-Iraq conflict, it appeared that the healing process and the final outcome were more dependent on the severity of the initial lesion than on the treatment applied.

### **319. Respiratory Tract Lesions.**

Mild respiratory tract injury, with hoarseness and sore throat only, usually requires no treatment. Cough may be relieved by codeine. Laryngitis and tracheitis may be treated symptomatically with steam or sterile cool mist inhalations. If more severe respiratory tract

injury is suspected, hospitalisation may be advisable. If a bacterial pneumonia occurs, isolation of the specific organisms with their antibiotic sensitivities should be performed, then antibiotic therapy can be limited to the specific agents.

### **320. Systemic Effects.**

- a. Every effort should be made to maintain adequate metabolic status and to replace loss of fluids and electrolytes. Infection should be treated promptly and vigorously. The use of growth factors is the subject of ongoing research.
- b. It has been suggested by some authorities that sodium thiosulphate will prevent or reduce systemic damage from mustard, provided that it can be given intravenously within 20 minutes of exposure. Its efficacy is very doubtful if given later.

### **321. Burns Caused by High Doses of Vapour.**

After exposure to a high dose of mustard vapour, especially under tropical conditions, nausea, vomiting and symptoms of collapse are usually evident before erythema develops completely. It is important to note that this occurs also among personnel who are masked during exposure. Constitutional symptoms may persist several days, during which burns will increase in severity. Cases of this type should be classed as casualties. Severe vapour burns of the trunk produce a generalised erythema but include pale grey areas that eventually vesicate or become necrotic. It is common to see patches of unaffected skin as a result of protection by overlying equipment.

### **322. Burns Caused by Low Doses of Vapour.**

Mild vapour burns cause erythema, itching, and irritation but do not produce casualties. The medical officer should always consider the interval after exposure in relation to the severity of the burn. Mild lesions may represent early phases of severe exposure to vapour. When the period since exposure is uncertain, rapidity of development and the presence of constitutional symptoms may help to determine the severity.

### **323. Sensitisation Due to Multiple Exposures to Mustard.**

- a. Attention should be paid to the characteristic appearance of "re-exposure" burns. This manifestation may occur in individuals as a result of exposure to mustard 1 to 3 weeks (or more) previously. A small percentage of men and women will become sensitised to the agent and will react differently, both qualitatively and quantitatively, upon re-exposure. Sensitisation will be followed by a more rapid onset of symptoms upon re-exposure. Erythema, with or without oedema, and pronounced itching and burning usually appear within 1 hour. Lower concentrations of mustard may produce effects in a sensitised person than in a non-sensitised person. When erythema and oedema result from exposure to a low dose, they generally develop rapidly and subside within 2 to 3 days. Also, vesication resolves

more rapidly in the sensitised individual.

- b. One of the most frequent manifestations of re-exposure in sensitised individuals is the development of a morbilliform rash. Another characteristic reaction is the appearance of eczematoid dermatitis surrounding old lesions, whether or not they are healed. This may last for several days and resembles dermatitis venenata (from poison ivy). Similar phenomena due to sensitisation have been known to occur with the nitrogen mustards.

### 324. Disposition of Casualties.

- a. Evaluation of lesions that have most generally led to disability of personnel exposed to blister agents during field trials and who subsequently participated in simulated combat exercises, obstacle course tests and marches, resulted in the following observations:
  - (1) Widespread vesication of the trunk produced casualties.
  - (2) Vesication localised in particular areas of the body produced casualties.
  - (3) Burns caused by high doses of the vapour to masked personnel, especially in tropical climates, are of casualty severity partly due to oedema and vesication of the skin and partly to constitutional reactions such as nausea, vomiting and prostration.
  - (4) Burns produced by doses of vapour low enough to cause only such skin reactions as mild erythema, oedema, burning and itching usually do not produce casualties.
  - (5) The stage of development of the lesion must be considered when classifying an individual as a casualty or non-casualty.
- b. The effects of mustard on particular areas of the body are explained below.

### 325. Trunk and Neck.

#### *a. Extensive Vesication of the Trunk.*

- (1) All the patients considered under this heading should be evacuated promptly. Extensive vesication may occur over a large part of the trunk. Intervening areas of skin may be erythematous with pin-point vesication. These burns are more likely to occur on the back than anteriorly.
- (2) Some protection is afforded anteriorly by equipment such as webbing and ammunition pouches. The front of the uniform also gives some anterior protection because it does not cling to the body.
- (3) Extensive vesication may be followed by fever, nausea and vomiting.
- (4) These effects tend to occur more readily in tropical climates.
- (5) Secondary bacterial infection may complicate the clinical course. The medical officer in a forward position is not likely to see infection of vesicated areas because such cases will have been evacuated before secondary infection develops.

#### *b. Localised Vesication of the Trunk.*

- (1) Vesication occurring within the natal cleft (between the buttocks) usually requires evacuation of the casualty. Walking becomes difficult, defecation is

painful and dressings require frequent changing. The lesion is usually most intense at the upper end of the cleft. Vesication of the buttocks usually results from sitting on contaminated ground or in contaminated trousers for prolonged periods. The vesicated area may extend forward across the perineum to involve the scrotum and the penis.

- (2) Trivial burns, such as mild erythema affecting the natal cleft, are not of casualty severity. However, these burns require careful attention because walking or running aggravates the lesions and may break down injured skin.
- (3) Single discrete blisters on the buttocks away from the natal cleft do not produce casualties.
- (4) Blisters on the trunk generally require protective dressings to prevent friction due to clothing. The medical officer must decide whether dressings should remain in position during regular duty.

### **326. Arms.**

- a. Most individuals with blister agent injuries of the arms, when suitably treated, are permitted to continue with their duties. Vesication, when localised produces little or no disability.
- b. Extensive vesication involving the axillae and the elbows, volar or dorsal aspects, partially impairs the movement of the limbs at those joints. Oedema of the surrounding tissue tends further to immobilise the extremities. The dorsal aspects of the elbow and forearm are common sites of severe burns because these parts touch contaminated ground when men and women are firing in the prone position. Casualties of this type should be evacuated.
- c. Widespread vesication of the arms results in partial disability. Casualties of this type should be evacuated.

### **327. Hands.**

- a. Blister agent burns of the hands are often encountered. These burns tend to cause a degree of disability out of proportion to the size of the lesions. Considerable care and judgement are required in correct disposition.
- b. Experience in tropical experimental installations indicates that protective gloves and protective ointment provide adequate protection against high doses of vapour. Yet it is hard to avoid burns of the hands in a heavily contaminated jungle. The palms are more resistant to vesication but blisters affecting the palms are characteristically painful and slow to heal.
- c. A solitary lesion of limited extent may result in little or no disability if treated properly.
- d. Burns from liquid vesicant on the dorsum of the hand result in severe local reactions characterised by intense oedema of the backs of the hands and fingers. Pain is characteristic and is intensified by movement of the fingers or wrist. These patients should be regarded as casualties. An individual exposed within the previous 24 hours and reporting for treatment with apparently trivial blisters may be totally incapacitated the following day. Sharp erythema of the dorsum of the hand, with



vesication beginning 12 to 24 hours after exposure, indicates a lesion that will progress to extensive vesication and oedema. Under such circumstances the individual should be evacuated when first seen.

- e. More commonly, the lesions consist of scattered small vesicles and limited areas of erythema. These lesions can be protected satisfactorily and the individuals returned to duty.
- f. Exposure to vesicant vapour produces diffuse erythema of the dorsum of the hand and wrist. Higher doses cause oedema and vesication as well; patients of this type require evacuation.

### **328. Lower Extremities.**

- a. When the lower extremities are involved, the knees are the most common sites of burns from liquid vesicant. These lesions and those of the ankles often result in incapacitation by interfering with locomotion. Movement of joints tends to aggravate existing lesions by increasing oedema. A further disabling factor is introduced by the wearing of firm dressings applied to mobile joints.
- b. Vesication often spreads over the kneecaps, upward onto the thighs, and down toward the feet. These burns tend to be extensive and are associated with oedema often extending halfway up the thigh and down the leg. Medical officers should evacuate casualties with such lesions.
- c. In general, burns of the leg are more incapacitating than burns of the thigh.
- d. It has been shown that the presence of many superficial blisters on the legs and thighs alone is not enough to make an individual incapable of carrying out routine military duties. Individuals with such lesions, having suitable dressings, were able to take part in daily marches and routine gun drills. In disposing of these cases, the medical officer will consider the mental and physical status of the individual, his or her willingness to carry on, and the tactical situation at the time. Such patients are in the category of partial disability. After suitable dressings have been applied, individuals with high morale and robust physiques may be returned to duty.
- e. A relatively small blister or group of blisters situated in the popliteal area may reduce the efficiency of a man or woman so much that he or she may require evacuation. This is due to aggravation of the lesions by movement of the limbs and interference with ambulation. However, blisters affecting this area are not necessarily casualty-producing. (Inflammation, oedema, infection and lesions on other parts of the body should be considered when deciding upon the disposition of an individual). Available evidence indicates that the mustard blister, size for size, is potentially more incapacitating than a blister from lewisite. This results from the tendency of mustard blisters to be associated with erythema and oedema, while the lewisite blister usually causes little local reaction.
- f. Vesicant lesions also develop near the ankles at the tops of the shoes. Blistered areas occurring at such unprotected points are associated with severe pain due to circulatory impairment and tense oedema of the leg. These patients should be evacuated.
- g. Vapour burns of the legs tend to be most aggravated in the popliteal spaces. Pin-point

vesication is often found here. Higher doses cause intense erythema with scattered areas of vesication over the entire surface of the leg. Such lesions are invariably casualty producing and are generally accompanied by severe burns elsewhere, frequently with severe systemic effects.

- h. Mild vapour burns of the legs produce irritation and itching common to all widespread vapours burns. While these effects are troublesome, they are not casualty producing, and men or women so affected maybe returned to duty.
- i. Extensive vesication of the feet is uncommon. The soles are protected by shoes and are comparatively resistant to vesication. Burns on the dorsal aspect of the foot are often associated with local reactions like those seen on the backs of hands. Individuals with these burns, especially if widespread over the foot, find it difficult or impossible to wear shoes and will require evacuation. Small discrete blisters may be of non-casualty significance. These blisters may be effectively protected so as to allow wearing of shoes and walking with little discomfort.

### 329. Genitalia.

- a. The genital region, in addition to the eyes and the respiratory tract, is highly sensitive to blister agent burns. In World War I such burns produced many casualties. The majority of these burns were caused by vapour. Despite present methods of protection against blister agents, including impregnated garments designed to protect the genitalia, medical officers (especially in tropical areas) may be confronted with many casualties with such burns.
- b. Vapour is a more common cause of burns affecting the male genitalia than liquid agent. Erythema may not be conspicuous. The most prominent feature of the burn is the oedema involving the penis and scrotum. Fluid accumulates most readily in the prepuce, distending its entire circumference and forming a characteristic semitranslucent ring around the cornea. In more severe cases the entire body of the penis becomes oedematous.
- c. The lesions cause apprehension as well as physical discomfort. Occasionally vesication is superimposed on the oedema. Ulceration is not infrequent at the tip of the prepuce where it may become secondarily infected. In severe cases associated with marked oedema, retention of urine may result from both mechanical and reflex effects.
- d. In mild cases, objective changes of the scrotum often tend to pass undetected due to the normal pigmentation, elasticity, and looseness of the skin. Even considerable oedema may not be enough to reveal its presence. In severe cases the scrotum may become grossly enlarged. The rugae may be partly or completely obliterated. Pin-point vesication may occur, usually after a lapse of a few days. The scrotal skin tends to breakdown resulting in small painful ulcers and fissures.
- e. Burning is the most prominent subjective symptom in involvement of the genitalia. Apprehension and anxiety are distressing during the presence of the objective changes described above. As oedema decreases, itching starts and may persist long after the acute effects have subsided. Sometimes this itching is intolerable. The scrotum may continue to crack and ulcerate for a considerable period, causing pain and irritation.

- f. Mild exposure of the genital region characteristically is followed by a delay in the development of symptoms, often for as long as 4 to 10 days.
- g. Patients with mild burns without oedema or vesication, but who complain of irritation and burning, may be safely returned to duty following treatment. In disposing of mild burns of the genitalia, the medical officer must assure himself that the symptoms are not too early to be judged with finality. Severely affected individuals should be evacuated on the basis of the apprehension that may be suffered as well as the physical discomfort involved.

### **330. Systemic Effects of Cutaneous Burns.**

- a. Systemic effects due to blister agents probably may be encountered with disabling skin lesions and lesions of the respiratory tract. The medical officer should be familiar with the signs and symptoms. These include anorexia, nausea, vomiting, depression and fever and are far more prone to occur in hot than in temperate climates. Malaise and nausea generally are the first reactions and may then progress either to mild, transient vomiting or to severe, persistent vomiting and retching. Anorexia may be the only complaint in mild reactions. The actual time of onset of symptoms is 4 to 12 hours after exposure and symptoms often occur before skin injury is manifest. No rule can be given for the duration of systemic symptoms, although men or women usually have recovered from severe vomiting within 24 to 26 hours. Anorexia and nausea may persist for a longer time.
- b. The temperature may remain elevated for several days. Mental depression may follow mustard burns and persist for several days.
- c. People with systemic reactions will generally be casualties, particularly in view of the probability of associated extensive skin burns. Such casualties should be evacuated quickly.

### **331. Secondary Bacterial Infection in Blister Agent Burns.**

- a. This paragraph considers the problem of secondary bacterial infection after blister agent injuries only as it influences the disposition of affected personnel in forward positions.
- b. Secondary bacterial infection has often been cited as a common complication of mustard burns of the skin. Compared with the incidence of infection in thermal and traumatic wounds, indications are that the incidence of sepsis in mustard lesions is remarkably low according to observations made at experimental installations.
- c. Secondary infection becomes manifest several days after injury. Medical officers are not likely to see secondary infection with extensive blister agent burns in the front lines because severely affected patients should have been evacuated early.
- d. Infection of small lesions does not require evacuation. Infection of multiple lesions is likely to be an indication for evacuation, particularly if constitutional effects are associated. Infection is particularly disabling when it involves the feet, the hands, the genitalia or tissues overlying the joints of the limbs.
- e. Secondary infection is more likely to occur in severe, rather than mild, vapour injury

- to the respiratory tract. Severe respiratory symptoms will almost invariably be associated with severe eye effects. Respiratory lesions may not develop for several days, and by then the individual should have been evacuated as an eye casualty.
- f. Secondary infection is uncommon as a sequel to mild degrees of mustard conjunctivitis and ordinarily would not prevent an individual from continuing duty.
  - g. Mild conjunctival burns maybe associated with pharyngitis, laryngitis, and tracheitis, increasing in severity for several days. Occasionally more extensive respiratory infection may ensue.

### 332. Course and Prognosis.

As has already been stated, the great majority of mustard gas casualties survive. Resolution of specific problems can be difficult to predict but the following may provide a guide.

- a. *Eye lesions:* Most are resolved within 14 days of exposure.
- b. *Skin lesions:* Deep skin lesions maybe expected to heal in up to 60 days. Superficial lesions heal in 14-21 days.
- c. *Upper respiratory tract lesions:* It is very difficult to define a time course for complete recovery. Recent experience with patients from the Iran-Iraq conflict during 1984-86 was that they were often discharged whilst still coughing and complaining of expectoration. Lung function tests on patients with purely upper respiratory tract lesions were usually normal on discharge. Patients with parenchymal damage often showed an abnormal pattern on lung function testing.

### 333. Long Term Effects of Mustard Gas Poisoning.

The long term effects of mustard maybe divided into three groups:

- a. Personnel exposed to mustard agents may experience prolonged psychological manifestations including chronic depression, loss of libido and anxiety.
- b. Local effects of mustard exposure may include:
  - (1) Visual impairment (permanent blindness is extremely rare).
  - (2) Scarring of the skin.
  - (3) Chronic bronchitis.
  - (4) Bronchial stenosis.
  - (5) Increased sensitivity to mustard gas.
- c. Sulphur mustard is a known carcinogen. A follow up study of American soldiers exposed to sulphur mustard during World War I revealed an increased incidence of lung cancer (and chronic bronchitis) as compared with soldiers who had sustained other injuries. A study of British workers involved in the production of sulphur mustard during World War II revealed no increase in deaths due to cancer amongst those who had died since 1945, but an increase in the prevalence of laryngeal carcinoma amongst those still alive.

## SECTION IV - ARSENICAL VESICANTS - LEWISITE

**334. Introduction.**

The arsines possessing the  $-AsCl_2$  group are endowed with vesicant properties. Of these lewisite is the best known and the most characteristic. Initially preparations contained considerable impurities, but at the end of World War I it was purified in the US, without having been used on the battlefield. Lewisite is 2-chlorovinyl-dichloroarsine,  $ClCH=CH-AsCl_2$ .

**335. Physical and Chemical Properties.**

- a. *Physical Properties.* In a pure form lewisite is a colorless and odourless liquid, but usually contains small amounts of impurities that give it a brownish colour and an odour resembling geranium oil. It is heavier than mustard, poorly soluble in water but soluble in organic solvents. The physical properties are shown in Table 3-I.
- b. *Chemical Properties.* In contact with water lewisite is hydrolyses at an appreciable rate, forming an oxide that is equally vesicant, according to the reaction:  $ClCH=CH-AsCl_2 + H_2O \rightarrow ClCH=CH-AsO + 2HCl$ . In contact with strong alkalis lewisite is totally decomposed to non-vesicant products. Lewisite is very sensitive to oxidants due to the trivalent arsenic atom.

**336. Detection.**

The detection of lewisite is facilitated by the fact that it forms coloured products with many reagents. Draeger™ tubes are available which react with organic arsenical. However, no automatic detectors are available for use in the field.

**337. Protection.**

Ordinary clothing gives little or no protection against lewisite. Special equipment including a respirator, NBC suit, gloves and overboots are required.

**338. Decontamination.**

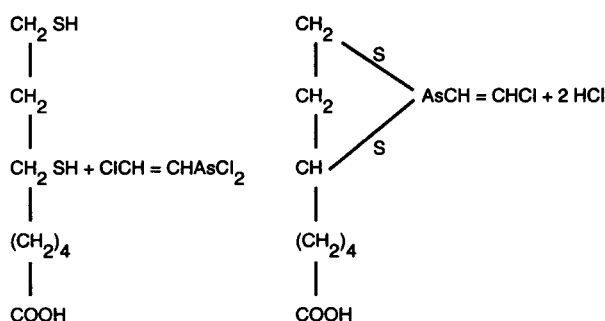
Decontamination is the same as for mustard.

Table 3-1. Physical Properties of Vesicants

Property	Sulphur mustard	Nitrogen mustard	Lewisite	Mustard/lewisite mix	Phosgene oxime
Appearance	Colourless to light yellow liquid, giving off a colourless vapour	Dark coloured liquid giving off a colourless vapour	Dark oily liquid giving off a colourless vapour	Dark oily liquid giving off a colourless vapour	White solid or yellow-brown liquid
Chemical formula	$  \begin{array}{c}  \text{H} & \text{H} & \text{H} & \text{H} \\    &   &   &   \\  \text{Cl}-\text{C}-\text{C}-\text{S}-\text{C}-\text{C}-\text{Cl} \\    &   &   &   \\  \text{H} & \text{H} & \text{H} & \text{H}  \end{array}  $	$  \begin{array}{c}  \text{CH}_2\text{CH}_2\text{Cl} \\  \diagdown \\  \text{N} \\  \diagup \\  \text{CH}_2\text{CH}_2\text{Cl} \\  \text{CH}_2\text{CH}_2\text{Cl}  \end{array}  $	$  \begin{array}{c}  \text{H} & \text{Cl} \\    &   \\  \text{H}-\text{C}=\text{C}-\text{As}-\text{Cl} \\    &   \\  \text{Cl} & \text{H}  \end{array}  $		$  \begin{array}{c}  \text{Cl} & & \text{H} \\  & \diagdown & / \\  & \text{C}=\text{N}-\text{O}- & \\  & / & \diagdown \\  \text{Cl} & &  \end{array}  $
Molecular weight	159.1	204.5	207.35	Not applicable	113.9
Density (g.cm <sup>-3</sup> )	1.27 (25°C)	1.24 (25°C)	1.89 (20°C)	1.66 (20°C)	
Melting point	14.5 °C	-3.7°C	-8 to 0.1°C (diff. purity)	-24.4°C	39 to 43°C
Boiling point	217.0 °C	256.0°C	190.0°C	190.0°C	129.0°C
Vapour density	5.4	7.1	7.1	6.5	3.94
Vapour pressure (mmHg)	0.072 (°20C)	0.011	0.087 (0°C) 0.394 (20°C)	0.02 (-10°C) 0.248 (20°C) 1.03 (40°C)	3.6 (20°C)
Volatility (mg.m <sup>-3</sup> )	75 (0°C) 610 (20°C) 2860 (40°C)	13 (0°C) 121 (25°C) 390 (40°C)	1060 (0°C) 4480 (20°C) 8260 (30°C)	240 (-11°C) 2730 (20°C) 10270 (40°C)	20,000 (20°C) 60,000 (35°C)

**339. Mechanism of Action.**

- a. Due to its physical and chemical properties, lewisite can easily penetrate the skin, where it exerts its vesicant action. It can spread through the whole body and act as an arsenical poison. It has been shown that lewisite inhibits a great number of SH (percentage saturation of hemoglobin) group containing enzymes. Inhibition of the pyruvate dehydrogenase system is a property common to all trivalent arsenic compounds.
- b. Lipoic acid is an essential part of the pyruvate dehydrogenase system, acting as a co-enzyme in the formation of acetyl-Co-A from pyruvate. Lewisite is thought to combine with lipoic acid to form a cyclic compound, thereby interfering with energy production within the cell (Figure 3-II).



*Figure 3-II. Formulation of Cyclic Compound From Lewisite*

## SECTION V - CLINICAL-PATHOLOGICAL EFFECTS

**340. Eyes.**

Liquid arsenical vesicants cause severe damage to the eye. On contact, pain and blepharospasm occur instantly. Oedema of the conjunctival and lids follow rapidly and close the eye within an hour. Inflammation of the iris usually is evident by this time. After a few hours, the oedema of the lids begins to subside, while haziness of the cornea develops and iritis increases. The corneal injury, which varies with the severity of the exposure, may heal without residual effects, induce pannus formation, or progress to massive necrosis. The iritis may subside without permanent impairment of vision, if the exposure was mild. After heavy exposure, hypopyon may ensue, terminating in necrosis, depigmentation of the iris and synechia formation. Liquid arsenical vesicants instantly produce a grey scarring of the cornea, like an acid burn, at the point of contact. Necrosis and sloughing of both bulbar and palpebral conjunctival may follow very heavy exposure. All injured eyes are susceptible to secondary infection. Mild conjunctivitis due to arsenical vesicants heals in a few days without specific treatment. Severe exposure may cause permanent injury or blindness.

### 341. Skin.

- a. *Pathology.* Liquid arsenical vesicants produce more severe lesions of the skin than liquid mustard. Contamination of the skin is followed shortly by erythema, then by vesication which tends to cover the entire area of erythema. The surrounding halo of erythema is less noticeable than with mustard blisters, although the two are often indistinguishable. Microscopically, the blister roof is slightly thicker than the mustard blister roof, consisting of almost the complete thickness of the epidermis and showing more complete coagulation necrosis and less disintegrative necrosis than that of the mustard blister. The yellowish blister fluid is slightly more opaque than that of the mustard blister and microscopically, contains more inflammatory cells. It contains a trace of arsenic but is non-toxic and non-vesicant. There is deeper injury to the connective tissue and muscle, greater vascular damage, and more severe inflammatory reaction than is exhibited in mustard burns. In large, deep, arsenical vesicant burns, there may be considerable necrosis of tissue, gangrene and slough.
- b. *Symptoms.* Stinging pain is felt usually in 10 to 20 seconds after contact with liquid arsenical vesicants. The pain increases in severity with penetration and in a few minutes becomes a deep, aching pain. Pain on contact with liquid arsenical vesicants usually gives sufficient warning so that decontamination may be begun promptly and deep burns thus avoided in conscious victims. After about 5 minutes of contact, there appears a grey area of dead epitheliums resembling that seen in corrosive burns. Erythema is like that caused by mustard but is accompanied by more pain. Itching and irritation persist for only about 24 hours whether or not a blister develops. Blisters are often well developed in 12 hours and are painful at first, in contrast to the relatively painless mustard blister. After 48 to 72 hours, the pain lessens.

### 342. Respiratory Tract.

The vapours of arsenical vesicants are so irritating to the respiratory tract that conscious casualties will immediately put on a mask to avoid the vapour. No severe respiratory injuries are likely to occur except among the wounded who cannot put on masks and the careless, who are caught without masks. The respiratory lesions are similar to those produced by mustard except that in the most severe cases, pulmonary oedema may be accompanied by pleural effusion.

### 343. Systemic Effects.

Liquid arsenical vesicants on the skin, as well as inhaled vapour, are absorbed and may cause systemic poisoning. A manifestation of this is a change in capillary permeability, which permits loss of sufficient fluid from the bloodstream to cause haemoconcentration, shock and death. In non-fatal cases, haemolysis of erythrocytes has occurred with a resultant haemolytic anaemia. The excretion of oxidised products into the bile by the liver produces focal necrosis of that organ, necrosis of the mucosa of the biliary passages with peribiliary hemorrhages and some



injury of the intestinal mucosa. Acute systemic poisoning from large skin burns causes pulmonary oedema, diarrhoea, restlessness, weakness, subnormal temperature and low blood pressure.

## SECTION VI - TREATMENT OF LEWISITE LESIONS

### 344. General.

An antidote for lewisite is dimercaprol (2, 3-dimercapto-propanol,  $\text{CH}_2\text{SH} - \text{CHSH} - \text{CH}_2\text{OH}$ , BAL (British Anti Lewisite)). Purified dimercaprol is a colorless liquid, soluble 1 part in 15 parts of water and more soluble in peanut oil or in ethanol. It can combine with arsenic forming a water soluble complex that can be excreted. With arsenical, the complex formed possesses a pentagon with two carbon atoms, two sulphur atoms and one arsenic atom at the comers. This is the same mechanism by which lewisite blocks two adjacent SH groups of pyruvate dehydrogenase system. The therapeutic action of dimercaprol can thus be explained by the law of mass action: dimercaprol provides the organism with a great number of adjacent SH groups that displaces the arsenic bound to enzymes. The enzymes are reactivated and can resume their normal biological activity. However, the toxicity of dimercaprol itself must be considered. It sometimes provokes local irritation.

### 345. Eyes.

- a. Dimercaprol eye ointment may diminish the effects of lewisite if applied within 2 minutes of exposure. Its value is questionable if applied later than this.
- b. In severe cases, the systemic use of morphine may be necessary for control of pain. When the conjunctival oedema subsides enough to permit ophthalmic examination, the cornea should be stained with fluorescein to detect erosions and the iris should be examined for iritis. Atropine sulphate ointment should be instilled to obtain and maintain good mydriasis in all cases with corneal erosions, iritis cyclitis or with marked photophobia or miosis. Antibiotics may be used to combat infection. Sterile petroleum jelly (Vaseline™) applied to the lid margins will help prevent their sticking together. Irrigations of the eye should be sparing, employing isotonic solutions. Occlusive dressings or pressure on the globe must be avoided.

### 346. Skin.

- a. Dimercaprol (British Anti-Lewisite (BAL)) ointment may be applied to skin exposed to lewisite before actual vesication has begun. Any protective ointment already on the skin must be removed before application of BAL ointment because it may destroy the latter. BAL ointment is spread on the skin in a thin film and allowed to remain at least 5 minutes. Occasionally, BAL ointment causes stinging, itching or urticarial weals. This condition lasts only an hour or so and should not cause alarm. Mild dermatitis may occur if BAL ointment is frequently applied on the same area of skin; hence, this property precludes its use as a protective ointment. Dimercaprol is chemically incompatible with silver sulphadiazine and the two should not be used together.
- b. Some blistering is inevitable in most arsenical vesicant cases which come to the

Medical Services. The treatment of the erythema, blisters and denuded areas is identical with that for similar mustard lesions. A severe third degree burn involving a large surface area is similar to a thermal injury and must be managed by intravenous resuscitation to correct potential hypovolaemic shock. Morphine and splinting of the affected parts may be necessary to relieve pain. When the involved area is greater than 20% of the body surface area, hospitalisation is indicated. Hospitalisation may be indicated when the involved area is less than 20% when the depth of the skin involvement appears to be significant.

### **347. Systemic.**

burns severe enough to cause shock and systemic poisoning are life-threatening. Even if the patient survives the acute effects, the prognosis must be guarded for several weeks.

### **348. Indication for Systemic Treatment.**

The indications for systemic treatment, following exposure to arsenical blister agents by any route are:

- a. Cough with dyspnoea and frothy sputum, which may be blood tinged and other signs of pulmonary oedema.
- b. A skin burn the size of the palm of the hand or larger, caused by a liquid arsenical blister agent which was not decontaminated within the first 15 minutes.
- c. Skin contamination by a liquid arsenical vesicant covering 5% or more of the body surface, in which there is evidence of immediate skin damage (grey or dead-white blanching of the skin), or in which erythema develops over the area within 30 minutes.

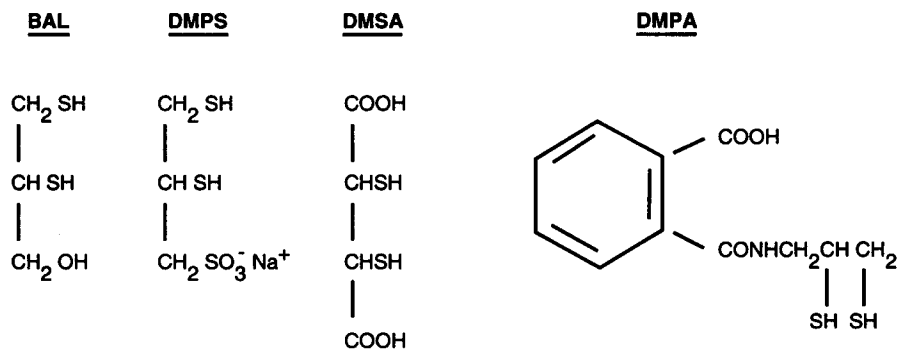
### **349. Types of Treatment.**

- a. The following two types of treatment may be used:
  - (1) Local neutralisation on and within the skin by a liberal application of dimercaprol (BAL) ointment. The affected skin is to be left covered with a layer of ointment. Remove any other protective ointment before treatment with BAL ointment.
  - (2) Intramuscular injection of BAL in oil (10%).
- b. The maximum dosage of BAL is as follows. 3 mg.kg<sup>-1</sup> (200 mg for an average person) intramuscularly repeated every 4 hours for 2 days, every 6 hours on the third day and every 12 hours for up to 10 days. The injection must be by deep intramuscular injection; subcutaneous leakage must be avoided.
- c. Dimercaprol when given by injection often produces alarming reactions including:
  - (1) Increased systolic and diastolic pressure.
  - (2) Tachycardia.
  - (3) Nausea and vomiting.
  - (4) Headache.
  - (5) Burning sensation of lips.
  - (6) Feeling of constriction of the chest.

- (7) Conjunctivitis.
  - (8) Lachrymation.
  - (9) Rhinorrhoea.
  - (10) Sweating.
  - (11) Anxiety and unrest.
- d. Despite these effects “the cure is not worse than the disease” and they pass in a few hours. About 50% of patients will experience such adverse reactions if 5 mg.kg<sup>-1</sup> doses of dimercaprol are given.
- e. Unless unduly severe or prolonged they do not contra-indicate the full course of treatment.

### 350. Therapy.

- a. Dimercaprol is the current therapy for lewisite poisoning. Newer chelating agents, however, have been developed and some look promising for systemic use.
- b. The abbreviations used in this paragraph are as follows:
- (1) DMSA (meso-dimercaptosuccinic acid).
  - (2) DMPS (2,3-dimercapto-1-propanesulfonic acid).
  - (3) Na (salt).
  - (4) DMPA (N-(2,3-dimercaptopropyl)-phthalamidic acid).
- c. Their formulae and that of dimercaprol are shown in Figure 3-III.
- d. The advantages of these compounds include:
- (1) They are water soluble, active when given orally and relatively non-toxic.
  - (2) They are substantially more effective systemically, using the therapeutic index as a measure.
  - (3) BAL produces mobilisation of arsenic from most tissues (for brain see (4)) but is less effective in so doing than DMSA, DMPS and DMPA.
  - (4) BAL given to rabbits poisoned with sodium arsenite produced an increase in brain arsenic levels. DMPA and DMPS on the other hand produced a marked fall in brain arsenic levels.
  - (5) DMSA and DMPS have been identified as having an anti-lewisite action.
  - (6) Of the series DMPS, DMSA and BAL when tested for capacity to reverse or prevent pyruvate dehydrogenase inhibition by sodium arsenite, DMPS proved the most potent and BAL the least potent drug.
- e. The evidence then appears to support the contention that the more recently developed chelating agents should be considered as alternatives to dimercaprol in the treatment of systemic lewisite poisoning. Detailed metabolic studies have not yet been performed on DMSA and DMPS and there is an urgent need for such work.



*Figure 3-III. Formulae for Lewisite Antidotes*

### 351. Course and Prognosis.

The long term effects of exposure to lewisite are unknown.

## SECTION VII - HALOGENATED OXIMES

### 352. Introduction.

The urticant properties of the halogenated oximes were discovered long before World War II. To this group belong diiodofomoxime, dibromofomoxime, monochlorofomoxime and dichlorofomoxime. The last mentioned oxime is the most irritant of the series; it is commonly known as phosgene oxime, symbolised by CX. Its chemical formula is  $\text{CCl}_2 = \text{NOH}$ .

### 353. Physical and Chemical Properties of Phosgene Oxime.

Phosgene oxime is a white crystalline powder. It melts between 39 - 40°C, and boils at 129°C. By the addition of certain compounds it is possible to liquify phosgene oxime at room temperature. It is fairly soluble in water and in organic solvents. In aqueous solution phosgene oxime is hydrolyses fairly rapidly, especially in the presence of alkali. It has a high vapour pressure, its odour is very unpleasant and irritating. Even as a dry solid, phosgene oxime decomposes spontaneously and has to be stored at low temperatures.

### 354. Detection.

The characteristic signs and symptoms of phosgene oxime exposure may suggest its use. There are no automatic detectors available for use in the field.

**355. Protection.**

Ordinary clothing gives little or no protection against phosgene oxime. Special equipment including a respirator, NBC suit, gloves and overboot are required.

**356. Decontamination.**

Chemical inactivation using alkalis is effective, whereas chlorination is ineffective against phosgene oxime. The eyes should be flushed immediately using water or isotonic sodium bicarbonate solution if available. Physical decontamination of the skin using adsorbent powders, e.g., fullers' earth, is advised.

**357. Mechanism of Action.**

In low concentrations, phosgene oxime severely irritates the eyes and respiratory organs. In high concentrations, it also attacks the skin. A few milligrams applied to the skin cause severe irritation, intense pain, and subsequently a necrotising wound. Very few compounds are as painful and destructive to the tissues. Systemic toxicity has been described from parenteral absorption. The exact mode of action is not known. The effects are said to be caused by phosgene oxime reacting with SH and H<sub>2</sub>N groups.

**358. Clinical-Pathological Effects.**

Phosgene oxime also affects the eyes, causing corneal lesions and blindness and may affect the respiratory tract causing pulmonary oedema. The action on the skin is immediate: phosgene oxime provokes irritation resembling that caused by a stinging nettle. A few milligrams cause intense pain which radiates from the point of application, within a minute the affected area turns white and is surrounded by a zone of erythema which resembles a wagon wheel in appearance. In 1 hour the area becomes swollen and within 24 hours the lesion turns yellow and blisters appear. Some days later the area shows desquamation with necrosis of the skin followed by crust formation and a purulent discharge.

**359. Treatment.**

Treat as any other ulcerated necrotic skin lesion (e.g., thermal burn) with due consideration of other supportive measures. Pulmonary oedema should be treated appropriately.

**360. Course and Prognosis.**

Recovery takes 1 to 3 months.

## CHAPTER 4

## LUNG DAMAGING AGENTS (CHOKING AGENTS)

## SECTION I - GENERAL

**401. Introduction.***a. Definition.*

(1) Chemical agents which attack lung tissue, primarily causing pulmonary oedema, are classed as lung damaging agents. To this group belong phosgene (CG), diphosgene (DP), chlorine (Cl) and chloropicrin (PS). Certain other substances, while, not likely to be used as agents, are still likely to be met with on the battlefield (e.g., nitrous fumes and zinc chloride smoke in an undeliquesced state) and may have a similar action.

(2) Similar substances encountered in fires, e.g., perfluoroisobutylene (PFIB) and HCl may also induce lung damage.

*b. Phosgene.* The toxic action of phosgene is typical of a certain group of lung damaging agents. Phosgene is the most dangerous member of this group and the only one considered likely to be used in the future. Phosgene was used for the first time in 1915, and it accounted for 80% of all chemical fatalities during World War I.

## SECTION II - PHOSGENE

**402. Physical and Chemical Properties.**

Phosgene is a colorless gas under ordinary conditions of temperature and pressure. Its boiling point is 8.2°C, making it an extremely volatile and non-persistent agent. Its vapour density is 3.4 times that of air. It may therefore remain for long periods of time in trenches and other low lying areas. In low concentrations it has a smell resembling new mown hay. Phosgene is readily soluble in organic solvents and fatty oils. In water, phosgene is rapidly hydrolyses with the formation of hydrochloric acid and carbon dioxide. Its physical properties are shown in Table 4-I.

**403. Detection.**

There are no automatic detectors available for use in the field.

**404. Protection.**

The respirator gives adequate protection against this agent.

Table 4-1. Physical Properties of Lung Damaging Agents

Property	Phosgene (CG)		Diphosgene (DP)	
Appearance	Colourless gas		Colourless gas	
Chemical formula	COCl <sub>2</sub>		ClCOOCCl <sub>3</sub>	
Molecular weight	98.2		197.9	
Density (g.cm <sup>-3</sup> )	1.38	(20°C)	1.65	(20°C)
Melting point	-128.0°C		-57°C	
Boiling point	7.6°C		127°C	
Vapour density	3.4		6.8	
Vapour pressure (mmhg)	365	(-10°C)	1.0	(0°C)
	555	(0°C)	4.2	(20°C)
	1173	(20°C)		
Volatility (mg.m <sup>-3</sup> )	528,000	(-40°C)	12,000	(0°C)
	2,200,000	(-10°C)	45,000	(20°C)
	4,300,000	(7.6°C)	270,000	(52°C)

#### 405. Decontamination.

Because of its physical and chemical properties, the agent will not remain in its liquid form for long, and decontamination is not required except when it is used in very cold climates.

#### 406. Mechanism of Action.

- a. The mode of action is still not fully understood. It has been suggested that phosgene may act by inhibiting enzymes, or by producing HCl in the alveoli. It has more recently been suggested that phosgene, which is itself a highly reactive molecule, may react directly and instantaneously at the alveolar and capillary wall, permitting plasma to flood the alveoli. Its effects usually reach a maximum 12-24 hours after exposure.
- b. Whatever the mechanism of action, phosgene increases the permeability of the alveolar capillaries with resultant pulmonary oedema. This interferes with pulmonary gaseous exchange, leading to hypoxia. The loss of fluid into the alveoli also results in haemoconcentration which, together with hypoxia, causes cardiac embarrassment which may proceed to cardiac failure.

#### 407. Clinical-Pathological Effects.

The outstanding feature of phosgene poisoning is massive pulmonary oedema. This is preceded by damage to the bronchiolar epitheliums, development of patchy areas of emphysema, partial atelectasis, and oedema of the perivascular connective tissue. The trachea and bronchi are usually normal in appearance. This contrasts with the findings in chlorine and chloropicrin poisoning in which both structures may show serious damage to the epithelial lining with desquamation. The lungs are large, oedematous and darkly congested. Oedema fluid, usually frothy, pours from the bronchi and may be seen escaping from the mouth and nostrils. With exposure to very high concentrations death may occur within several hours; in most fatal cases pulmonary oedema reaches a maximum in 12 hours followed by death in 24-48 hours. If the casualty survives, resolution commences within 48 hours and, in the absence of complicating infection, there may be little or no residual damage.

#### 408. Signs and Symptoms.

During and immediately after exposure, there is likely to be coughing, choking, a feeling of tightness in the chest, nausea, and occasionally vomiting, headache and lachrymation. The presence or absence of these symptoms is of little value in immediate prognosis. Some patients with severe coughs fail to develop serious lung injury, while others with little sign of early respiratory tract irritation develop fatal pulmonary oedema. There maybe an initial slowing of the pulse, followed by an increase in rate. A period follows during which abnormal chest signs are absent and the patient may be symptom-free. This interval commonly lasts 2 to 24 hours but may be shorter. It is terminated by the signs and symptoms of pulmonary oedema. These begin with cough (occasionally substernally painful), dyspnoea, rapid shallow breathing and cyanosis. Nausea and vomiting may appear. As the oedema progresses, discomfort, apprehension and dyspnoea increase and frothy sputum develops. Rales and rhonchi are audible over the chest, and breath sounds are diminished. The patient may develop shock-like symptoms, with pale, clammy skin, low blood pressure and feeble, rapid heartbeat.

#### 409. Treatment.

- a. *Rest and Warmth.* It is desirable that a casualty exposed to a lung-damaging agent be kept at rest until the danger of pulmonary oedema is past, but the operational situation may prevent this. Tightness of the chest and coughing should be treated with immediate rest and comfortable warmth. The casualty should be evacuated in a semi-seated position if dyspnoea or orthopnoea make a supine posture impractical. Mandatory evacuation by litter in cases of significant respiratory involvement has been advocated.
- b. *Sedation.* Sedation should be used sparingly. Codeine in doses of 30 to 60 mg may be effective for cough. Restlessness may be a manifestation of hypoxia; therefore, only cautious use of sedatives is advised. Use of sedatives should be withheld until adequate oxygenation is assured and facilities for possible respiratory assistance are available. Barbiturates, atropine, analeptics and antihistamines are all contraindicated.



- c. *Oxygen.* Hypoxaemia may be controlled by oxygen supplementation. Early administration of positive airway pressure intermittent positive pressure breathing (IPPB), positive end-expiratory pressure (PEEP) mask ("PEEP mask") or, if necessary, incubation with or without a ventilator) may delay and/or minimise the pulmonary oedema and reduce the degree of hypoxaemia.
- d. *Antibiotics.* Antimicrobial therapy should be reserved for acquired bacterial bronchitis/pneumonitis. Prophylactic therapy is not indicated.
- e. *Steroids.* After exposure to a sufficiently high dose of phosgene or similar agent, pulmonary oedema will follow. Administration of corticosteroids has been recommended, but proof of their beneficial effects is lacking. It has been suggested that, when steroid treatment is initiated within a very short time of the exposure, this therapy may lessen the severity of the oedema. Two inhalational regimes are in use: one using dexamethasone and the other using betamethasone or beclomethasone. In either case, treatment should be started as soon as possible, ideally within 15 minutes of exposure. Doses of steroids used are much greater than those prescribed in asthma and when steroids are used they should be given in high doses by inhalation and in severe cases by injection.
- f. *Other.* Rest, warmth, sedation and oxygen are of great importance, as indicated above. Treatment for exposure to a lung-damaging agent, or similar compound, except for zinc chloride smoke, for which an extended regimen is essential, should be judged on the basis of:
  - (1) Precautionary treatment for what seems a mild but possibly dangerous exposure; and
  - (2) Definitive treatment for an exposure which is definitely expected to endanger life.

#### **410. Course and Prognosis.**

During the acute phase, casualties may have minimal signs and symptoms and the prognosis should be guarded. Casualties may very rapidly develop severe pulmonary oedema. If casualties survive more than 48 hours they usually recover without sequelae.

## CHAPTER 5

## CYANOGEN AGENTS (BLOOD AGENTS)

## SECTION I - GENERAL

## 501. Introduction.

- a. Cyanogen agents produce their effects by interfering with oxygen utilisation at the cellular level. Inhalation is the usual route of entry.
- b. The term "blood agents" has, in the past, been used to describe "cyanogen agents." It should be noted however, that not all "blood agents" are cyanogens (e.g., carbon monoxide) and that cyanogens are not necessarily "blood agents."
- c. In this chapter only hydrogen cyanide, (HCN, (AC)) and those agents that derive their toxicity primarily from the liberation of the CN-group in the organism will be discussed, but it should be noted that hydrogen sulphide, H<sub>2</sub>S has a toxicity comparable with HCN and appears to act by a similar mechanism. Only HCN itself and the four cyanogen halides are likely to be of military interest. The cyanogen halides owe their toxicity to the CN-group, but the halogen moiety supplies them with their irritant properties. The most important of the cyanogen halides is cyanogen chloride (CK). During World War I hydrogen cyanide and cyanogen chloride were used and cyanogen bromide to a limited extent.

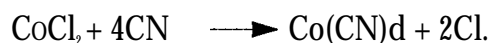
## SECTION II - HYDROGEN CYANIDE

## 502. Properties.

- a. *Physical Properties.* Hydrogen cyanide is a colorless, highly volatile liquid and represents a non-persistent hazard. The vapour is less dense than air and has a faint odour, somewhat like bitter almonds, although about 25% of people are unable to smell this. It is highly soluble and stable in water. (See Table 5-I.)
- b. *Chemical Properties.*
  - (1) The CN compounds hydrolyse slowly in water with subsequent gradual loss of toxicity. They are readily oxidised by strong oxidants, e.g., potassium permanganate.
  - (2) Hydrogen cyanide has an affinity for oxygen and is flammable; hence it is less efficient when dispersed by artillery shells. Compounds which contain labile sulphur atoms (R-S=S<sup>2</sup>) react with HCN even in vivo, for example:



and metal ions easily form complex compounds, for example:



- c. *Usage.* Use is made of this property in some forms of therapy. Hydrogen cyanide, because of its volatility and low molecular weight, is poorly absorbed by the charcoal in the canister of the respirator. This charcoal is therefore impregnated with metal salts in order to improve the performance of the canister, but the protection provided against HCN is not unlimited.

### **503. Detection.**

Automatic detectors are available which detect attack concentrations of cyanide vapour. Draeger™ tubes are also available, as are water testing kits.

### **504. Protection.**

Specialist equipment including a respirator, NBC suit, gloves and overboots give good protection. Modern NBC filters are effective against attack with hydrogen cyanide, but should be changed immediately afterwards.

### **505. Decontamination.**

Because of its physical properties the agent will not remain for long in its liquid state. Decontamination should not, therefore, be necessary.

### **506. Mechanism of Action.**

The cyanide ion forms a reversible complex with the respiratory cytochrome oxidase enzyme system, an enzyme system essential for oxidative processes within cells. This results in impairment of cellular oxygen utilisation. The central nervous system, particularly the respiratory centre, is especially susceptible to this effect and respiratory failure is the usual cause of death.

### **507. Signs and Symptoms.**

- a. The more rapidly the tissue cyanide levels build up, the more acute are the signs and symptoms of poisoning and the smaller is the total absorbed dose required to produce a given effect.
- b. In high concentrations there is an increase in the depth of respiration within a few seconds. This stimulation may be so powerful that a casualty cannot voluntarily hold his or her breath. Violent convulsions occur after 20 to 30 seconds with cessation of respiration within 1 minute. Cardiac failure follows within a few minutes.
- c. With lower concentrations, the early symptoms are weakness of the legs, vertigo, nausea and headache. These may be followed by convulsions and coma which may last for hours or days depending on the duration of exposure to the agent. If coma is prolonged, recovery may disclose residual damage to the central nervous system manifested by irrationality, altered reflexes and unsteady gait which may last for several weeks or longer; temporary or permanent nerve deafness has also been

described. In mild cases there may be headache, vertigo and nausea for several hours before complete recovery.

#### 508. Treatment.

- a. Successful treatment for acute cyanide poisoning depends upon rapid fixation of the cyanide ion, either by methaemoglobin (metHB) formation or by fixation with cobalt compounds.
- b. Any casualty who is fully conscious and breathing normally more than 5 minutes after presumed exposure to cyanide agents has ceased will recover spontaneously and does not require treatment, cyanide being very rapidly detoxified in the body.
- c. Artificial resuscitation, though possible, is not likely to be helpful in the absence of drug treatment.

#### 509. Case Management.

Management of cases of hydrogen cyanide poisoning divides into two parts:

- a. *First Aid Measures.* The casualty should be removed from the source of hydrogen cyanide. Rescue workers should wear adequate individual protective equipment (IPE).
- b. *Therapy.* The key to treatment of patients poisoned with hydrogen cyanide is speed. Though disagreement regarding the ideal drugs for use in the treatment still occurs there is none regarding the need for urgent action.

#### 510. Treatment Approaches.

- a. Two major approaches are involved in the treatment of cyanide poisoning:
  - (1) Provision of binding sites for the cyanide ions. These sites provide alternatives to those of cytochrome oxidase and essentially reactivate that enzyme. Binding sites may be provided by drugs such as dicobalt edetate and by hydroxocobalamin or by the production of methaemoglobin in the blood. Methaemoglobin binds avidly to cyanide ions and may be produced by compounds such as sodium nitrite and amyl nitrite and dimethylarninophenol. Methaemoglobin forming compounds should be used cautiously in patients suffering from concurrent carbon monoxide poisoning or hypoxia.
  - (2) Provision of additional sulphur groups to enhance the detoxification of cyanide and thiocyanate by endogenous rhodanese. This is accomplished by giving sodium thiosulphate.
- b. It is generally agreed that binding the cyanide ions is the first priority of treatment but that thiosulphate must be provided to permit conversion of the cyanide ions to thiocyanate.

#### 511. Drugs That Bind Cyanide Ions.

- a. *Compounds Producing Methaemoglobin.*
  - (1) *Amyl Nitrite.* Amyl nitrite is useful only in a closed positive pressure

respiratory system. Crushing the ampoule around the face or even inside the facepiece of the respirator is inadequate. It should not be used with concurrent oxygen administration due to the risk of explosion. Treatment with amyl nitrite should be followed by sodium thiosulphate.

(2) *Sodium Nitrite.*

(a) Sodium nitrite should be administered intravenously. Ten millilitres of a 3% solution (300 mg) of sodium nitrite should be injected intravenously over a period of 3 minutes. The therapeutic index of sodium nitrate is very low; the above dose, indicated for adults has caused death in children. The sodium nitrite is given to produce methaemoglobin, thus sequestering the cyanide on the methaemoglobin. The cyanide is then removed from the body as thiocyanate after administration of sodium thiosulphate.

(b) The decrease in blood pressure following sodium nitrite injections is negligible unless the patient is allowed to get into an upright position. The development of a slight degree of cyanosis is evidence of a desirable degree of methaemoglobin formation (methaemoglobinaemia). It is not anticipated that at the above dosages an extreme or injurious degree of methaemoglobinaemia will develop. If it does, however, it should be treated by oxygen administration.

(3) *4-Dimethylaminophenol-hydrochloride (DMAP).*

(a) 4-Dimethylaminophenol-hydrochloride (DMAP) has proved very effective in the treatment of cyanide poisoning owing to rapid formation of methaemoglobin. DMAP can be life saving, but not curative; intravenous thiosulphate is required for definitive cure. DMAP should be slowly injected intravenously in a dose of 250 mg. Muscular necrosis may follow intramuscular injection and the intramuscular route should be avoided.

(b) If sodium thiosulphate is not immediately available 250 mg of DMAP should be given every hour until thiosulphate can be given; this latter completes the treatment.

(c) It should be remembered that DMAP will cause cyanosis due to methaemoglobin formation. This indicates effective treatment and does not call for resuscitation. Where too much methaemoglobin has been formed, methylene blue may be given to convert methaemoglobin to hemoglobin (Hb).

b. *Hydroxocobalamin.* Hydroxocobalamin (vitamin B12a) binds cyanide to form cyanocobalamin (vitamin B12). It must be given intravenously in large doses and it is not feasible to give it via any other route.

c. *Dicobalt Edetate.* Dicobalt edetate given intravenously in doses of 600 mg (40 ml of a 1.5% solution in glucose/water solution) has proved successful. The injection should be followed by an intravenous injection of sodium thiosulphate. It should be noted that cobalt edetate is toxic to the kidney and causes hypotension.

## 512. Provision of Sulphur Groups.

Sodium thiosulphate provides additional thiosulphate ions and these combine with cyanide ions under the influence of rhodanese to produce thiocyanate. It should be given to

supplement any other form of treatment for cyanide poisoning. The dose is 12.5 grams intravenously (50 millilitres of a 50% solution) over a 10 minute period.

### **513. Additional Therapy.**

Oxygen should be given if available.

### **514. Course and Prognosis.**

- a. Death may occur within minutes without treatment, but a casualty who is fully conscious and breathing normally 5 minutes after presumed exposure has ceased does not require treatment.
- b. Occasionally, where tissue hypoxia has been prolonged, residual injury of the CNS may persist for weeks and some damage may be permanent.

## **SECTION III - CYANOGEN HALIDES**

### **515. Introduction.**

Cyanogen chloride and cyanogen bromide after absorption react in such a way that hydrogen cyanide is eventually released. Their effects on the body are essentially similar to those of hydrogen cyanide, but, in addition, they also have local irritant effects.

### **516. Physical and Chemical Properties.**

- a. Cyanogen chloride is a colorless, highly volatile liquid. Although only slightly soluble in water, it dissolves readily in organic solvents. Its vapour, heavier than air, is very irritating to the eyes and mucus membranes. Cyanogen chlorides pungent, biting odour is marked by its irritating lachrymatory properties. Normally cyanogen chloride is non persistent. (See Table 5-I.)
- b. Cyanogen halides are rather poorly absorbed onto charcoal, especially if the charcoal is damp. The cyanide group, not being ionised, does not react well with the metal salts found in respirator charcoals.

### **517. Detection.**

Automatic detectors are available which detect attack concentrations of vapour. Draeger™ tubes are also available, as are water testing kits.

### **518. Decontamination.**

See hydrogen cyanide.

*Table 5-I. Physical Properties of Cyanogen Agents*

Property	Hydrogen Cyanide (AC)	Cyanogen Chloride (CK)
Appearance	Colourless liquid giving off a colourless vapour	Strongly irritating colourless gas
Chemical formula	HCN	CNCl
Molecular weight	27.02	61.48
Density (g.cm <sup>-3</sup> )	0.687 (10°C)	1.18 (20°C)
Melting point	-13.3°C	-6.9°C
Boiling point	25.7°C	12.8°C
Vapour density	0.93	2.1
Vapour pressure	165 (-10°C) 256 (0°C) 600 (20°C) 742 (25°C)	1,010 (20°C)
Volatility (mg.m <sup>-3</sup> )	37,000 (-40°C) 1,080,000 (25°C)	6,132,000 (25°C)

### 519. Mechanism of Action.

Cyanogen chloride acts in two ways. Its systemic effects are similar to those of hydrogen cyanide but it also has local irritant effects on the eyes, upper respiratory tract and lungs.

### 520. Pathology.

Cyanogen chloride injures the respiratory tract, resulting in severe inflammatory changes in the bronchioles and congestion and oedema in the lungs. Very low concentrations (e.g., 10-20 mg.min.m<sup>-3</sup>) produce eye irritation and lachrymation.

### 521. Signs and Symptoms.

The signs and symptoms caused by cyanogen chloride are a combination of those produced by hydrogen cyanide and a lung irritant. Initially, cyanogen chloride stimulates the respiratory centre and then rapidly paralyses it. In high concentrations, however, its local irritant action may be so great that dyspnoea is produced. Exposure is followed by an immediate intense

irritation of the nose, throat and eyes, with coughing, tightness in the chest and lachrymation. Afterwards the exposed person may become dizzy and increasingly dyspnoeic. Unconsciousness is followed by failing respiration and death within a few minutes. Convulsions, retching and involuntary defecation may occur. If these effects are not fatal, the signs and symptoms of pulmonary oedema may develop. There may be persistent cough with much frothy sputum, rales in the chest, severe dyspnoea and marked cyanosis.

### **522. Treatment.**

Cyanogen halide poisoning should be treated in the same way as hydrogen cyanide poisoning as regards its cyanide-like effects. Pulmonary irritation should be treated in the same way as phosgene poisoning.

### **523. Course and Prognosis.**

Recovery from the systemic effects of cyanogen halide poisoning is usually as prompt as in hydrogen cyanide poisoning. However, a higher incidence of residual damage to the central nervous system is to be expected. Depending on the concentration of cyanogen halide to which the casualty has been exposed, the pulmonary effects may develop immediately or may be delayed until the systemic effects have subsided. Early prognosis must, therefore, be guarded.



## CHAPTER 6

## INCAPACITANTS

## SECTION I-GENERAL

**601. Introduction.**

- a. An incapacitant is a chemical agent which produces a temporary disabling condition that persists for hours to days after exposure to the agent has occurred (unlike that produced by riot control agents). Medical treatment while not essential may in some cases facilitate more rapid recovery. In the narrower sense the term has come to mean those agents that are:
  - (1) Highly potent (an extremely low dose is effective) and logistically feasible.
  - (2) Able to produce their effects by altering the higher regulatory activity of the central nervous system.
  - (3) Of a duration of action lasting hours or days, rather than of a momentary or fleeting action.
  - (4) Not seriously dangerous to life except at doses many times the effective dose.
  - (5) Not likely to produce permanent injury in concentrations which are militarily effective.
- b. These criteria eliminate many drugs that might otherwise be considered as incapacitants. Opiates and strong sedatives are too dangerous on account of their low margin of safety and milder tranquilizers cause little actual loss of performance capability. Many compounds have been considered as incapacitants and medical staffs must be on the alert to detect and report any unusual clinical appearances. All lethal agents in low doses may produce incapacitating effects and it is possible that new agents for incapacitation may be developed. Agents which produce unconsciousness or induce vomiting may well be developed in the future.
- c. In this chapter, consideration will be given to two categories which are well known: CNS depressants (anticholinergics) and CNS stimulants (LSD). Although cannabinols and psilocybin, for instance, have been considered in the past, their effective dose is too high for these to be regarded as likely agents for use in the field.

**602. CNS Depressants.**

CNS depressants produce their effects by interfering with transmission of information across central synapses. An example of this type of agent is 3-quinuclidinyl benzilate (BZ), which blocks the muscarinic action of acetylcholine both peripherally and centrally. In the central nervous system anticholinergic compounds disrupt the high integrative functions of memory, problem solving, attention and comprehension. Relatively high doses produce toxic delirium which destroys the ability to perform any military task.

### 603. CNS Stimulants.

CNS stimulants cause excessive nervous activity by facilitating transmission of impulses. The effect is to flood the cortex and other higher regulatory centres with too much information, making concentration difficult and causing indecisiveness and inability to act in a sustained purposeful manner. A well known drug which acts in this way is D-lysergic acid diethylamide; similar effects are sometimes produced by large doses of amphetamines.

### 604. Detection.

- a. Field laboratory methods are not yet sufficiently developed to permit isolation and identification of specific agents in the environment and in samples of body fluid (for example, blood, urine, cerebrospinal fluid). Therefore, diagnosis rests almost entirely upon chemical acumen, combined with whatever field intelligence or detector system data may be available. Following the occurrence of a suspected chemical attack with incapacitating agents, the medical officer should be prepared to take the steps listed below.
- b. Instruct field evacuation teams to transport casualties to an uncontaminated area. Resistant or disoriented individuals should be restrained in the triage area after they have been given the necessary first aid.
- c. Once the diagnosis of a nerve agent or other lethal substance has been ruled out, the principal signs and symptoms to consider are those shown in Table 6-I.
- d. In a large-scale attack, the diagnosis will be simplified by the epidemiological distribution of the casualties. It is better to look for characteristics common to all or most casualties, then to be overly impressed with atypical features. For example, some anticholinergics are capable of causing marked disorientation, incoherence, hallucinations and confusion (the pathognomonic features of delirium) with very little, if any, evidence of peripheral autonomic effect (such as tachycardia and dilated pupils). This should not dissuade the medical officer from considering the likelihood of a centrally predominant anticholinergic being the causative agent, since very few other pharmaceutical classes can produce delirium in militarily effective doses. The disturbance produced in indoles (such as LSD) or the cannabinoids (such as marijuana extracts) is not really delirium, because the casualties remain receptive to their environment and can comprehend quite well, even though they may have great difficulty reacting appropriately.

### 605. Protection.

It is likely that such agents will be dispersed by smoke-producing munitions or aerosols, using the respiratory tract as a portal of entry. The use of the protective mask, therefore, is essential. With some agents the percutaneous route may be used and full individual protective equipment will be required.

*Table 6-I. Signs and Symptoms Produced by Incapacitating Agents*

Signs and symptoms	Possible aetiology
Restlessness, dizziness, or giddiness; failure to obey orders, confusion, erratic behaviour; stumbling or staggering; vomiting.	Anticholinergics (e.g., BZ), indoles (e.g., LSD), cannabinoids (e.g., marijuana), anxiety reaction, other intoxications (e.g., alcohol, bromides, barbiturates, lead).
Dryness of mouth, tachycardia at rest, elevated temperature, flushing of face; blurred vision, pupillary dilation; slurred or nonsensical speech, hallucinatory behaviour, disrobing, mumbling and picking behaviour, stupor and coma.	Anticholinergics.
Inappropriate smiling or laughter, irrational fear, distractability, difficulty expressing self, perceptual distortions; labile increase in pupil size, heart rate, blood pressure. Stomach cramps and vomiting may occur.	Indoles. (Schizophrenic psychosis may mimic in some respects.)
Euphoric relaxed, unconcerned daydreaming attitude, easy laughter; hypotension and dizziness on sudden standing.	Cannabinols.
Tremor, clinging or pleading, crying; clear answers, decrease in disturbance with reassurance; history of nervousness or immaturity, phobias.	Anxiety reaction.

**606. Decontamination.**

Complete cleansing of the skin with soap and water should be accomplished at the earliest opportunity. Symptoms may appear as late as 36 hours after percutaneous exposure, even if the skin is washed within an hour. In fact, a delay in onset of several hours is typical. This time should be used to prepare for the possibility of an epidemic outbreak 6 to 24 hours after the attack.

**SECTION II - CNS DEPRESSANTS - BZ (3-QUINOCLINIDINYL BENZILATE) AND SIMILAR COMPOUNDS**

**607. Detection.**

There is no device available at present for detecting this agent.

**608. Protection.**

Protection is given by the respirator, NBC suit, overboots and gloves.

**609. Properties.**

- a. BZ and its analogues are glycollic acid esters. Some members of the group are liquid at ambient temperatures but BZ is a stable white crystalline powder that is only slightly soluble in water.
- b. These agents are metabolised primarily in the liver and excreted by the kidneys.

**610. Mechanism of Action.**

- a. BZ (3-quinuclidinyl benzilate) is a cholinergic blocking agent that at single doses of less than 1 mg produces delirium lasting several days. In this respect it resembles the well known belladonna alkaloids, atropine and scopolamine, except that it is more potent and its effects last longer. The safety margin (ratio of lethal to incapacitating dose) in people is estimated to be at least 30. No permanent adverse effects have been reported from clinical studies.
- b. BZ is effective by all routes of administration, but its effectiveness percutaneously (when mixed with a suitable solvent) is limited, so that route is not likely to be used. However there are other related compounds which are effective percutaneously.
- c. It readily crosses the blood-brain barrier and is distributed to all areas of the brain and spinal cord.
- d. After administration of an effective dose by inhalation by mouth or by injection mild peripheral effects of BZ occur within 1 hour and maximal central effects occur after about 4 hours lasting 24 to 48 hours, with a peak at 8 to 10 hours. Some other compounds in this group may take longer for their effects to develop and to disappear. Doubling the dose prolongs the duration of severe central effects by about 40 hours and shortens the onset time of severe effects to about 1 hour.
- e. BZ and other glycollates produce their effects within the nervous system in the same way as atropine and scopolamine, that is by interfering with cholinergic transmission at muscarinic sites, both in the peripheral autonomic nervous system and in the brain and spinal cord. Because of the wide distribution of these sites measurable effects upon almost every phase of neural regulation may be observed.

**611. Signs and Symptoms.**

Small doses of BZ cause sleepiness and diminished alertness. Diagnosis can be made by noting increased heart rate, dry skin and lips, drowsiness and a progressive intoxication in the untreated individual as follows:

- a. *1-4 hours:* Tachycardia, dizziness, ataxia, vomiting, dry mouth, blurred vision, confusion, sedation progressing to stupor.
- b. *4-12 hours:* Inability to respond to the environment effectively or to move about.

- c. *12-96 hours*: Increasing activity, random unpredictable behaviour with delusions and hallucination; gradual return to normal 48 to 96 hours after exposure.

### 612. Treatment.

- a. For most casualties, symptomatic treatment is all that will be necessary. Firm restraint when necessary and a friendly attitude are called for especially in dealing with these subjects who are capable of walking. All dangerous objects must be removed and anything likely to be swallowed should be kept away from the subject as bizarre delusions may occur.
- b. The most important single medical consideration is the possibility of heat stroke. Clothing should be removed if the temperature is greater than 25°C. If the body temperature is greater than 39°C vigorous cooling is indicated. The casualty should be placed in the shade and air allowed to circulate. Water may be sprayed on the casualty to aid cooling, ice should *not* be applied to the skin.
- c. Physostigmine, which is used as an antidote to BZ, should be reserved for casualties who appear to be in danger. Where this treatment is deemed to be necessary an injection of 2-3 mg will be required to alleviate the condition. Repeated injections at intervals of approximately 15 minutes to 1 hour may be required to build up a sufficient level. Once a desirable effect is achieved it should be maintained by slow intravenous injection or infusion. Doses of 2-4 mg every 1 or 2 hours may be required. The dose should be titrated against symptoms with gradual tapering of the dose as the effect of the poisoning runs its course. This may vary from a few hours to several days. Oral dosing should replace intravenous therapy as soon as possible (2 to 5 mg every 1 to 2 hours).
- d. Peripherally acting drugs, which do not cross the blood-brain barrier, such as pyridostigmine, neostigmine and pilocarpine are ineffective antagonists of the central effects of BZ and should not be used in place of physostigmine.

## SECTION III - CNS STIMULANTS-LSD (D-LYSERGIC ACID DIETHYLAMIDE)

### 613. Properties.

LSD is solid at normal temperatures and is soluble in water. It is a very difficult agent to disseminate and consequently is likely to be used by an enemy only in a clandestine manner.

### 614. Detection.

There is no device available for detecting this agent in the field.

### 615. Protection.

No personal protection is available against clandestine attack, but it seems probable that only small quantities of food or water could be contaminated. Good security of the food and water supply are therefore required.

**616. Mechanism of Action.**

- a. Very small doses (for example 50 micrograms per person) are capable of inducing a psychotic state in people, but the precise mechanism of action is not yet known.
- b. LSD has been shown to facilitate neural activity in the reticular activating system of the brain stem. It appears to interfere with the normal filtering action of this system, permitting sensory input to reach higher integrative centres without regard to its importance or relevance. The result is a decrease in the ability of the brain to process information selectively and in logical sequence.

**617. Pathophysiology.**

- a. D-lysergic acid diethylamide is the most potent of the biologically active indole compounds, as little as 50 µg being required to produce dramatic psychological changes. Doses of 2 to 5 mg have been taken without permanent sequelae, and animal studies suggest that much higher doses may be tolerated. Convulsions may occur at doses above 2 mg.
- b. LSD may be inhaled or ingested. Initial effects appear within a few minutes of inhalation or within 30 to 60 minutes of ingestion. Maximum effects are reached within 2 to 3 hours and gradually subside over the next 4 to 8 hours. The half-life in human plasma is about 3 hours. Tolerance is acquired rapidly on repeated exposures at daily intervals, but is shortlived.
- c. LSD appears to interact with endogenous neurotransmitters such as serotonin with which it shares the common feature of an indole nucleus. It is metabolised by the liver and excreted through the kidneys.

**618. Signs and Symptoms.**

- a. The clinical manifestations of LSD intoxication often include an early stage of nausea followed 45-60 minutes after dosage by a confused state in which delusions and hallucinations are common but not always experienced. There is some evidence that the effects may be held off, at least for a time, by determination to continue duty and that the presence of non-intoxicated comrades enables affected subjects to maintain contact with reality.
- b. Subjects intoxicated with LSD show evidence of sympathetic stimulation (rapid heart rate, sweating palms, pupillary enlargement, cold extremities) and mental excitation (nervousness, trembling or spasms, anxiety, euphoria and inability to relax or sleep). Hyperthermia has been reported. Subjectively, feelings of tension, heightened awareness, exhilaration, kaleidoscopic imagery, emotions of every type, hilarity and exultation are characteristic. Paranoid ideas and more profound states of terror and ecstasy may also occur, especially in highly suggestible individuals. True hallucinations are rare, as is homicidal or suicidal behaviour.

**619. Treatment.**

No true antagonist to the indoles is as yet known. The best treatment known at present for LSD intoxication is the administration of diazepam 10-20 mg intravenously or intramuscularly or sodium amytal 200-400 mg intravenously to sedate the patient until spontaneous recovery occurs. Chlorpromazine has also been suggested but does not appear to have any advantage over these drugs.

**620. Course and Prognosis.**

The question of long term effects is still unresolved, but single exposures to doses in the clinical range (0.1 to 1.0 mg total dose) appear unlikely to cause any permanent biological damage.

**621. Other Agents.**

Unfamiliar agents or mixtures of agents may be encountered in future battlefield situations. In such instances, the general principles of restraint, close observation and supportive medical care apply. No medication should be given until an aetiological diagnosis can be made with reasonable certainty unless circumstances require it (for example, concomitant wounds, burns or fractures requiring major surgical intervention). The judgement of the medical officer remains the only useful guide to action in these complex and unforeseeable circumstances.

## CHAPTER 7

## RIOT CONTROL AGENTS

## SECTION I - GENERAL

**701. Introduction.**

Riot control agents are irritants characterised by a very low toxicity (chronic or acute) and a short duration of action. Little or no latent period occurs after exposure. Orthochlorobenzylidene malononitrile (CS) is the most commonly used irritant for riot control purposes. Chloracetophenone (CN) is also used in some countries for this purpose in spite of its higher toxicity. A newer agent is dibenzoxazepine (CR) with which there is little experience. Arsenical smokes (sternutators) have in the past been used on the battlefield. Apart from their lachrymatory action they also provoke other effects, e.g., bronchoconstriction and emesis and are some times referred to as vomiting agents. For historical reasons some older, more toxic compounds are briefly mentioned.

## SECTION II - LACHRYMATORS

**702. CS (Orthochlorobenzylidene Malononitrile).**

CS is used as a riot control agent in many countries. It is also commonly used as a training agent for simulation of chemical warfare conditions and for testing of respirators. The limit of perception by taste ranges from 0.25-0.5 mg.m<sup>-3</sup>. The minimal irritant concentration ranges from 0.1- 1.0 mg.m<sup>-3</sup>, the IC<sub>t50</sub> from 5-10 mg.m<sup>-3</sup>, and the LC<sub>t50</sub> for persons very much larger, estimated as 60,000 mg.min.m<sup>-3</sup>. This provides a high margin of safety in its use.

**703. Properties.**

CS is the code name for orthochlorobenzylidene malononitrile. On account of its stronger irritant effects and its lower toxicity it has superseded CN. It is a white crystalline solid substance. Volubility is very poor in water, moderate in alcohol and good in acetone, chloroform, methylene dichloride, ethylacetate and benzene. CS is unstable in aqueous solution. If enough CS can be dissolved in water (e.g., by adding propylene glycol or other organic co-solvent) spraying fluids with an irritant action of short duration result. Although the smoke is non-persistent, CS may stick to rough surfaces (e.g., clothes) from which it is released only slowly. At least 1 hour of aeration is necessary to cleanse such materials from CS after exposure. CS is usually dispersed as an aerosol generated pyrotechnically, or by spraying a solution of CS in a suitable solvent.

**704. Detection.**

The CS cloud is white at the point of release and for several seconds after release. Exposure is associated with a pepper-like odour, the presence of intense eye effects, dyspnoea, coughing and rhinorrhoea.



**705. Protection.**

Full individual protective equipment will provide complete protection. Protection against field concentrations of irritant agents is provided by the respirator and ordinary field clothing secured at the neck, wrists and ankles. Individuals who handle CS should wear rubber gloves, hood, rubber boots, rubber apron and respirator and secure their field clothing at the neck, wrists and ankles.

**706. Decontamination.**

- a. Exposed persons should if possible move to fresh air, separate from fellow sufferers, face into the wind with eyes open and breathe deeply.
- b. Following exposure, clothing and individual equipment should be inspected for residue. If a residue is found, individuals should change and wash their clothing to protect themselves and other unmasked persons.

**707. Mechanism of Action.**

- a. Lachrymators act on the nerve endings, the cornea, mucous membranes and the skin. The reaction is very rapid.
- b. The toxicity of CS is very low, the estimated lethal concentration over 1 hour for people being  $1000 \text{ mg.m}^{-3}$ , whereas a concentration of  $1 \text{ mg.m}^{-3}$  is intolerable to most people.

**708. Pathology.**

Pathological examination of rabbits exposed to CS revealed an increase in number of goblet cells in the respiratory tract. Pulmonary oedema occurred after inhalation at very high concentrations, in excess of  $20000 \text{ mg.min.m}^{-3}$ . Experiments in dogs showed that the animals dying as a result of exposure to very high concentrations died from obstruction of the upper respiratory tract; inhalation of CS through an intratracheal cannula, on the other hand, caused pulmonary oedema.

**709. Signs and Symptoms.**

During exposure an individual is incapable of effective concerted action.

**710. CS Exposure Symptoms.**

Exposure to CS causes the following symptoms:

- a. *Eyes.* Symptoms include a violent burning sensation, conjunctivitis (lasting up to 30 minutes), erythema of the eyelids (lasting about an hour) blepharospasm, violent lachrymation (over 10-15 minutes) and photophobia.
- b. *Respiratory Tract.* The first symptom is a burning sensation in the throat, developing into pain and extending to the trachea and bronchi. At a later stage a sensation of

suffocation may occur, often accompanied by fear. In addition a burning sensation in the nose, rhinorrhoea, erythema of the nasal mucous membranes and sometimes mild epistaxis occurs. The sense of taste is often distorted for some hours after exposure. Nausea, diarrhoea and headache have been observed. Sneezing occurs after mild exposure and may be persistent. Many exposed people have reported fatigue for some hours afterwards. Coughing, choking, retching and (rarely) vomiting occur after exposure.

- c. *Skin*. A burning sensation occurs especially in moist areas, but soon disappears. This burning sensation may recur some hours later, often while washing the area. Prolonged exposure to large amounts (e.g., when handling CS in bulk) can cause erythema and vesicle formation. Prolonged exposure, continuous or intermittent, to high concentrations, combined with high temperatures and humidity in the field may result in a cumulative effect. Sensitivity to CS may be provoked. It has been shown that the particle size affects the clinical result. Small particles (1-5  $\mu\text{m}$ ) affect the eyes and respiratory tract more rapidly than larger ones (20-30  $\mu\text{m}$ ) but recovery after exposure to small particles is more rapid. Very large particles (50  $\mu\text{m}$ ) affect the eyes more than the respiratory tract, while recovery is slower.

### 711. First Aid.

- a. In practically all cases it is sufficient to take the patient into fresh air where the symptoms will soon disappear. Clothing should be changed. If symptoms persist the eyes, mouth and skin may be washed with water (and with soap in the case of the skin). Oil based lotions should *not* be used. Skin decontaminants containing bleach should *not* be used, but should be reserved for more dangerous contamination (e.g., vesicants or nerve agents); bleach reacts with CS to form a combination which is more irritant to the skin than CS alone. Chest discomfort can usually be relieved by reassurance.
- b. CS hydrolyses more rapidly in alkaline solutions and an acceptable skin decontamination solution is 6.7% sodium bicarbonate, 3.3% sodium carbonate and 0.1% benzalkonium chloride.

### 712. Therapy.

- a. *Eyes*. Ordinarily the eye effects are self limiting and require no treatment. If large particles or droplets of agent have entered the eye, treatment as for corrosive materials may be required. Prompt irrigation with copious amounts of water is the best treatment for solid CS in the eye. After complete decontamination corticosteroid eye preparations may be used. Patients who have been heavily exposed must be observed for possible development of corneal opacity and iritis.
- b. *Skin*. Early erythema and stinging sensation (up to 1 hour), especially in warm moist skin areas, are usually transient and require no treatment. Inflammation and blistering similar to sunburn may occur after heavy or prolonged exposure, especially in fair skin. Acute contact dermatitis should be managed initially in the same way as any other acute dermatitis. Corticosteroid cream or calamine lotion

may be applied to treat existing dermatitis or to limit delayed erythema. Oozing may be treated with wet dressings of 1 in 40 aluminium acetate solution for 30 minutes three times daily. A topical steroid should follow the wet dressing immediately. Secondary infection is treated with appropriate antibiotics. Significant pruritus can be treated with calamine lotion or corticosteroid preparations. If blisters develop these should be treated as any other second degree burn.

- c. *Respiratory Tract.* In the rare event of pulmonary effects from massive exposure, evacuation is required. Management is the same as that for lung damaging agents (Chapter 4).

### 713. Course and Prognosis.

Most personnel affected by riot control agents require no medical attention and casualties are rare.

### 714. CR (Dibenzoxazepine).

- a. CR is similar in its effects to CS, but the minimum effective concentration is lower and the  $LCt_{50}$  is higher. Symptomatology and treatment are similar to those of CS.
- b. It is a pale yellow crystalline solid which melts at 163°F (73°C) and is stable in organic solutions. It has limited volatility in water and is not hydrolysed in aqueous solutions. It has a pepper-like odour. The agent is currently used only in solution for dissemination in liquid dispensers. The solution in the dispensers contains 0.1% CR in 80 parts propylene glycol and 20 parts water. In organic solutions, CR is an eye irritant at concentrations down to 0.0025% or even lower. CR differs from CS in being less toxic when inhaled but CR skin effects are more pronounced. It is more persistent in the environment and on clothing.

### 715. CN (Chloracetophenone).

CN is a riot control agent and as a training agent is now superseded by CS, the latter being much less toxic. However, it is still in use by police in some countries.

### 716. Properties.

CN is a clear yellowish brown solid, with a melting point of 54 °C. It is poorly soluble in water, but dissolves in organic solvents. The white smoke smells like apple blossom. The minimal irritant concentration is 0.3 mg.m<sup>-3</sup>. It has been estimated from experimental data that the  $LCt_{50}$  for people is 7000 to 14000 mg.min.m<sup>-3</sup>, but inhalation of 350 mg.m<sup>-3</sup> for 5 minutes may be dangerous. The  $ICt_{50}$  is 20 to 40 mg.min.m<sup>-3</sup>. CN is more toxic than CS.

### 717. Mode of Action and Toxic Effects.

The mode of action is similar to that of CS; CN causes stimulation of sensory nerve endings.

**718. Signs and Symptoms.**

Exposure to CN primarily affects the eyes, producing a burning sensation, lachrymation, inflammation and oedema of the eyelids, blepharospasm, photophobia and, at high concentrations, temporary blindness. The severest of these symptoms is reached in a few minutes and then gradually decreases. After about 1 or 2 hours all symptoms disappear. High concentrations can cause irritation of the upper respiratory tract, inflammation of the skin with vesicle formation, visual impairment and pulmonary oedema. Drops or splashes in the eye may cause corrosive burns, corneal opacity and even permanent visual impairment. Drops or splashes on the skin may cause papulovesicular dermatitis and superficial skin burns. Ingestion of food or water contaminated with CN causes nausea, vomiting and diarrhoea.

**719. First Aid.**

After limited operational exposure ill effects will be adequately neutralised by letting fresh air blow into the open eyes. If necessary the eyes maybe washed with water from the water bottle (canteen). The eyes should never be rubbed as mechanical injury may complicate the chemical effect. Patients suffering from temporary blindness should be reassured; permanent blindness from exposure to *vapour* has never been observed even at very high concentrations.

**720. CA (Bromobenzyl Cyanide) and BA (Bromoacetone).**

Bromobenzyl cyanide (CA) and bromoacetone (BA) are older lachrymators. They are too toxic for use as riot control agents and must be considered obsolete. Their properties are listed in Table 7-I.

*Table 7-I. Properties of CA and BA*

Property	CA	BA
Appearance	Yellow, solid	Colourless liquid
Melting point	25°C	-54°C
Boiling point	227-242°C	136°C
Specific gravity	1.52	1.63
Solubility in water	Poor	Poor
Solubility in organic solvents	Good	Good
Volatility (mg.m <sup>-3</sup> )	130 (30°C)	75000 (30°C)
Smoke vapour odour	Rotting fruit	Stinging
Smoke vapour colour	White	Colourless
Minimal irritant concentration	0.3 mg.m <sup>-3</sup>	1.0 mg.m <sup>-3</sup>

## SECTION III - VOMITING AGENTS

**721. Introduction.**

Vomiting agents produce strong pepper-like irritation in the upper respiratory tract with irritation of the eyes and lachrymation. They cause violent uncontrollable sneezing, cough, nausea, vomiting and a general feeling of bodily discomfort. The principal agents in this group are diphenylchlorarsine (DA), diphenylaminearsine chloride (Adamsite (DM)) and diphenylcyanarsine (DC). DA, DM, and DC are also classed as sternutators. They are dispersed as aerosols and produce their effects by inhalation or by direct action on the eyes.

**722. Properties.**

- a. *Characteristics.* They are non-persistent agents. The particles fall to the ground after dispersion and are virtually ineffective unless resuspended. Di-phenyl-cyanoarsine (DC) is the most irritating of the group. The principal characteristics of these agents are summarised in Table 7-II.
- b. *Visual Detection.* It should be remembered that the colour of the solid agent depends on the degree of purity (technically raw products are often coloured) but the colour and odour of the smoke after dispersion may no longer be noticeable in concentrations which are nevertheless still highly irritant, so that odour and colour cannot be relied upon for detection.
- c. *Toxicity.* The following data are applicable to DM. The  $LCt_{50}$  estimated for people is 13000 to 44000  $mg \cdot min \cdot m^{-3}$  depending on the means of dissemination of the agent. The  $ICt_{50}$  for man ranges from 22 to 150  $mg \cdot min \cdot m^{-3}$ . The maximum concentration which is stated to cause no permanent damage after inhalation for 5 minutes is 100  $mg \cdot m^{-3}$ .

*Table 7-II. Properties of Vomiting Agents*

Property	DM	DA	DC
Appearance	Yellow or green solid	Colourless, crystalline	Colourless, solid
Melting point	195°C	38°C	38°C
Boiling point	410°C	330°C	346-337°C
Specific gravity	1.68	1.4	
Solubility in water	Poor	Poor	Poor
Solubility in organic solvents	Poor	Good	Good
Volatility ( $mg \cdot m^{-3}$ )	0.02 (20°C)	0.68 (20°C)	1.5 (20°C)
Smoke vapour odour	Coal fire	Shoe polish	Garlic
Smoke vapour colour	Yellow	White or grey	White
Minimal irritant concentration	0.1 $mg \cdot m^{-3}$	0.1 $mg \cdot m^{-3}$	0.25 $mg \cdot m^{-3}$

**723. Detection.**

The use of these agents may be suspected by the clinical symptoms and signs.

**724. Protection.**

Full individual protective equipment will provide complete protection. The standard protective respirator and ordinary field clothing gives adequate protection against field concentrations of vomiting agents.

**725. Mechanism of Action.**

This consists of inhibition of the SH containing enzymes, especially those of the pyruvate dehydrogenase system. These enzymes play a part in the energy producing processes in the cell. The integrity of the cell structure depends on the proper functioning of the metabolic processes and inhibition of the enzyme mentioned interferes with cell respiration resulting in the destruction of cell structure.

**726. Pathology.**

Vomiting agents produce local inflammation of the upper respiratory tract, the nasal accessory sinuses and the eyes.

**727. Signs and Symptoms.**

- a. The onset of symptoms may be delayed for several minutes after initial exposure (especially with DM); effective exposure may, therefore, occur before the presence of the smoke is suspected. If the mask is put on then, symptoms will increase for several minutes despite adequate protection. As a consequence, the casualties may believe their mask is ineffective and by removing it expose themselves further.
- b. Inhalation is followed by a burning sensation in the nose and throat, hypersalivation, rhinorrhea, coughing, sneezing, nausea and vomiting. Mental depression may occur during the progression of symptoms. The paranasal sinuses are irritated and fill with secretions and severe frontal headache results. Prolonged exposure may cause retrosternal pain, dyspnoea and asthma-like symptoms. Symptoms reach their climax after 5 to 10 minutes and disappear 1 to 2 hours after cessation of exposure. Effects on the eyes are slight and are restricted to a burning sensation and lachrymation. Exposure of the skin to high concentrations will cause erythema and itching, proceeding to a burning sensation and vesicle formation. On the battlefield, high concentrations are not likely to occur so that affection of the eyes and skin is unlikely. Ingestion of food and water contaminated by sternutators may cause nausea, vomiting, diarrhoea (sometimes bloodstained) and weakness and dizziness have been reported.

- c. High concentrations are not expected in the open owing to movement of air, but may be met within enclosed spaces (shelters, tents, etc.), and under these circumstances the skin may show vesicle formation, capillary damage and localised swelling, while corneal necrosis and pulmonary oedema are possible results. Unsteady gait and a positive Romberg sign have been reported. Other neurological results of severe exposure include hyperaesthesia, anesthesia and paraesthesiae, especially in the legs. Loss of consciousness has been reported.

#### **728. Treatment.**

- a. Put on the protective mask and wear it in spite of coughing, sneezing, salivation and nausea. Lift the mask from the face briefly if necessary to permit vomiting or to drain saliva from the facepiece. Carry on with duties as vigorously as possible - this will help to lessen and shorten the symptoms. Combat duties usually can be performed despite the effects of vomiting agents.
- b. In spite of the dramatic appearance of the syndrome, the only treatment necessary is first aid. The patient should not smoke for some hours. If necessary the mouth may be rinsed with water, but the water should not be swallowed. The eyes and skin may be washed with water. Clothing should be well brushed. In cases of severe exposure treatment as for lung damaging agent poisoning may be required. A mild analgesic may be given to relieve headache and general discomfort.

#### **729. Course and Prognosis.**

Symptoms of exposure to field concentration of vomiting agents usually disappear in 20 minutes to 2 hours, leaving no residual injury. However, a few instances of severe pulmonary injury and death have occurred due to accidental exposure to high concentrations in confined spaces.

## CHAPTER 8

## SMOKES, FUELS, AND INCENDIARY MATERIALS

## SECTION I - SMOKES

**801. Introduction.**

- a. Smokes are used to hide troops, equipment and areas from detection by obscuring vision. The smokes consist of small solid or liquid particles which become hydrated in contact with air and intercept or diffuse the light.
- b. Most smokes are not hazardous in concentrations which are useful for obscuring purposes. However, exposure to heavy smoke concentrations for extended periods, particularly if near the source of emission, may cause illness or even death. Medical personnel should, therefore, be prepared to treat potential reactions to military smokes once such smokes have been introduced to the battlefield. Except with oil smoke, high concentrations of smoke generated in closed spaces are extremely dangerous. High concentrations of zinc chloride smoke generated under these conditions have caused fatalities. Under no circumstances should zinc chloride munitions be used indoors or in closed compartments.
- c. In the open air, the air passages should be protected by a respirator if the smoke irritates the airway, if it is very thick or if a stay of longer than 5 minutes in a diluted cloud is necessary. The standard respirator gives the respiratory tract and eyes adequate protection against all smokes and should always be worn when smokes are used in confined spaces. It will not, however, protect against carbon monoxide.

**802. Zinc Chloride Smokes.**

Several methods of producing smoke by dispersing fine particles of zinc chloride have been developed. The mixture in common use is zinc chloride smoke mixture (HC), which contains hexachloroethane, grained aluminium and zinc oxide. Upon burning, the mixture produces zinc chloride, zinc oxychlorides and HCl vapour which rapidly absorb moisture from the air to form a greyish white smoke. HC mixtures can be dispersed by several methods, including grenades, candles, smoke pots, cartridges, and air bombs.

**803. Protection.**

Some countries require the use of a respirator to protect the respiratory tract whenever zinc chloride smokes are used.

**804. Clinical-Pathological Effects.**

- a. *Toxicity.* The toxicity of zinc chloride is mainly due to the formation of the strongly acidic HCl, but is also to a lesser extent due to thermal lesions. These are caused by



the exothermic reaction of zinc chloride with water. The acidic HCl vapour causes lesions of the mucous membranes of the upper airways. The damage and clinical symptoms following zinc chloride exposure therefore appear immediately after the start of the exposure. However, damage to the lower airways also occurs and may result in delayed effects. These have been attributed to the presence of fine zinc chloride particles and phosgene.

- b. *Acute Effects.* In high concentrations or with prolonged exposure HC smoke is highly irritating and may be very dangerous when inhaled. Symptoms following inhalation of high concentration of zinc chloride smoke include dyspnoea, retrosternal pain, hoarseness, stridor, lachrymation, cough, expectoration and occasionally haemoptysis. Cyanosis and bronchopneumonia may develop. Due to the irritant and astringent nature of the compound, delayed pulmonary oedema may occur even in the presence of distinct and short-lasting initial symptoms. It is caustic to mucous membranes and can also cause subacute interstitial fibrosis.
- c. *Chronic Effects.* Recent studies of the HC canister and of HC smoke reaction by-product gases indicate the presence of suspected carcinogens. Metal analysis of HC canisters showed, besides zinc, small amounts of cadmium and trace amounts of lead, arsenic and mercury. The by-product gases include chlorinated compounds, phosgene, HCl, carbon monoxide and chlorine. Although zinc chloride, the main constituent, is not felt to be a carcinogenic hazard, certain of the other by-products are known carcinogens in laboratory animals or in humans.

### **805. Treatment.**

The casualty should don his or her respirator or be removed from the source of exposure. Oxygen should be administered in cases of hypoxia. Bronchospasm should be treated appropriately as should secondary bacterial infection. Early steroid therapy has been considered efficacious by some and, when used, steroids should be given in high doses similar to those used in the treatment of phosgene exposure and exposure to other lung damaging agents. Adequate analgesia is recommended.

### **806. Prognosis.**

The prognosis is related entirely to the extent of the pulmonary damage. All exposed individuals should be kept under observation for 8 hours. Most individuals recover in a few days. At moderate exposures, some symptoms may persist for 1 to 2 weeks. In severe exposures, survivors may have reduced pulmonary function for some months after exposure. The severely exposed patient may progressively develop marked dyspnoea, cyanosis and die.

### **807. Chlorosulphonic Acid (CSA).**

- a. Chlorosulphonic acid (CSA) is a heavy, strongly acidic liquid which, when dispersed in air, absorbs moisture to form a dense white fog consisting of small droplets of hydrochloric and sulphuric acids. In moderate concentrations it is highly irritating to the eyes, nose and skin. The respirator should be worn in all concentrations which

are sufficient to cause any cough, irritation of the eyes or prickling of the skin.

- b. A risk exists when chlorosulphonic acid comes in contact with water due to the generation of intense heat and the scattering of acid in all directions. Owing to its highly corrosive nature careful handling is required.

### **808. Symptoms.**

The symptoms are usually limited to a prickling sensation of the skin, but exposure to high concentrations or long exposures to lower concentrations as found in the field, may result in severe irritation of the eyes, skin and respiratory tract. Conjunctival irritation and oedema, lachrymation and mild photophobia may occur. Mild cough and soreness in the chest and moderate chemical dermatitis of the exposed skin are occasionally seen. Splashes of liquid in the eye are extremely painful and cause mineral acid burns with corneal erosions. Liquid chlorosulphonic acid solution on the skin may cause painful acid burns.

### **809. Treatment.**

- a. *Eye.* Irrigate the contaminated eye with water or saline as soon as possible. Examine the cornea for erosion by staining it with fluorescein. If corneal erosion is present, the casualty should be transferred to the care of an ophthalmologist. If this is not practicable, mydriasis should be induced by the use of atropine sulphate eye drops or ointment. Conjunctival lesions should heal readily, but corneal erosions may lead to residual scarring.
- b. *Skin.* Irritated skin or skin burns should be washed with water and then with sodium bicarbonate solution. The burns are then treated as for thermal burns of like severity.

### **810. Prognosis.**

The skin burns, conjunctival lesions and respiratory irritation heal readily. Corneal erosions are more serious and may lead to residual scarring.

### **811. Titanium Tetrachloride (FM).**

This is a yellow non-inflammable and corrosive fluid which on contact with damp air gives off a heavy dense white cloud. It is disseminated by aircraft for the production of vertical smoke curtains extending down to ground and sea level. The smoke consists of fine particles of free hydrochloric acid and titanium oxychloride. The smoke is unpleasant to breathe. Goggles or a respirator should be worn when the spray is falling due to the risk of droplets entering the eyes. Full protective clothing should be worn when handling the liquid to avoid contamination of eyes and skin.

### **812. Mode of Action.**

Liquid FM produces acid burns of the skin or eyes.

## SECTION II - FLAME MATERIALS

**813. General.**

- a. Incendiary agents are used to burn supplies, equipment and structures. The main agents in this group are thermite (TH), magnesium, white phosphorus (WP) and combustible hydrocarbons (including oils and thickened gasoline).
- b. Chemical fire extinguishers containing carbon dioxide should not be used in confined spaces to extinguish thermite or magnesium types of incendiaries. When carbon tetrachloride is in contact with flame or hot metal, it produces a mixture of phosgene, chlorine, carbon monoxide and hydrochloric acid. The standard respirator with normal canister does not protect against some agents such as carbon monoxide.

**814. Red and White Phosphorus.**

- a. At ordinary temperatures, white phosphorus (WP) is a solid which can be handled safely under water. When dry, it burns fiercely in air, producing a dense white smoke. Fragments of melted particles of the burning substance may become embedded in the skin of persons close to a bursting projectile, producing burns which are multiple, deep and variable in size. The fragments continue to burn unless oxygen is excluded by flooding or smothering.
- b. WP may be used to produce a hot dense white smoke composed of particles of phosphorus pentoxide which are converted by moist air to droplets of phosphoric acid. The smoke irritates the eyes and nose in moderate concentrations. Field concentrations of the smoke are usually harmless although they may cause temporary irritation to the eyes, nose or throat. The respirator provides adequate protection against white phosphorus smoke.
- c. In an artillery projectile white phosphorus is contained in felt wedges which ignite immediately upon exposure to air and fall to the ground. Up to 15% of the white phosphorus remains within the charred wedge and can re-ignite if the felt is crushed and the unburned white phosphorus exposed to the atmosphere.
- d. Red phosphorus (RP) is not nearly as reactive as white phosphorus. It reacts slowly with atmospheric moisture and the smoke does not produce thermal injury, hence the smoke is less toxic.

**815. Self Aid.**

- a. If burning particles of phosphorus strike and stick to the clothing, contaminated clothing should be removed quickly before the phosphorus burns through to the skin.
- b. If burning phosphorus strikes the skin, smother the flame with water, a wet cloth, or mud. Keep the phosphorus covered with the wet material to exclude air until the phosphorus particles can be removed.
- c. Try to remove the phosphorus particles with a knife, bayonet, stick or other available object. It may be possible to remove some particles by rubbing with a wet cloth.

**816. Medical Aid.**

- a. At the earliest opportunity all phosphorus should be removed from the skin and placed in a container so as to prevent further contamination and secondary injuries. The affected part should be bathed in a bicarbonate solution to neutralise phosphoric acid, which then allows removal of visible phosphorus. Remaining fragments will be observed in dark surroundings as luminescent spots.
- b. Some nations recommend washing the skin with a 0.5-2.0% copper sulphate solution or a copper sulphate impregnated pad. Wounds may be rinsed with a 0.1%-0.2% copper sulphate solution, if available. Dark coloured deposits may be removed with forceps. Prevent prolonged contact of any copper sulphate preparations with the tissues by prompt, copious flushing with water or saline, as there is a definite danger of copper poisoning. It may be necessary to repeat the first aid measures to completely remove all phosphorus.
- c. The burn should be debrided promptly, if the patient's condition will permit, to remove bits of phosphorus which might be absorbed later and possibly produce systemic poisoning. An ointment with an oily base should not be applied until it is certain that all phosphorus has been removed. Further treatment should be carried out as for thermal burn.
- d. If the eyes are affected, treatment should initially be commenced by irrigation with a 1% solution of copper sulphate or sodium bicarbonate 5%, followed by repeated lavage using water or saline. The lids must be separated and a local anesthetic instilled to aid in the removal of all embedded particles. In eyes with severe ulceration once all particles have been removed, atropine should be instilled. The patient should be transferred to the care of an ophthalmologist as soon as possible.

**817. Thermite.**

Thermite incendiaries are a mixture of powdered aluminium metal and ferric oxide and are used in bombs for attacks on armoured fighting vehicles. Thermite burns at about 2000°C and scatters molten metal, which may lodge in the skin producing small multiple deep burns.

**818. Treatment.**

The wound should be cooled immediately with water and the particles removed. Afterwards the treatment is that used for other thermal burns.

**819. Magnesium.**

Magnesium (Mg) burns at about 2000°C with a scattering effect similar to that of thermite. Its particles produce deep burns. Healing is slow unless these particles are removed quickly. Removal is usually possible under local anesthesia. When explosive charges have been added to a magnesium bomb, the fragments may be embedded deep in the tissues, causing the localised formation of hydrogen gas and tissue necrosis.

### SECTION III - HYDROCARBON FUMES

#### 820. General.

- a. Fuels consist largely of hydrocarbons which may have a narcotic effect. In this respect, because of their lower volatility, diesel and paraffin (kerosene) fuels are less dangerous than petrol (gasoline).
- b. Fumes from the combustion of these fuels in internal combustion or jet engines contain a proportion of carbon monoxide, nitrous fumes, etc., which varies with the characteristics of the engine and the rate at which it is being run. The overheating of lubricant oils may result in the production of acrolein which is an aldehyde with intense irritant properties. A concentration of  $5 \text{ mg.m}^3$  is immediately detectable by odour but a concentration of  $50 \text{ mg.m}^3$  causes death in a short time from pulmonary oedema.

#### 821. Physical and Chemical Properties.

Petrol, diesel and paraffin vapours are heavier than air and as a result of this may be encountered in fuel tanks, in vehicles or in spaces where fuels have been stored. As far as their chemical properties are concerned, the hydrocarbons are inert, except when in an oxidising atmosphere, which is capable of supporting combustion.

#### 822. Protection.

Although respirators provide full protection against these hydrocarbon fumes, there is a significant hazard from combustion products in confined spaces due to the presence of asphyxiant gases, e.g., carbon monoxide. In this case, self contained breathing apparatus is required.

#### 823. Mechanism of Action.

Hydrocarbon fumes are preferentially absorbed into lipid rich tissue, for instance, the central nervous system. Their action is narcotic and they produce unconsciousness and death in concentrations over 1% (10,000 ppm) in the case of petrol fumes. The exact dangerous concentrations depend on the volatility of the hydrocarbons in question, and on their aromatic content. Swallowed fuels produce unconsciousness, and permanent brain damage has been reported. Aspiration pneumonia may follow as a complication.

#### 824. Signs and Symptoms.

- a. Drowsiness and unconsciousness proceeding to death are encountered in severe poisoning. Less severe exposures may cause dizziness, headache, nausea, vomiting and muscular incoordination. Acute emotional disturbances following hydrocarbon poisoning have been reported.
- b. Lead poisoning from tetraethyl lead additives is very rare except among those who manufacture blended fuels. The risk of leucopenia has also been reported, in particular from workers using the aromatic hydrocarbon benzene.

**825. Treatment.**

Removal to fresh air is the only treatment necessary in cases of mild exposure. When severe poisoning has occurred, oxygen should be administered and positive pressure ventilation may be required.

**SECTION IV - INCENDIARY DEVICES - COMBUSTIBLE HYDROCARBON  
INCENDIARIES****826. Introduction.**

Burns may be produced by flame-throwers, oil incendiary bombs which may also contain phosphorus and sodium, and fire bombs containing thickened gasoline. Lung damage from heat and irritating gases may be a complication added to the injuries from incendiaries, especially in confined spaces.

**827. Flame-Thrower Attack.**

As flame and burning fuel fills an enclosed fortification, the oxygen content of the air is reduced and a hot toxic atmosphere containing large amounts of carbon monoxide, unburned hydrocarbons and smoke is produced. The coolest and least contaminated air is found at floor level.

**828. Casualties.**

Deaths may occur during or shortly after a flame attack due to the heat, the toxic atmosphere or suffocation caused by laryngeal or glottic oedema. Survivors may have thermal burns of the skin and upper respiratory tract, as well as pulmonary damage from the hot gases.

**829. Protection.**

The floor level is the safest area during a flame attack. Any kind of cover affords some protection from heat. A wool blanket is excellent. The mask may give partial protection against smoke.

**830. Treatment.**

Casualties should be removed to fresh air as soon as possible. Assisted ventilation (using oxygen, if available) should be administered if breathing has ceased. Burns of the skin are treated as thermal burns. If there are burns about the face, laryngeal burning with subsequent oedema-producing respiratory obstruction may occur, so that intubation, tracheotomy or cricothyroid cannulation can be performed in an emergency. The general treatment of the casualty produced by flame attack does not differ from the treatment of one with extensive thermal burns.

**831. Fire-Bomb Attack.**

A fire-bomb is a large tank containing thickened (gelled) gasoline that is air dropped. When it strikes the ground, the fuel is ignited by phosphorus igniters and a large fireball of intense heat is produced, lasting about 4 to 6 seconds. Also, a wide area of ground is covered with burning thickened gasoline, which may continue to burn for as long as 10 to 12 minutes.

**832. Casualties.**

Deaths may be caused by the intense heat or by suffocation from oedema of the larynx or glottis. Thermal burns of the skin and upper respiratory tract may occur in the survivors. Danger from a toxic atmosphere is small in fire-bomb attacks in an open or in a well-ventilated enclosure.

**833. Treatment.**

Burning clothing should be removed or the flames smothered. In general, treatment is similar to that used after flame-thrower attacks.

CHAPTER 9

HERBICIDES

SECTION I - GENERAL

901. Introduction.

- a. A herbicide is any preparation used to kill or inhibit the growth of plants. The term includes defoliants, desiccants, plant growth regulators and soil sterilants. Militarily, herbicides have been used against forest croplands and brush along roads and rivers and around military establishments.
- b. A wide variety of chemical substances have been used as herbicides. This chapter will deal with those substances that have been used in admixtures. See Table 9-I.
- c. There is very little likelihood of human beings or animals being poisoned as a result of dioxin-free non-cropland vegetation control. In spraying operations from aircraft, flag-men and women on the ground probably receive relatively high doses, yet a serious case of acute herbicide poisoning has never been confirmed. Poisoning may, however, result from accidental or suicidal ingestion of large quantities of undiluted herbicides. Also important is the fact that toxic residues of these herbicides will not accumulate sufficiently in meat animals to pose a hazard in humans.

*Table 9-I. Composition of Herbicides*

Name	Composition
Compound one	27.7% sodium cacodylate 4.8% cacodylic acid 67.5% water and sodium chloride
Compound two	10.2% tri-isopropanolamine salt of 4-amino-3,5,6-tri-chloropicolinic acid 39.6% tri-isopropanolamine salt of 2,4-dichlorophenoxyacetic acid (2,4,D)* 50.2% unidentified by manufacturer other than for the presence of water and a surfactant
Compound three	50% n-butyl ester of 2,4-D* 30% n-butyl ester of 2,4,5-tri-chlorophenoxyacetic acid (2,4,5-T*) 20% isobutyl ester of 2,4,5-T*
Compound four	50% n-butyl ester of 2,4-D* 50% n-butyl ester of 2,4,5-T*

\* 2,4,-D and 2,4,5,-T may be contaminated with dioxins, some of which are very toxic. Dioxins have been incriminated as a cause of severe choracne in man.



## SECTION II - 2,4-D AND 2,4,5-T

**902. Toxicity.**

- a. The risk of human and animal toxicity from the use of 2,4-D (2,4-dichlorophenoxyacetic acid) and its various esters and salts is low. A useful generalisation for this compound is that the toxicity of its derivatives is about the same as that of the acid equivalent.
- b. 2,4,5-T(2,4,5-trichlorophenoxyacetic acid) is an important chlorophenoxy herbicide widely used as its ester in combination with an ethanolamine salt. From animal studies, it is generally considered to be slightly more toxic than 2,4-D. The biochemistry of 2,4,5-T is probably similar to that of 2,4-D.

**903. Biochemistry.**

Since 2,4-D and its salts, esters, and amides are used for the control of broad leaf plants, its dietary and accumulative effects in the body are important. Long term feeding studies in animals have revealed no evidence that 2,4-D accumulates in the body. The biochemistry of 2,4,5-T is probably similar to that of 2,4-D.

**904. Mechanism of Action.**

The mode of action of 2,4-D is not known. Animals killed quickly by large doses of 2,4-D are thought to die of ventricular fibrillation. Animals poisoned less severely develop a characteristic myotonia which, however, has not been observed in humans. The mode of action of 2,4,5-T is also not known.

**905. Signs and Symptoms.**

- a. Ingestion of a toxic dose of 2,4-D causes gastroenteric distress, diarrhoea, mild CNS depression, dysphagia, and possibly transient liver and kidney damage. Some people have developed neuropathy as a result of skin contact with the compound. Some hours after exposure to the 2,4-D ester or the dimethylamine salt, pain, paraesthesia, and paralysis may develop. The disability may be protracted and recovery incomplete. However, the number of people who have developed neuropathy after exposure to 2,4-D is extremely small compared to the number of exposures that have occurred.
- b. The signs and symptoms of 2,4,5-T poisoning are probably similar to those of 2,4-D poisoning.

**906. Treatment.**

If a toxic dose of 2,4-D or 2,4,5-T has been ingested, further absorption should be prevented by gastric lavage or inducing emesis and administration of activated charcoal. Supportive therapy should be given.

**SECTION III - CACODYLIC ACID****907. Toxicity.**

The toxicity of cacodylic acid, or dimethylarsenic acid, in humans is not known. However, the experience of workers in a chemical company who have had repeated exposures over long periods of time confirms the observation on rats that the toxicity of these compounds is relatively low.

**908. Biochemistry.**

- a. Cacodylic acid is a desiccant that causes leaf drop and death in certain hardwood species. Like 2,4-D and 2,4,5-T, its dietary and cumulative effects are important.
- b. The military herbicide "Compound 1" contains 4.8% cacodylic acid with a trivalent arsenic content of less than 0.1 %. Cacodylic acid has medicinal properties similar to those of inorganic arsenic to which it is partially reduced in the body. However, no reduction to trivalent arsenic occurs.

**909. Mechanism of Action.**

The pharmacologic action of cacodylic acid is intimately related to its biochemistry. The effects of cacodylic acid are essentially those of inorganic arsenic. However, because conversion to arsenic is very slow, its action is more prolonged and considerably less toxic. The local irritant effects of cacodylic acid are minimal compared to those of arsenic. Cacodylic acid is judged as essentially non-irritating to both skin and eyes.

**910. Signs and Symptoms.**

Ingestion of a toxic dose of cacodylic acid by humans may cause slight burning of the mouth and throat, gastroenteric pain, vomiting, diarrhoea, haematuria, albuminuria, dehydration, jaundice, oliguria, and collapse. CNS symptoms (headache, dizziness, and hyperexcitability) may be present, obscuring gastroenteric complaints. Shock may develop as a consequence of paralysis and increased permeability of the capillaries.

**911. Treatment.**

Following ingestion of a toxic dose of cacodylic and further absorption should be prevented by gastric lavage, emesis or activated charcoal. Fluids should be given to combat dehydration.

**SECTION IV - PICLORAM****912. Toxicity.**

Picloram (4-amino 3,5,6-trichloropicolinic acid) is one of the constituents of Compound 2. The major constituent is 2,4-D. Based on the criterion that an acute oral toxicity of 5000

mg.kg<sup>-1</sup> or greater in warm-blooded animals is non-toxic, picloram would be rated accordingly, and Compound 2 would be rated as mildly toxic. The data from extensive animal studies on the acute and chronic toxicity of picloram and Compound 2 suggest there would be little direct hazard of these formulations to humans.

### **913. Mechanism of Action.**

The fate of picloram following ingestion has not been studied extensively and the pharmacology of picloram is unknown.

### **914. Signs and Symptoms.**

As Compound 2 contains 2,4-D isopropyl amine salt, ingestion of a toxic dose would probably produce the same signs and symptoms as are produced by 2,4-D herbicide. Prolonged contact of Compound 2 with human skin will cause mild to moderate erythema. Contact with the eyes can also be irritating.

### **915. Treatment.**

Should ingestion of a toxic dose of picloram occur, further absorption should be prevented by gastric lavage or emesis and by administration of activated charcoal, together with supportive therapy. Washing with soap and water in the event of accidental exposure is recommended. The eyes should be washed thoroughly with water in the event of contamination.

## CHAPTER 10

## RECOGNITION OF A CHEMICAL CASUALTY

**1001. Introduction.**

- a. It is essential that medical personnel are familiar with the signs and symptoms of chemical agent poisoning to avoid repetition of the experience of World War I in which “medical officers frankly admitted that they were so handicapped by their lack of experience of cases of gas poisoning that they were often in doubt whether they were dealing with persons suffering from gas poisoning or not.”
- b. Medical and tactical intelligence channels should communicate with each other as early as possible. Threat information on potential use of CW weapons by enemy forces is important for the planning and execution of medical operations. Once CW weapons have been used, identification of agents will be important to medical intelligence channels for operational purposes.

**1002. General.**

Medical units should rely on information not only from detectors and intelligence sources but also from the casualties themselves. This applies particularly to agents for which at present there is no satisfactory detector, such as incapacitating agents. Some of the problems in the recognition and diagnosis of casualties suffering from the effects of chemical operations are discussed here. Medical personnel must bear in mind that with nerve agents, for example, symptoms and signs may range from mild, such as miosis, headache, and tightness of the chest to signs and symptoms associated with severe poisoning such as convulsions and respiratory failure. The nature and timing of symptoms will vary with the route of exposure. Although choking agents are less likely to be employed, the possibility of their use should not be forgotten, and here the danger is that the quiescent period which follows the initial poisoning might be mistaken for recovery and men or women sent back to duty even after a lethal dose. Battle casualties whose behavioral changes are not compatible with the physical signs of disability must be examined carefully to exclude the possibility of a psychomimetic agent having been used. When chemical agents have been used by the enemy, it is important that the fullest and earliest information be given to medical units to facilitate the diagnosis of individual cases and to permit the arrangements for the reception of casualties.

**1003. Recognition of a Casualty of Chemical Operations.**

Any individual who suddenly becomes a casualty without being wounded or who is suffering a greater degree of incapacitation than is compatible with his or her wound should be considered a possible chemical casualty. The differential diagnosis will include the possibility of psychiatric casualties. It is unlikely that chemical agents would produce single casualties under field conditions and a chemical attack should be suspected with any sudden increase in numbers

of unexplained casualties. If chemical operations are unlikely, and if only a few people are affected, another toxic hazard may be more probable (for example, carbon monoxide).

#### 1004. Questioning Casualties.

Under operational conditions the medical situation may be complicated by the psychological effects. The medical officer's questions should be along the following lines:

- a. Determine whether the casualty has been caused by a chemical agent:
  - (1) Was the casualty wearing full protective equipment at the time of the attack?
  - (2) Were there any aircraft or artillery bombardments in the area at the time of the attack?
  - (3) Was there any evidence of spray, liquid droplets or smoke?
  - (4) Was anybody else affected and if so, how was he or she affected?
  - (5) Did the casualty notice any unusual smell? (This is not a very reliable symptom under battle conditions, but it should be considered.)
  - (6) Did the available detection equipment respond positively?
- b. Determine the identity of the agent:
  - (1) What subjective effects were noticed and how soon?
    - (a) An unexplained sudden runny nose.
    - (b) A feeling of choking or tightness in the chest or throat.
    - (c) Blurring of vision and difficulty in focusing the eyes on close objects.
    - (d) Irritation of the eyes.
    - (e) Unexplained difficulty in breathing or increased rate of breathing.
    - (f) Sudden feeling of depression.
    - (g) Anxiety or restlessness.
    - (h) Dizziness or light-headedness.
    - (i) Slurred speech.
    - (j) Nausea.
    - (k) Muscular weakness.
  - (2) Was there any delay between exposure or contamination and the onset of effects, and if so, for how long?
  - (3) Did the effects persist after adjustment of the respirator?
  - (4) Has the casualty used any self-injection device? If so, did the symptoms improve or deteriorate?
  - (5) Is the casualty's behaviour normal?
- c. Assess the dose of agent received:
  - (1) Was the casualty exercising or at rest?
  - (2) Was the casualty in the open or under cover?
  - (3) For how long was the agent inhaled? How long was the interval between suspected contamination and decontamination?

**1005. Types of Casualties.**

On the chemical battlefield, the following types of casualties maybe seen:

a. *Conventional Casualties.*

- (1) The conventional casualties with no chemical injury and with no contamination of their clothing and equipment.
- (2) The conventional casualties with no chemical injury but with contamination of their clothing and equipment.

b. *Direct Chemical Casualties.*

- (1) The chemical casualty with no other injury.
- (2) The mixed casualty who has a conventional and chemical injury. Since chemical munitions often include explosive burst charges, such injuries may occur as part of a chemical agent attack. They may also occur when the chemical injury and conventional injury occur at different times. Other types of mixed casualties may occur if nuclear or biological weapons are used, and chemical injuries may occur combined with natural illness as well. (Infectious disease still accounts for the majority of casualties in contemporary warfare.)

c. *Indirect Chemical Casualties.*

- (1) *Casualties suffering combat stress reaction (CSR).* Combat stress reaction occurs often in warfare, but maybe more frequent where the chemical warfare threat exists. The soldier will have additional stresses of isolation from wearing the chemical protective ensemble, additional fatigue from wearing the garments and fear of chemical agents. As in World War I, the differential diagnosis between the CSR casualties and chemical casualties may sometimes be difficult.
- (2) *Casualties with side effects from chemical agent antidotes.* Some of the available antidotes may have undesirable side effects when taken inappropriately, or in large enough quantities. Atropine, for instance, causes decreased heat tolerance at a dose of 1 mg. Higher doses may cause tachycardia, dryness of the mouth, and decreased sweating. Medical personnel must be aware of the side effects of the available antidotes and be alert for their appearance.
- (3) *Heat casualty.* Wearing the protective ensemble makes dissipation of excess body heat more difficult. Wearing the mask also makes water intake very difficult. Both will increase the probability of heat exhaustion or heat stroke.

## CHAPTER 11

## MEDICAL SUPPORT IN CHEMICAL OPERATIONS

## SECTION I - INTRODUCTION

**1101. General.**

- a. Medical operations in a chemical warfare environment will be complex. In addition to providing care in protected environments or while dressed in protective clothing, medical personnel will have to treat chemically injured and contaminated casualties, sometimes in large numbers.
- b. A mass casualty situation occurs whenever the numbers or type of casualty exceeds the capabilities of the unit to treat and manage them in a normal fashion. An erroneous reaction to such a possibility is to assume that the problem is too great to cope with and preparations would be futile. Rather, the success of the medical department to function effectively in a chemical war and to treat, successfully, the maximum number of casualties will directly relate to the efforts made in advance to prepare for the possibility.
- c. The doctrine, organisation and equipment available to handle chemical casualties will vary between countries and most particularly between Services, because of differences in military operational requirements. However, whatever the system there will be a common set of problems that must be addressed in the management of chemical casualties because the clinical condition of the casualty will be the same or similar regardless of which Service he or she is a member, and because of similarities in the environment in which the casualty must be treated.

**1102. Objectives of Medical Support in Chemical Operations.**

The objectives are:

- a. To conserve the fighting strength.
- b. To continue to provide medical services and support to the maximum extent possible.
- c. To protect medical personnel from chemical injuries while handling contaminated casualties, or while working in contaminated areas.
- d. To minimise morbidity and mortality from conventional and chemical injuries.
- e. To avoid the spread of contamination into medical vehicles and facilities.

**1103. Characteristics of Chemical Agents.**

- a. The physical characteristics of chemical agents have been described in the individual chapters for each class of chemical agent. These characteristics, the method of employment, and the meteorological environment in which they are used will have a major impact on the type and number of casualties produced.
- b. Some agents, such as nerve agents, cyanide, and phosgene are highly lethal, and a

large proportion of casualties may die unless care is given immediately after an attack. Other agents, such as mustard and Lewisite may be more incapacitating than lethal. The onset of symptoms will differ by type of agent and by route of exposure. Nerve agents and cyanide, especially by the inhalation route of exposure, are characteristically very rapid in onset of effects, whereas mustard and phosgene may have a latent period of several hours between exposure and onset of symptoms. During the latent phase the prognosis and future clinical course will not be apparent and the decision on whether to treat or evacuate will be difficult.

#### **1104. Contamination Control.**

- a. One of the most difficult aspects of chemical warfare is that the chemical agents may persist in the environment for extended periods of time. This is especially true of agents such as VX, the mustards, thickened GB, or GD, which may remain as contact hazards for hours or days.
- b. On the chemical battlefield, three types of environments may exist:
  - (1) An uncontaminated area where there are no chemical agents present.
  - (2) A contaminated area where chemical agents are present in a liquid state (and probably in a vapour state as well) presenting a surface contact hazard.
  - (3) A vapour-only environment, for example, in a downwind hazard area.
- c. Complete decontamination of a contaminated environment may be difficult or impossible. However it may be possible to achieve sufficient decontamination, particularly in small areas, to create a vapour only hazard area. Thus it may be possible to decontaminate equipment so that no further surface contact hazard exists, even though chemical agent vapours may continue to be off-gassed from agent adsorbed onto or absorbed into the surface. In such environments, it may be possible to work without the full protective clothing ensemble, although respiratory and eye protection would still be required. This is because most agents in a vapour state penetrate through the skin very slowly. However, mustard at high vapour concentrations may still cause skin injury, particularly if the skin surface is wet or moist as may be the case in a warm environment.
- d. Where a liquid hazard exists, decontamination of skin and eyes must be accomplished quickly if it is to be effective. Chemical agents may penetrate or react with the skin and eyes within minutes, so successful decontamination must be carried out immediately after exposure. Once agent is decontaminated, or has been absorbed, no further risk of contamination exists. The casualty's body fluids, urine, or faeces do not constitute a CW hazard.
- e. Individual and collective protection are the first line of defence against chemical agent contamination. Individual protection comprises the respirator and protective clothing including gloves and boots. Full protective clothing is particularly important for persistent agents and agents that pose significant skin injury or skin penetration effects. For agents posing a respiratory or eye injury threat exclusively, the respirator would suffice. Individual protection imposes physiological and psychological stress on the individual, impairs communication, and reduces performance to a certain degree, depending on the individual's job performance requirements.



- f. Collective protection is desirable, particularly for medical care. Adequate collective protection may not be possible, or may be difficult to achieve and will require personnel and equipment resources. In some instances, it may be feasible to establish a vapour only hazard area, and work within that area at less than full individual protection, such as using respiratory and eye protection. Limited medical care can be achieved in this manner, but full examination and definitive surgical treatment is impossible without full collective protection.
- g. Collective protection provides the capability to medically manage severely toxic or injured decontaminated casualties in an environment where medical personnel are unencumbered by wearing individual protective equipment. Likewise, the casualties benefit from the capability of the medical unit to make full use of available medical equipment and procedures. A significant percentage of casualties (15-30%) can not be adequately treated in a contaminated environment without collective protection as their treatment requires the removal of their respirator.
- h. In the presence of a CW threat, equipment and supplies should be kept in unopened, sealed or covered containers until required for use. The use of chemical agent resistant material (CARM) will provide good protection against liquid contamination, but even the use of conventional tentage will significantly reduce contamination by a liquid agent for a limited period.

#### **1105. Mass Casualties.**

- a. Chemical weapons may cause large numbers of casualties in poorly protected or untrained personnel. World War I experience showed that large numbers of casualties most frequently occurred with units that were surprised or inexperienced in chemical warfare. Such casualty surges will require careful preplanning and training for medical units if they are to continue to operate efficiently.
- b. All medical units must be prepared to receive mass casualties caused by or contaminated with chemical agents. Mass casualties are considered to be those who are produced within a relatively short period of time and who because of their number and type exceed the medical support capabilities for their care.
- c. Casualty sorting must take into account the possibility that some casualties may be contaminated. Some provision for emergency treatment of contaminated casualties needs to be made, since some critical care may be required before decontamination can be accomplished. Proper triage procedures are an essential element in handling large surges of casualties. (See Paragraph 1107.) With adequate advance planning and training, mass casualty situations can be managed and excessive morbidity and mortality reduced. Lack of such preparation, or a mistaken belief that such preparations are futile, are sure ingredients for disaster.

#### **1106. Medical Decision Making.**

- a. Differential diagnosis is one of the first and most difficult aspects of managing chemical casualties. Unless it is known to which agent the casualty was exposed, it may be difficult to establish a diagnosis with certainty. Further, the casualty may

still be partially or fully encapsulated in a protective ensemble, precluding elucidation of any but the most simple signs and symptoms. Knowledge of the principal signs and symptoms is necessary to determine the clinical diagnosis. The rapidity of the onset of symptoms may be an important clue, for example in nerve agent poisoning or cyanide poisoning. In some instances, it is better to act rather than try to obtain a certain diagnosis, particularly if the condition of the casualty is serious and rapidly deteriorating. In forward treatment areas, the diagnosis should be kept as simple as possible, and be keyed to making decisions that will lead to some specific action or actions.

- b. When chemical casualties are received at a medical unit, they may also have traumatic wounds or illnesses due to other causes. These patients must be managed so as to minimise the injuries resulting from chemical exposure without aggravating their traumatic wounds or illnesses.

### 1107. Triage.

- a. Triage is one of the most important tools for handling combat casualties, particularly in mass casualty situations. Basically, it is a medical decision process used to arrange casualties in priority order to ensure the most effective use of limited medical resources and minimise morbidity and mortality. Triage is a continuous, ongoing process through the casualty care chain and should be utilised whenever casualties must be assigned priority for treatment, evacuation or decontamination. Triage decisions should be made by highly experienced personnel familiar with chemical and conventional injuries. Triage criteria should be determined in advance and practised. They must be relevant to the medical capabilities of the medical unit. The four standard NATO mass casualty triage categories, adapted for chemical casualties, are as follows:

- (1) *Immediate treatment (T1)*. This includes those requiring emergency life saving treatment. Treatment should not be time consuming or require numerous, highly trained personnel, and the casualty should have a high chance of survival with therapy.
- (2) *Delayed treatment (T2)*. The general condition permits some delay in therapy although some continuing care and relief of pain may be required before definitive care is given.
- (3) *Minimal treatment (T3)*. This includes those with relatively minor signs and symptoms who can care for themselves or who can be helped by untrained personnel.
- (4) *Expectant treatment (T4)*. This group is comprised of patients whose treatment would be time consuming, require numerous highly trained people, who have life threatening conditions beyond the treatment capabilities of the medical unit, and would have a low chance of survival. It must be noted that the decision to place a casualty in the expectant category is not necessarily a decision to render no therapy. Rather, the triage categories determine the priority in which casualties are treated.

- b. Chemical poisoning, besides being difficult to treat in itself, will complicate the therapy for other conditions. The addition of antidote therapy may further complicate management of other conditions requiring drug therapy, e.g., use of muscle relaxants for surgery or the use of analgesics. Some of these drug interactions are currently unknown, and the medical staff must remain alert for unusual reactions to otherwise common therapy on the battlefield.

## SECTION II - CASUALTY MANAGEMENT PHASES

### 1108. General.

- a. *Field Medical Operations.* Field medical operations are conducted with several echelons of care, with increasing capabilities, and more sophisticated equipment towards the rear. The most forward medical support is usually provided by enlisted medical personnel with limited equipment, drugs, and medical capabilities.
- b. *Far Forward Treatment.* Major advances have been made in casualty survival by advances in medical and surgical capability, and most importantly by advances in rapid evacuation and early stabilisation of casualties. On the chemical battlefield, early treatment and stabilisation will be particularly critical, since the lethal agents have very rapid onset of severe, life threatening effects. This means that far forward treatment, often by non-medical personnel, will be of even greater importance than in conventional warfare.
- c. *Casualty Care Systems.*
  - (1) A specific example of a casualty care system is described in AMedP-7(A), Concept of Operations of Medical Support in a Nuclear, Biological and Chemical Environment. Because the mission requirements of each Service differ markedly, the organisation of medical support, the types and amount of medical resources at the echelons, and the evacuation distances between echelons will differ greatly. Further, there will be other national differences, such that the description of a particular system will not coincide with other national or Service systems.
  - (2) However, when the necessity of certain functional capabilities to handle different systems is considered, important similarities between the different systems can be identified. Nine functional phases of casualty care have been identified. Not every casualty will pass through all phases. Further, some phases such as evacuation, may be performed several times. Although the phases are arranged in order, the exact temporal order may vary from system to system, or be modified by force of circumstances. The first three phases, pre-attack, self aid and buddy aid will be carried out by non-medical personnel in the units themselves. The remainder of the phases will generally be carried out by medical personnel and units.

**1109. Phase I - Pre-Attack.**

- a. The steps taken before an attack occurs will be the most important in determining how many and how severe the casualties will be. The protective mask and clothing are the first line of defence. Some nations have pre-treatments available for protection against certain chemical agents. Training will be essential to maximise protection of personnel and equipment. With multiple dose pre-treatments, strict discipline to ensure proper use will be necessary. The immediate commander exercises primary responsibility for ensuring that all necessary steps are taken. Medical personnel have a staff advisory role to the commanders in assisting them on matters of medical importance. For instance, commanders need to be advised of the physiological stress characteristics of the protective ensembles and how performance capabilities may be altered. The relation between environmental temperature and heat stress needs to be emphasised, especially in training situations, to avoid unnecessary heat casualties. Medical units will generally follow the same training and procedures for protecting themselves as do the non-medical units.
- b. An example of possible guidance given for the prevention of heat casualties is given in Paragraph 1127. Each country may wish to issue its own specific guidelines.

**1110. Phase II - Immediate Post-Attack/Self Aid.**

- a. The goal in this phase is to protect oneself from agent exposure during and immediately after an attack, to stop any further exposure, or to initiate immediate therapy if a significant exposure has occurred.
- b. Since it is by definition “self care,” it is carried out only by personnel still capable of functioning. For agents with rapid onset, some personnel may not have time to take any steps before they are severely incapacitated and will by definition not pass through this phase. Since personnel in this phase will still be able to function to a certain degree, it is important that any treatment that they take not be incapacitating in itself. Some individuals will take such self aid mistakenly when they have not had a significant exposure, or even deliberately. Since the preservation of the unit effectiveness is most important at this point, additional casualties from the antidotes must be avoided.
- c. The specific antidotes available for self care are discussed in the chapters for the different classes of agents, and are further prescribed in national and service doctrines. The specific steps in self-administration of the antidotes are likewise part of national and service doctrine and training. A critical factor in use of self aid antidotes is clearly defining the specific conditions under which they will be taken. Most commonly, they are taken when the individual notices a specific set of symptoms, characteristic for the agent. Additionally, self decontamination kits and their use are described in national and service doctrine.

**1111. Phase III - Buddy Aid.**

- a. Buddy aid is the care given by non-medical personnel to personnel who are not able to care for themselves. Incapacitation of various degrees is the marker differentiating between self care and buddy care.
- b. Many units do not have medical personnel assigned or attached, or the medical personnel themselves may be casualties. Since immediate care is often so important in treating chemical casualties, buddy care will be the determining factor in the success of treatment. Unit commanders must take considerable care to ensure that all personnel have a adequate training to perform buddy care for chemical agent casualties. Such training is essential since the normal instinct of soldiers to help one another may be hampered by the inability in protective clothing to recognise that help is needed. Medical personnel may assist commanders in providing training.
- c. Since the numbers of medical personnel are limited, particularly in forward units, commanders may wish to have a few non-medical personnel trained to a higher level of medical proficiency than would be feasible for all personnel. This could be valuable in resuscitation of nerve agent casualties for example, where the procedures are more complex. Such trained personnel would also provide back-up for medical personnel who may become casualties.
- d. The antidotes available for buddy care will usually be the same as those provided for self aid. Since the casualty will be already incapacitated, the concern for further incapacitation from antidotes no longer applies, and further or higher doses of antidotes may be given if available. The individuals providing buddy care should not use their own antidotes to treat a casualty since they may need it themselves, but should use those belonging to the casualty, or any others available.
- e. Commanders will have to exercise some control on buddy care, so as not to compromise mission accomplishment, but must also recognise their exclusive responsibility for the welfare of the casualties while they are still in the commanders' units. Manpower intensive procedures such as resuscitation must be applied judiciously, and only to those likely to benefit in order to avoid tying up too many personnel. Similarly, casualty evacuation out of the unit often requires the unit's own personnel initially and must be tightly controlled to retain personnel within the unit. Again, unit survival must be the overriding consideration.

**1112. Phase IV - Initial Medical Care.**

- a. Initial medical care is the first care given by medical personnel. Although for administrative reasons medical care is sometimes defined as beginning when a casualty is treated by medical personnel, from a functional consideration medical care should be a continuous process, and this phase is a continuation of care given in preceding phases.
- b. The goals of the initial medical care are to return to duty promptly all personnel still effective, and to stabilise and prepare for evacuation those casualties who require further medical care. Even though the medications, equipment, and medical personnel resources available far forward are limited, this phase will still be highly

critical for successful outcome. As a result of certain agents, casualties reaching this point may be severely incapacitated. Triage will be important in determining priorities of care and evacuation. The specific therapy available in this phase will depend on the unit, national and Service doctrines, and policies.

### **1113. Phase V - Life Support/Stabilisation.**

Given the rapid onset and severe course of poisoning by some of the chemical warfare agents, nerve agents in particular, consideration for life support of vital, cardiovascular and respiratory function will often be required. Other conditions such as hemorrhage or shock from conventional wounds will also require immediate care. The ability to successfully manage these conditions will depend on the resources available at the various echelons. Triage criteria may dictate that some of these casualties will have a low priority of care. However, it is vital to make some effort to stabilise a casualty before evacuation to higher echelons and some effort at stabilisation should precede time consuming efforts such as full casualty decontamination. Therefore, some means of handling severe casualties should be incorporated early on in the system of managing casualties at each echelon. Hemorrhage, severe respiratory distress, cardiovascular collapse, shock, and seizures are among the conditions requiring prompt attention.

### **1114. Phase VI - Evacuation.**

Evacuation of chemically injured casualties entails more than transportation. Monitoring is important to ensure that the casualty's condition is not deteriorating. Some provision for in transit care will also be critical. Since some casualties may be contaminated, the casualty evacuation system must be organised in a way as to minimise the spread of contamination. Since mass casualties may occur, and the number of medical vehicles may be inadequate to meet the increased load, unit commanders need to have contingency plans to supplement medical vehicles for casualty evacuation, or be prepared to retain casualties within their units for longer periods of time. Aeromedical evacuation is desirable when feasible, but the combat situation, the chemical environment and the possibility of contaminating helicopters may preclude their use far forward, in the initial stages of evacuation.

### **1115. Phase VII - Casualty Decontamination.**

- a. The goal of casualty decontamination differs from personal and unit decontamination. In addition to preventing exposure of the agent, casualty decontamination also has the goal of preventing exposure of medical care personnel and facilities to contaminated casualties. The requirement for casualty decontamination will be a function of the agent used, environmental factors, and particularly time. Liquid chemical agents on the skin may react with, or penetrate it rapidly. Some method of monitoring contamination would be valuable in determining the degree of decontamination required.
- b. It is imperative that at least limited decontamination is performed as soon as possible. This will diminish the chance of recontamination of the casualty, or contamination of medical personnel and facilities from any agent left on the clothing or equipment.

Given the time it takes to evacuate casualties, the quantity of liquid agent on the skin or clothing will have diminished or even disappeared due to evaporation. Often careful removal of the clothing and equipment, with spot decontamination of skin areas that may be at risk of recontamination when the clothing is removed, will be just as effective as full decontamination, and can be accomplished more quickly and with fewer personnel. Protecting the wound from any further contamination with protective dressings is desirable. Further management of wounds should follow normal treatment procedures.

- c. The hazard of off-gassing and further contamination from clothing and equipment removed from contaminated casualties requires that these items be disposed of properly. Several methods may be utilised for this purpose, such as impermeable bags or containers, or bleaching powders.
- d. Disposal sites for these items must be marked in accordance with the standard NATO markings.

### **1116. Phase VIII - Definitive Care.**

Specific therapy of the chemical casualty should be initiated as far forward as possible. It may occur across several echelons of care, involving increasingly sophisticated medical treatment as the casualty is evacuated to the rear.

### **1117. Phase IX - Disposition.**

Following successful medical intervention, it must be decided whether a casualty should be returned to duty, held, or evacuated further to the rear for further treatment and convalescence. For casualties with minor exposures, it is desirable to return them to duty as soon as possible, and as far forward as possible, although this is not always operationally feasible. For casualties with severe poisoning, the course may be prolonged, and a long convalescence may be expected. The disposition of mustard injuries is dependent not only on the extent of injury, but also on the site of injury, as is described in Chapter 3. Care must be exercised in early mustard or phosgene injuries not to confuse the latent period with absence of injury. Nerve agent casualties with depleted cholinesterase levels are likely to be more susceptible to subsequent poisoning from nerve agents until their cholinesterase levels return to normal.

## **SECTION III - COMBINED INJURIES**

### **1118. Introduction.**

- a. Combined injuries occur when a casualty is affected by conventional weaponry and also by the use of nuclear, chemical or biological weapons. The situation in which a casualty is contaminated with a chemical agent, but not suffering from such an agent's effects is dealt with in AMedP-7(B).
- b. Wounds which are not contaminated should be dressed in the usual way. They should then be covered with agent proof material (either impervious material or material similar to that of the protective suit) and any pressure bandage considered necessary

may then be applied over the protective covering. These precautions may prevent the casualty becoming a mixed chemical and conventional casualty.

- c. The object of this section is to consider the effect of poisoning by chemical agents, and the effect of drugs used in the treatment of such poisoning upon the handling and treatment of casualties who are suffering from conventional wounding. A summary of possible interactions is listed in Table 11-I.

*Table 11-I. Potential Interactions of Chemical/Conventional Injuries*

Chemical agent group	Potential interaction
Nerve agents (carbamate pre-treatment (atropine))	Relaxants in anaesthesia. Resuscitation. Narcotic analgesics. Blood loss. Shock.
Vesicants (mustard and arsenicals)	Slow healing of wounds. Haematopoietic depression. Infection more likely.
Lung damaging agents	Resuscitation. Blood loss. Shock (latent period may be shorter).
Cyanogen agents	Resuscitation. Narcotic analgesics. Blood loss. Shock.

#### SECTION IV - NON PERSISTENT AGENTS

##### 1119. Injury Complicated by Exposure to a Non Persistent Nerve Agent.

- a. The dangers presented by this form of combined injury are those of the nerve agent itself, those of the interaction of respiratory depression with the conventional injury and those of the reduced cholinesterase activity upon drugs used in anesthesia during subsequent surgery; even carbamate pre-treatment may affect muscle relaxants to a limited extent.
- b. Signs of nerve agent intoxication will call for treatment as described in Chapter 3.
- c. Loss of blood will complicate respiratory failure, so that the administration of oxygen, if available, and positive pressure resuscitation if necessary, should be applied at the earliest indication of need. The need for replacement of blood lost through conventional injury will be correspondingly greater if respiratory depression is present. Reduced cholinesterase activity will affect the use of relaxant drugs used during anesthesia. On basic principles the action of anticholinesterases (including



to a lesser extent pyridostigmine pre-treatment) may be expected to potentate the action of depolarizing relaxants (e.g., succinylcholine) prolonging their action, but to oppose the action of non-depolarising relaxants of the curare type increasing the necessary dose. Drugs, such as opiates and other drugs, which reduce respiratory drive should be used with caution in cases of nerve agent intoxication.

#### **1120. Injury Complicated by Exposure to Lung Damaging Agents.**

- a. This form of combined injury increases the stress element involved in the induction of pulmonary oedema. The latent period between exposure and the development of pulmonary oedema may possibly be shortened and the pulmonary oedema itself may be more severe.
- b. The casualty should be kept at rest as far as possible during evacuation and steroid treatment if used should be applied at the earliest moment. There is no contra-indication to the use of opiates or other systemic analgesics in order to treat pain or shock from the conventional injury. Oxygen therapy may be required, but fluid replacement should be used with caution. The final decision on the necessity for fluid replacement must be made on the basis of the casualty's condition, bearing in mind the danger of precipitating or increasing pulmonary oedema.

#### **1121. Injury Complicated by Exposure to Cyanogen Agents.**

- a. Combined injuries of this type will present especial danger from respiratory depression and from the therapeutic reduction of the oxygen carrying power of the blood, owing to the formation of methaemoglobinaemia in treatment.
- b. The need for treatment of cyanide poisoning is urgent and must be started in accordance with Chapter 5. Oxygen therapy together with positive pressure resuscitation may be required all the more urgently in the presence of marked hemorrhage.
- c. Opiates and other drugs which reduce respiratory drive must be used with caution in these combined injuries as the respiratory centre is depressed in cyanide poisoning.

### **SECTION V - PERSISTENT AGENTS**

#### **1122. Injury Complicated by Persistent Nerve Agents.**

- a. Where the conventional injury is itself contaminated by a persistent nerve agent the danger of the casualty absorbing a lethal dose of nerve agent through the wound is very great and the prognosis is correspondingly bad. Although the wound track resulting from a conventional weapon injury is surrounded by devitalised tissue, there is rapid penetration of the tissues by nerve agent and a lethal dose may be quickly absorbed especially if a persistent agent contaminates the wound.
- b. Decontamination of the skin surfaces around the wound should be carried out and then a surface dressing applied. The wound itself should be protected from further contamination and the integrity of the suit restored. Wounds may be irrigated using

- a solution of hypochlorite and then flushed with normal saline. Hypochlorite should not be used, however, within the abdominal or thoracic cavities, nor with intracranial wounds. Early surgical excision of the contaminated wound may offer the best chance of success but autoinjector treatment should be started immediately the wound contamination is diagnosed and repeated as necessary.
- c. Surgery of the contaminated wound offers minimal danger to medical and nursing staff if gloves made of butyl rubber are worn. If these are not available then two pairs of latex rubber gloves should suffice if washed at short intervals in hypochlorite solution and changed frequently. The evacuation of casualties with combined injuries requires careful observation while on route to a surgical unit and autoinjector treatment continued if signs of poisoning persist or worsen.
  - d. For conventional wounds not directly contaminated but with the surrounding skin affected by a chemical agent, decontamination of the skin should be carried out and any poisoning treated as appropriate for the particular agent involved.
  - e. Where the conventional injury is not directly contaminated, but skin absorption is thought to have occurred, skin decontamination should be carried out in the recommended way. Any signs of nerve agent intoxication should be treated. The casualty should be kept under as close observation as circumstances allow in case signs of delayed absorption of agent appear. If it is necessary to evacuate without medical supervision, consideration may be given to the use of one injection from the automatic injection device as a precaution against delayed absorption of nerve agent.

### **1123. Injury Complicated by Contamination with Vesicant Agent.**

- a. Vesicant agents will debilitate the casualty and may seriously delay the healing of any wound due to systemic effects, even if the wound itself is not directly contaminated. A contaminated wound will be very slow to heal and may also lead to rapid systemic absorption of the agent.
- b. If the contamination of a wound with Lewisite occurs (immediate pain, disproportionate to the severity of the wound is suggestive of this) therapy with dimercaprol (BAL) will be required at an early stage.
- c. The area around the wound should be decontaminated and the wound dressed. The dressed wound should be protected from further contamination with material similar to that of the protective suit.
- d. Thickened mustard may be carried into wounds on fragments of cloth. These wounds should be carefully explored using a no-touch technique. Fragments of cloth should be removed and placed in a bleach solution. This removes the hazard from mustard vapour off-gassing. Wounds should be irrigated using a solution containing 3000-5000 ppm free chlorine (dilute "milton" solution) with a dwell time of approximately 2 minutes. The wound should then be irrigated with saline. This technique should not be used in the abdominal, or thoracic cavities, nor with intracranial head injuries.
- e. Opiates should not be withheld if the condition of the casualty calls for their use.

## SECTION VI - OTHER CONSIDERATIONS

**1124. Collective Protection.**

Collective protection greatly enhances the treatment of casualties in a contaminated environment as 15-30% of casualties can not be adequately treated without removal of their respirator.

**1125. Head Wounds.**

Head wounds, after being attended to and dressed will necessitate the casualty being evacuated in a casualty bag or half bag or hood. In emergency the casualty's head may be protected in a pervious blouse from a spare protective suit.

**1126. Heat Stress.**

- a. The use of individual protective equipment and casualty bags imposes a significantly greater heat stress upon the individual. In warm environments and at moderate work rates personnel are susceptible to heat injury.
- b. The medical officer's responsibilities may include providing advice to commanders about work/rest cycles and of the need for increased fluid intake.
- c. Medical attendants need to be especially aware of the need to replace fluids in casualties wearing individual protective equipment.
- d. Protective equipment makes monitoring casualties difficult and a high index of suspicion for heat stress must be maintained at all times.
- e. Table 11-II may be applied as guidance for the prevention of heat casualties in acclimatised individuals. In situations where work is heavy or prolonged, the risk of heat injury exists at wet bulb gradient temperatures (WBGT) below 78°F (25.5°C).

*Table 11-II. Heat Casualty Prevention Guide*

Heat condition (category)	WBGT index* (°C)	Water intake (liters per hour)	Work/rest cycle (minutes)	WBGT index* (°F)	Water intake (US pints per hour)
1	25.5 to 27.6	At least 0.45	Continuous	78.0 to 81.9	1
2	27.7 to 29.3	At least 0.45	50 / 10	82.0 to 84.9	1
3	29.4 to 31.0	At least 0.9	45 / 15	85.0 to 87.0	2
4	31.1 to 32.1	At least 1.4	30 / 30	88.0 to 89.9	3
5**	32.2 and above	More than 1.8	20 / 40	90.0 and above	More than 4

\* Individual protective gear or body armour adds at least 6°C (10°F) to the WBGT index.

\*\* Suspend physical training and strenuous activity. If operational mission (non-training) mission requires strenuous activity, enforce water intake to minimise expected heat injuries.

## CHAPTER 12

## DISPOSITION OF CONTAMINATED FOOD AND WATER

## SECTION I - GENERAL

**1201. Introduction.**

- a. Although it is expected that chemical agents will be used mainly against personnel, food and water supplies may easily become contaminated and may be contaminated deliberately. This may occur from contact with chemical agents in the form of vapour, aerosol, drops or splashes of liquid or particulate smokes. This may render food both unpalatable and toxic, but on the other hand, dangerously contaminated food may appear normal.
- b. Decontamination of food is difficult and often impossible, so that all food not packed in agent proof containers must be stored under protection. When decontamination of food is possible, the decision to undertake decontamination must depend on local factors, for example, the availability of new food.
- c. Food supplies in storage are not likely to be seriously contaminated if precautions are taken to protect them against chemical attack. For this reason, large supplies of food should not be condemned as a whole, simply because they have been exposed to possible chemical contamination. A prompt and careful survey of the supplies may reveal only a few items have been so contaminated and require special treatment. Prompt segregation of the heavily contaminated portions will prevent or minimise contamination of the remainder. Generally, foods not packed in protective packages constitute the major difficulty. The type and extent of contamination, the availability of replacement supplies, and the available means of decontamination will dictate whether or not reclamation of contaminated items is worthwhile.
- d. Water is liable to contamination and may be contaminated deliberately. There are several methods of decontamination. Water is likely to be in short supply, and is more immediately important to the body than food, so that methods of protection, control and decontamination of water must be considered.

## SECTION II - EFFECTS OF CHEMICAL AGENTS ON FOOD AND WATER FOOD

**1202. General.**

The effects of chemical agents on food depend on the properties of both the agent and the food. Contamination of water may lead to a toxic hazard when it is used for food preparation.

**1203. Penetration.**

Nerve and mustard agents readily penetrate fatty foods and will also penetrate granular foods (e.g., grain and sugar). Arsenical penetrate proteins less readily owing to their coagulating

action. Fruit may be penetrated by nerve agents. Three groups of foods may be considered on the basis of their composition.

- a. Foods with high water content, but low fat and a crystalline structure (e.g., fresh vegetables, fruit, sugar and salt). These absorb mustard and nerve agents in vapour and in liquid form.
- b. Foods with low fat content and amorphous structure (flour, bread, grain, rice cereals, dried fruit and vegetables, tea, coffee, peas and beans). These absorb liquid nerve and mustard agents; some absorption of vapour may occur.
- c. Foods with high fat and low water content (butter, fat, oil, ham, fat meat, cheese, milk, eggs and fish). These absorb nerve agents and mustard so readily that decontamination is impossible.

#### 1204. Effect on Food.

- a. *Food may become highly toxic without any change in its appearance.*
- b. The expected effect of some chemical agents on the appearance of food are summarised in Table 12-I. The absence of these signs must *not* be relied upon in deciding that exposed food is fit for consumption. (See Table 12-II.)

*Table 12-I. Effect Of Certain Agents On The Appearance of Food*

Agent	Taste	Smell	Colour	Residual toxicity
Mustard	Affected	Garlic	Meat discoloured	+
N-Mustards	Affected	Fishy	No discolouration	+
Arsenicals	Acid	Unpleasant	Meat & vegetables discoloured	+
Nerve agents	None	None	No effect	+
White phosphorus	Acid	Garlic	Glow in dark	+

#### 1205. Effect on Crops.

Heavy contamination of plants with mustard or arsenical will destroy crops. Lighter contamination may cause partial defoliation. Arsenical agents will leave sufficient arsenic to render the plant toxic, and nerve agents may penetrate plants so as to make them toxic.

**1206. Effect on Livestock.**

The effects of chemical agents on livestock will be the same as those upon human casualties apart from species specific variations. Mustard does not cause blistering in animals. The presence of large numbers of dead animals may indicate contamination in the area and these animals should not be eaten.

*Table 12-II. Effect of Chemical Agents on Food*

Type of agent	High fat content (butter, fats, cheese, meat, bacon and shell eggs, etc.)	Low fat, high moisture content (fruit, vegetables, sugar, salt, etc.)	Low fat, low moisture content (cereal, tea, coffee, flour, bread, rice, etc.)
Nerve agents (liquid)	Condemn.	Condemn.	Condemn.
Nerve agents (vapour)	Condemn.	Expose dry food to the air for 48 hours. Wash other foods with 2% sodium bicarbonate solution, peel where applicable, and cook by boiling.	Expose dry food to the air for 48 hours. Wash other foods with 2% sodium bicarbonate solution, peel where applicable, and cook by boiling.
Blister agents (liquid)	Condemn.	Condemn.	Condemn.
Blister agents (vapour)	Condemn.	Expose dry food to the air for 48 hours. Wash other foods with 2% sodium bicarbonate solution, peel where applicable, and cook by boiling.	Expose dry food to the air for 48 hours. Wash other foods with 2% sodium bicarbonate solution, peel where applicable, and cook by boiling.
Choking agents*	Wash food with water where possible and expose to the air for 24 hours. Food may be unpalatable due to the acid product of hydrolysis.	Wash food with water where possible and expose to the air for 24 hours. Food may be unpalatable due to the acid product of hydrolysis.	Wash food with water where possible and expose to the air for 24 hours. Food may be unpalatable due to the acid product of hydrolysis.
Cyanide type agents	Unlikely to produce dangerous contamination of foodstuffs.	Unlikely to produce dangerous contamination of foodstuffs.	Unlikely to produce dangerous contamination of foodstuffs.
Riot control agents	Food may be unpalatable to the extent of being inedible.	Food may be unpalatable to the extent of being inedible.	Food may be unpalatable to the extent of being inedible.

\*Agents decompose rapidly on contact with water.

**SECTION III - PROTECTION OF FOOD AND WATER AGAINST CONTAMINATION WITH CHEMICAL AGENTS**

**1207. Packaging Materials.**

*Decontamination of food is difficult and not likely to be satisfactory, so that the protection of food and drink is of the first importance.* Food supplies should therefore always be covered when transported or stored. Even the thinnest covering is better than no covering at all, but good protection can be given by suitable methods of packing and storing.

**1208. Disposition of Packaged and Stored Supplies.**

In determining the disposition of packaged and stored supplies which have been contaminated, consideration must be given to the nature of the contaminant, as well as to the type of foodstuffs and the security afforded by the packaging material. Some of these factors are outlined below:

- a. Airtight glass bottles, sealed aluminium laminated packages, and sealed metal cans give complete protection against vapour and liquid.
- b. Wooden boxes not sealed for the exclusion of air give almost no protection against vapour and liquid.
- c. Waxed paper boxes sealed for the exclusion of air give good protection against vapour and fair protection against liquid.
- d. Untreated wrapping papers give poor protection against vapour and very little against liquid.
- e. Ordinary textiles in a single layer packaging give almost no protection against vapour and liquid.
- f. Coverings of sod and earth give good protection against vapour and liquid.
- g. Overhead shelters give protection against liquid sprays and splashes. Closed buildings give protection against liquids but often not against vapours, unless overpressured with filtered air.
- h. Generally, double layers greatly increase the protective efficiency of packaging materials.
- i. Field rations are packaged to protect the enclosed foods for hours even when the outside of the package is heavily contaminated with a liquid agent.

**SECTION IV - MONITORING FOR CONTAMINATION****1209. Monitoring Food.**

- a. *All food exposed to chemical attack which has not been protected by agent-proof containers or in fully protected stores must be considered contaminated.*
- b. Monitoring for *volatile agents* only may be undertaken by putting the food into a clean plastic bag and sampling the air in the bag with suitable detection equipment.
- c. Where arsenical contamination is suspected, the food may be suspended in water and the water tested with a water testing kit. Liquid contamination on the surface of containers may be tested for using detector papers, but this method will only be reliable whilst liquid agent remains.
- d. *Mental incapacitants, biological agents and nuclear fallout will not be detected by these means.*



## SECTION V - DECONTAMINATION OF FOOD AND WATER

**1210. Classification of Supplies.**

Before any decontamination is done, a careful survey should be made to determine the extent of the contamination. From information gained in this survey, the exposed items should be divided into three groups for separate treatment as described below.

- a. Group I will consist of canned and unopened packaged items which have been exposed only to the vapours of a chemical agent. Generally, the items in this group will be safe to issue to personnel after a brief period of outdoor airing to remove clinging vapours.
- b. Group II will consist of canned and unopened packaged items, the outsides of which have been contaminated with a liquid chemical agent. The best procedure is to allow self decontamination of the packaging material by ageing and airing. If a shortage of food does not permit the necessary time for self decontamination, then a decontamination procedure is to strip off the outer contaminated coverings and examine the inner layer to see if agent penetration has occurred. If it has, continue stripping off layers until an uncontaminated layer is reached.
- c. Group III will consist of unpackaged or poorly packaged items which have been exposed to an agent in either vapour or liquid form. Decontamination of food itself will be attempted only in emergency situations when there is no alternative supply of food. The general decontamination procedure to be followed in sequence is:
  - (1) Trimming of surface fat and/or grossly contaminated areas.
  - (2) Washing with water of 2% sodium bicarbonate solution or 1% chlorine solution.
  - (3) Boiling in water. Frying, roasting or boiling will not remove traces of nerve or blister agents from meats. In general, salvage of foods contaminated with droplets of the blister agents, especially the arsenical blister agents, is not practical.

**1211. Water.**

- a. Contamination of water may lead to a toxic hazard when it is used for drinking, washing, and food preparation.
- b. Although many agents hydrolyse in water, this is not satisfactory as a method of decontamination. Arsenical agents leave degradation products which are toxic even when hydrolysis is complete. The appearance of water does not indicate contamination, and any water exposed to high concentrations of vapour, or any liquid contamination must be regarded as toxic until tests have been made.
- c. Open water sources subjected to chemical attack should be considered contaminated until tested. Water from deep wells will be safe provided that the well mouth is covered. Water in closed metal tanks will be safe provided that the tap and air inlet are decontaminated. Table 12-III gives the maximum allowable concentrations for certain agents in accordance with Stanag 2136.

*Table 12-III. Maximum Allowable Concentrations of Agents in Drinking Water*

Agent	Maximum Allowable Concentration (mg.l <sup>-1</sup> ) consumed at 5 litres per day for not more than 7 days
Mustard	0.2
Nerve agents	0.02*
Arsenic	0.3
Cyanogens	6.0

\* Many water testing kits are not sufficiently sensitive to detect nerve agent at this concentration.

**1212. Monitoring Water.**

- a. Water testing kits will detect the following agents: mustard, nerve agents (0.05 ppm only), arsenic, antimony, cyanogen agents, other heavy metals (lead, copper, mercury). Water with a pH less than 3 is condemned since this high acidity may be due to contamination with mustard, but if free chlorine is present throughout 30 minutes mustard will be destroyed. Chlorine in excess of 5 ppm will, however, interfere with the testing and should be reduced (e.g., with thiosulphate).
- b. The water testing kits will not detect mental incapacitants, biological agents or nuclear fallout.

**1213. Decontamination of Water.**

*Simple boiling is not a reliable method of decontamination.* The following methods are available for decontaminating water and may be used in combination:

**a. Filtration.**

- (1) In a small scale emergency, water may be decontaminated by running it through a spare unused respirator canister, provided that the flow rate is such that the water emerges drop by drop; any water coming through at first faster than this should be discarded. No more than 5 litres should be filtered with one canister. *The canister cannot be used on a respirator after being used for this purpose.*
  - (2) On a larger scale, a modified water purification unit in which the kieselguhr filter is supplemented by a bed of activated charcoal is under development.
- b. Superchlorination.** Small amounts of water, in units of one litre, may be superchlorinated. Simple chlorination, as is used to disinfect water from naturally occurring bacterial contaminants, is not sufficient to decontaminate water suspected of being contaminated with chemical agents.

- c. *Flocculation.* Larger quantities of water may be treated by flocculation with metal salts, after which the water is treated with chlorine.
- d. *Reverse Osmosis.* Reverse osmosis is an effective method of removing contamination, including heavy metals.

**NATO HANDBOOK ON THE MEDICAL ASPECTS  
OF NBC DEFENSIVE OPERATIONS  
AMedP-6(B)**

**PART III- CHEMICAL**

**ANNEX A**

**BIOCHEMICAL ACTION OF NERVE AGENTS**

**1 FEBRUARY 1996**

**TABLE OF CONTENTS**

		Page
Paragraph	A.01. Acetylcholinesterase	A-3
Figure	A-I. Hydrolysis of Acetylcholine	A-3
	A-II. Overall Reaction Occurring During Hydrolysis of Acetylcholine	A-4
	A-III. GB and AChE Reactions	A-4

ANNEX A

BIOCHEMICAL ACTION OF NERVE AGENTS

A.01. Acetylcholinesterase.

- a. Acetylcholinesterase exists as a large, complex molecule. The active centre has been suggested to comprise:
  - (1) A negatively charged or anionic sub-site.
  - (2) An esteratic sub-site.
- b. The current model for the binding group at the esteratic site is an hydroxyl group of a serine molecule of the enzyme. This group binds to the acyl carbon atom of acetylcholine. The sequence of reactions taking place during the hydrolysis of ACh is shown in Figure A-I.

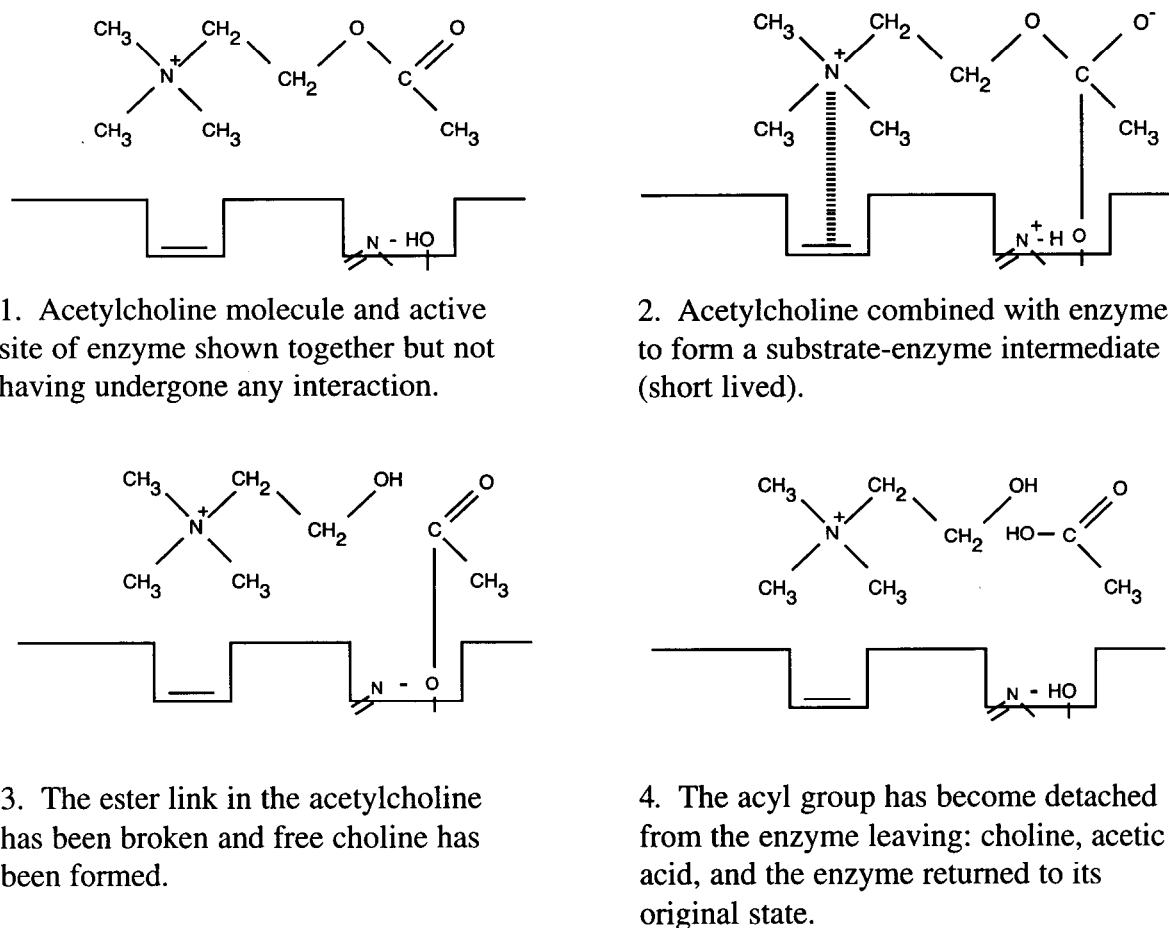


Figure A-I. Hydrolysis of Acetylcholine

c. The overall reaction could be represented by Figure A-II.

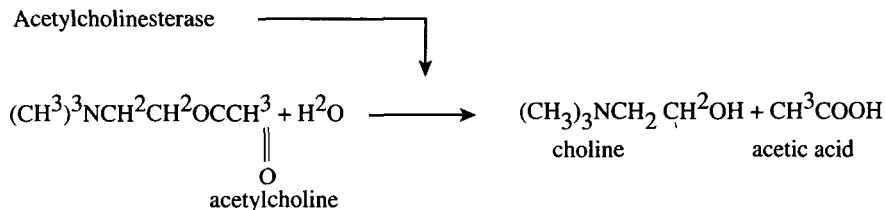


Figure A-II. Overall Reaction Occurring During Hydrolysis of Acetylcholine

- d. The choline is taken up by the pre-synaptic or pre-junctional nerve terminals and recycled by combination with acetyl COA catalysed by the enzyme choline acetyltransferase to form more acetylcholine.
- e. The destruction of acetylcholine by Ache is a very rapid reaction. Organophosphorus compounds (including the nerve agents) act by combining essentially irreversibly with acetylcholinesterase molecules and preventing their activity. The combination of GB with AChE is shown in the series of reactions in Figure A-III.

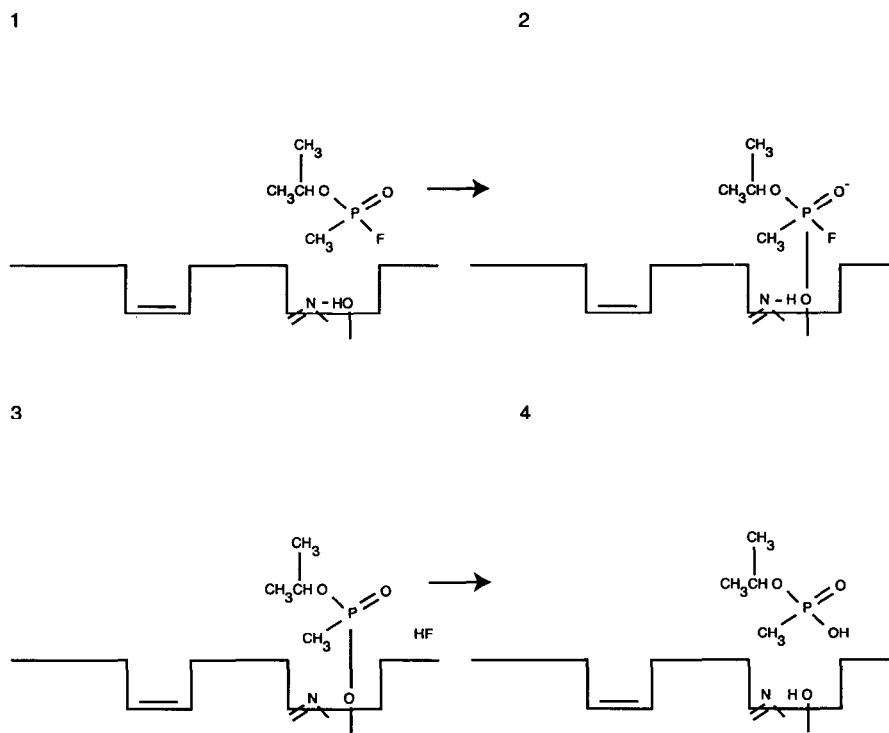


Figure A-III. GB and AChE Reactions

- f. Unlike the hydrolysis of acetylcholine, however, this series of reactions is slow as a result of the very slow, and rate limiting, final step (3-4) in Figure A-II. This stage takes place so slowly that in practical terms no regeneration of enzyme takes place and if the dose of organophosphate is sufficiently large the patient dies.
- g. Another reaction may be added to the above series: the reaction describing the process of AGING 11:



- h. This loss of an alkyl group produces a very stable agent-enzyme complex which is then resistant to spontaneous hydrolysis and reactivation by oximes. The rate of aging is dependent on the nature of the alkyl group and is fairly slow (hours) in the case of GB or VX but is very rapid (minutes) in the case of GD.
- i. Aging is the main cause of failure of compounds designed to speed reactivation of the enzyme to be of as much value in GD poisoning as they are in the treatment of GB or VX poisoning.



**NATO HANDBOOK ON THE MEDICAL ASPECTS  
OF NBC DEFENSIVE OPERATIONS  
AMedP-6(B)**

**PART III - CHEMICAL**

**ANNEX B**

**PHARMACOLOGY OF OXIMES**

**1 FEBRUARY 1996**

**TABLE OF CONTENTS**

	Page
Paragraph B.01. Composition of Oximes	B-3
Figure B-I. Formula of Pralidoxime	B-3
B-II. Formula of Obidoxime	B-3
B-III. Formula of Hagedorn Oximes	B-4
B-IV. Reactivation of GB Inhibited Enzyme by Pralidoximes	B-4

## ANNEX B

## PHARMACOLOGY OF OXIMES

## B.01. Composition of Oximes.

- a. The oximes comprise a group of compounds possessing one or more pyridinium rings and bearing one or more aldoxime groups. A large number of such compounds has been synthesised and are divided into:
- (1) Mono pyridinium oximes such as pralidoxime (pyridine-2-aldoxime methyl chloride, PAM Cl, pralidoxime methylsulphonate) (Figure B-I).

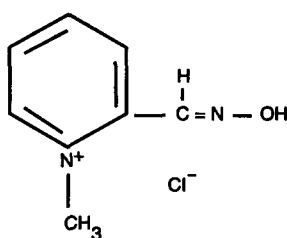


Figure B-I. Formula of Pralidoxime

- (2) Bispyridinium oxides including obidoxime (Toxogonin®) with the formula as shown in Figure B-II.

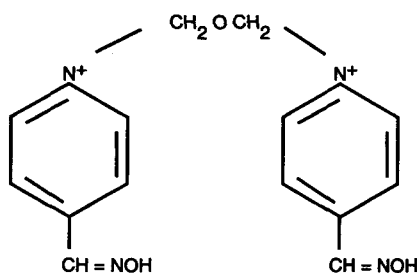


Figure B-II. Formula of Obidoxime

- b. Recently the new Hagedorn (H) oximes have been synthesised and these include the compounds H16 and HS6 as shown in Figure B-III.

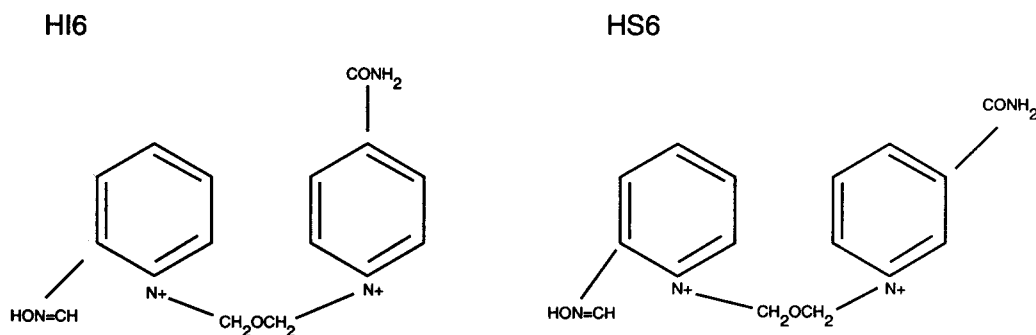


Figure B-III. Formula of Hagedorn Oximes

- c. The oximes are thought to act by combining with the modified nerve agent molecule and removing it from the acetylcholinesterase enzyme. They also have other pharmacological effects which may contribute to their efficacy.
- d. The sequence of reactions shown in Figure B-IV represents the reactivation of GB inhibited enzyme by pralidoxime.

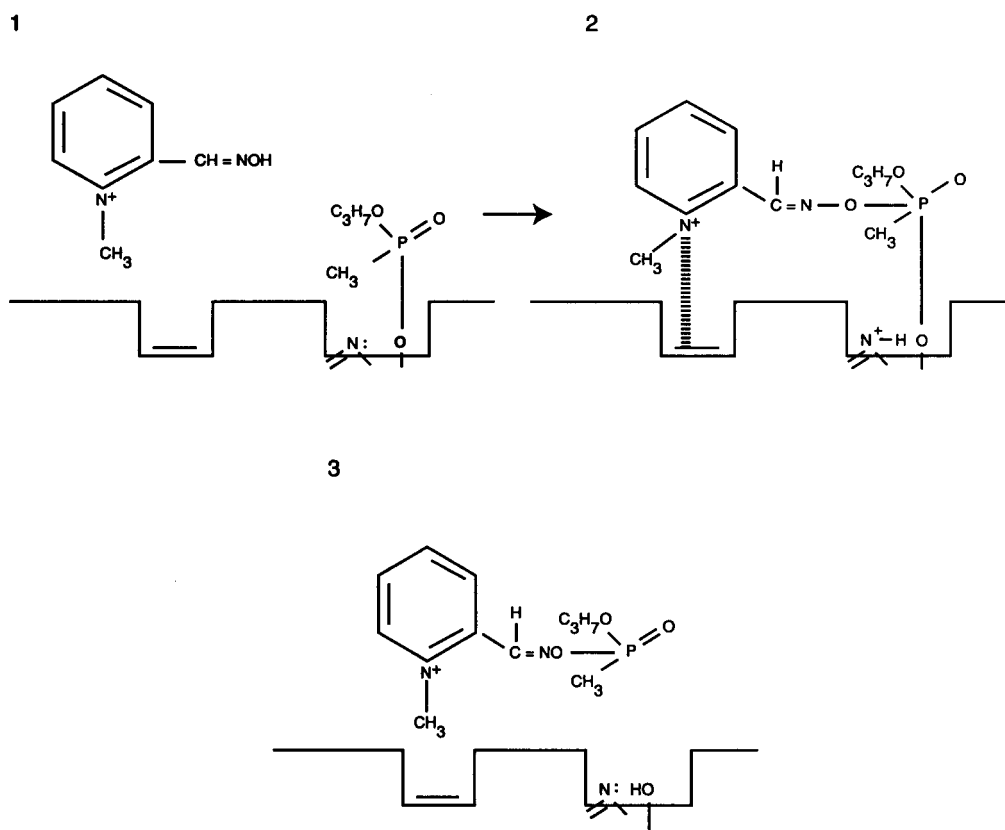


Figure B-IV. Reactivation of GB Inhibited Enzyme by Pralidoxime

**NATO HANDBOOK ON THE MEDICAL ASPECTS  
OF NBC DEFENSIVE OPERATIONS  
AMedP-6(B)**

**PART III - CHEMICAL**

**ANNEX C**

**SUMMARY OF THE EFFECTS OF CHEMICAL AGENTS**

**1 FEBRUARY 1996**

**TABLE OF CONTENTS**

	Page
Table C-I. Effects of Chemical Agents	C-3

ANNEX C  
SUMMARY OF THE EFFECTS OF CHEMICAL AGENTS

Table C-1. Effects of Chemical Agents

Agent	Symbol	Odour	Mechanism of action	Eyes (pupils)	Eyes (conjunctivae)	Rest of eye
Tabun; Sarin; Soman; GF.	GA GB GD GF	None or faint sweetishness, fruity or paint-like.	Anticholinesterase agents.	Miosis.	Redness.	Pain, especially on focusing, dimness of vision, headache, lachrymation.
VX	VX	None.				
Mustard and nitrogen mustard.	H HD HN	Garlic or horseradish, irritating. None or fishy, irritating.	Vesicants. Bone marrow depressant. Alkylating agents, damages DNA.	Mydriasis.	Redness, oedema, irritation, gritty pain.	Oedema of lids, pain, blepharospasm, photophobia, lachrymation, corneal ulceration and possibly scarring.
Lewisite and other arsenical vesicants.	L	Fruity to geranium- like. Irritating.	Vesicants. Arsenical poisons.		Prompt redness, oedema, irritation.	Immediate burning sensation, iritis, corneal injury.
Mustard/Lewisite mixture.	HL	Garlic-like.	Like lewisite and mustard.	Like HD, HN and L	Like HD, HN and L.	Like HD, HN and L.
Phosgene oxime.	CX	Unpleasant and irritating.	Powerful vesicant.		Violently irritating, redness, oedema.	Corneal injury with blindness, lachrymation.
Phosgene.	CG	Green corn, grass or new-mown hay.	Lung damaging agent.		Irritation.	Lachrymation (after respiratory symptoms).
Hydrogen cyanide.	AC	Faint bitter almonds.	Interferes with oxygen utilisation at cellular level.			
Cyanogen chloride.	CK	Very irritating.	Like hydrogen cyanide, lung irritant.		Irritation.	Lachrymation.
Vomiting agents.	DM DA DC	Burning fireworks, very irritating.	Local irritant, induces vomiting.		Irritation.	Lachrymation.
Irritant agents.	CN CA	Irritating.	Local irritant.		Redness, irritation.	Pain, blepharospasm, profuse lachrymation, photophobia.
	CS CR	Very irritating, pungent, pepper- like.	Local irritant.		Intense irritation.	Pain, blepharospasm, lachrymation, photophobia.
Incapacitating agents.	BZ	None.	Anticholinergic.	Mydriasis.		Blurred vision.
	LSD	None.	Psychomimetic.	Mydriasis.		

Table C-I. Effects of Chemical Agents (continued)

Symbol	Nose and throat	Respiratory tract	Skin	GI tract	Cardiovascular system
GA GB GD GF VX	Increased salivation. Rhinorrhoea.	Tightness in the chest, bronchoconstriction, occasional wheezing, increased bronchial secretion, cough, dyspnoea, substernal tightness.	Sweating, pallor then cyanosis.	Salivation, anorexia, nausea, vomiting, abdominal cramps, epigastric tightness, heartburn, eructation, diarrhoea, tenesmus, involuntary defecation.	Occasional early transient tachycardia and/or hypotension followed by bradycardia and hypotension.
H HD HN	Swelling, irritation, ulceration, discharge, occasional oedema of larynx.	Slowly developing irritation, hoarseness, aphonia, cough, tightness, dyspnoea, rales. Pneumonia, fever, pulmonary oedema, in severe cases. Risk of secondary infection.	No immediate signs. After minutes to hours, redness and burning. Several hours later blisters surrounded by redness and itching. Several days later necrosis, generally limited to epidermis. Delayed hyper- and hypo-pigmentation. Moist areas affected most. Risk of secondary infection.	Pain, nausea, vomiting, diarrhoea.	Shock after severe exposure.
L HL	Prompt irritation.	Rapid irritation, hoarseness, aphonia, cough, pneumonia, fever, pulmonary oedema, pleural effusion in severe cases.	Prompt burning. Red within 30 minutes. Blisters on 1st or 2nd day. Pain worse and necrosis deeper than H.	Diarrhoea, nausea, vomiting, hepatic failure.	Shock after severe exposure. Haemolytic anaemia, haemo-concentration.
CX	Very irritating to mucous membranes.	Rapid irritation and coughing. Later pulmonary oedema.	Immediate severe irritation and intense pain. Within 1 minute the affected area turns white, surrounded by erythema. Swollen within 1 hour; blistered after 24 hours. Necrosis may occur. Long recovery (1-3 months).		
CG	Irritation.	Coughing, choking, chest tightness on exposure. Latent period, then pulmonary oedema, dyspnoea, frothy sputum, rales, pneumonia and fever.	Possible cyanosis following pulmonary oedema.	Nausea, occasional vomiting after respiratory symptoms.	Shock after severe exposure, hypotension and tachycardia.
AC		Deep respiration followed rapidly by dyspnoea, gasping then cessation of respiration.	Initially pinker than usual; may change to cyanosis.	Nausea.	Profound hypotension.
CK	Irritation.	Irritation, cough, choking, dyspnoea; pulmonary oedema can be rapid.		Like hydrogen cyanide.	
DM DA DC	Pain, rhinorrhoea, tightness, sneezing.	Tightness and pain, uncontrollable coughing.	Stinging, (especially of face), occasional dermatitis.	Salivation, nausea vomiting.	
CN CA	Irritation, burning.	Tightness and irritation if concentration is high.	Stinging, (especially of face) occasional dermatitis, may blister.	Occasional vomiting.	
CS CR	Irritation, burning, tightness.	Tightness in chest and difficulty breathing.	Stinging, occasional dermatitis, may blister.	Nausea and vomiting.	
BZ	Extreme dryness.		Dry, flushed.	Constipation.	Tachycardia, elevated blood pressure.
LSD			Sweaty palms, cold extremities.		Tachycardia.



Table C-I. Effects of Chemical Agents (continued)

Symbol	Genito-urinary system	Central nervous system	Other	Treatment
GA GB GD GF VX	Frequent micturition, urinary incontinence.	Apprehension, giddiness, insomnia, headache, drowsiness, difficulty concentrating, poor memory, confusion, slurred speech, ataxia, weakness, coma with areflexia, Cheyne-Stokes respiration, convulsions.	Fasciculations, easy fatigue, cramps, weakness (including respiratory muscles), paralysis.	Pre-treatment with pyridostigmine. Post-exposure therapy: a. Cholinergic blockage - atropine. b. Enzyme reactivation - oximes. c. Anticonvulsant - diazepam. d. Assisted ventilation. e. Suction for respiratory secretions.
H HD HN		Anxiety, depression.	Late depression of bone marrow, malaise and prostration.	Eyes: antibiotics, cyclopegics and systemic analgesia. Skin: local dressings and antibiotics for infection. Antibiotics for respiratory infection. IV fluids.
L	Renal failure.	Anxiety, depression.	Systemic arsenic poisoning.	Like sulphur and nitrogen, mustards. BAL in oil IM for systemic chelation. BAL ointment for eyes and skin.
HL		Anxiety, depression.		Like sulphur mustard, nitrogen mustard and lewisite.
CX		Anxiety, depression.		Apply dressings of sodium bicarbonate. Systemic analgesics. Treat as any other necrotic skin lesion.
CG		Anxiety, depression.		Corticosteroids IV and by inhalation promptly may be life-saving. Rest, oxygen, antibiotics.
AC		May have initial excitation; then depression, giddiness, headache, irrational behaviour, ataxia, convulsions or coma.		Drugs binding cyanide: a. Methaemoglobin formers; nitrites or DMAP. b. Scavengers; dicobalt edetate and hydroxocobalamin. Provision of S-groups; thiosulphate. Assisted ventilation. Oxygen.
CK				Like hydrogen cyanide and phosgene.
DM DA DC		Severe headache, mental depression.	May cause desire to remove respirator.	Wear mask in spite of symptoms. Spontaneous improvement.
CN CA		Headache.		Spontaneous improvement. Analgesic eye and nose drops if necessary.
CS CR		Headache.		Symptoms disappear rapidly in fresh air.
BZ	Urgency, urinary retention.	Headache, giddiness, drowsiness, disorientation, hallucinations and occasional maniacal behavior. Ataxia and/or lack of coordination.		Restraint, cool environment. Physostigmine. Treatment may be required over several days.
LSD		Mental excitation, poor concentration, tremor indecisiveness, inability to act in a sustained or purposeful manner. Hallucinations.	Pyrexia.	Reassurance, restraint, prompt evacuation, diazepam.

## REFERENCES

*General*

Beswick, F.W., Maynard, R. "Poisoning in Conflict," in *Oxford Textbook of Medicine*, Eds. Wetherall, D. L., Ledingham, J.G.G., and Warren, D.A. Pub. Oxford University Press.

*Medical Manual of Defence Against Chemical Agents (JSP 312)*. Publisher: Her Majesty's Stationery Office, 1987.

*Nerve Agents*

Gall, D. "The Use of Therapeutic Mixtures in the Treatment of Cholinesterase Inhibition." *Fundamental and Applied Toxicology*, 1:214-216, 1981.

Grob, D., Harvey, J.C. "Effects in Man of the Anticholinesterase Compound Sarin." Dept. of Medicine, Johns Hopkins University, Baltimore, MD, Vol 37, 1958.

Grob, D. "The Manifestations and Treatment of Poisoning Due to Nerve Gas and Other Organic Phosphate Anticholinesterase Compounds." *Arch Int. Med.*, Vol 98, 1956.

Grob, D., Johns, R.I. "Use of Oximes in the Treatment of Intoxication by Anticholinesterase Compounds in Normal Subjects." *The American Journal of Medicine*, Vol XXIV, 4:497-518.

Hayes, W.J. "Organic Phosphorus Pesticides." *Pesticide Studies in Man*. Williams and Wilkins, Baltimore, 1982.

Martin, L.J., Doebler, J.A. et al. "Protective Effect of Diazepam Pre-treatment on Soman Induced Brain Lesion Formation." *Brain Research*, 325:287-289, 1985.

McCloud, C.G., Singer, A.W., Barrington, D.G. "Acute Neuropathy in Soman Poisoned Rats." *Neurotoxicology*, 5(2):53-58, 1984.

McDonagh, J. H., Jaax, N.K. et al. "Atropine and/or Diazepam Therapy Protects Against Soman Induced Neural and Cardiac Pathology." *Fundamental and Applied Toxicology*, 13:256-276, 1989.

Nambe, T., Nolte, C.T. et al. "Poisoning Due to Organophosphate Insecticides; Acute and Chronic Manifestations." *American Journal of Medicine*, Vol 50, Apr 1971.

Rickett, D. L., Glenn, J. F., Beers, E.T. "Central Respiratory Effects Versus Neuromuscular Actions of Nerve Agents." *Neurotoxicology*, 7(1):225-236, 1986.

Sidell, F. R., Groff, W.A. "The Reactivatability of Cholinesterase Inhibited by VX and Sarin in Man." *Toxicology and Applied Pharmacology*, 27:241-252, 1974.

### ***Vesicants***

Augerson, W. S., Sivak, A., Madey, W.S. *Chemical Casualty Treatment Protocol Development - Treatment Approaches*. Cambridge, Mass, Arthur D Little, Inc. Vol II-IV, 1986.

Buscher, H. *Green and Yellow Cross*, Trans. Conway, N. (1944). Cincinnati, Kettering Laboratory of Applied Physiology, University of Cincinnati, 1931.

Cullumbine, H. *Mustard Gas: Its Mode of Action and the Treatment of its Local and General Effects*. Porton Down, United Kingdom, Chemical Defence Establishment.

Gross, C. L., Meier, H.L. et al. "Sulphur Mustard Lowers NAD Concentrations in Human Skin Grafted to Athymic Nude Mice." *Toxicol Appl Pharmacol*, 81:85-90, 1985.

Norman, J. E., Jr. "Lung Cancer Mortality in World War One Veterans with Mustard Gas Injury: 1919- 1965." *J Natl Cancer Inst.*, 54:311-317, 1975.

Papirmeister, B., Gross, C.L. et al. "Molecular Basis for Mustard-Induced Vesication." *Fund Appl Toxicol*, 5:S134-S149, 1985.

Papirmeister, B., Gross, C.L. et al. "Pathology Produced by Sulphur Mustard in Human Skin Grafts on Athymic Nude Mice: I. Gross and Light Microscopic Changes." *J Toxicol-Cut and Ocular Toxicology*, 3:371-391, 1984.

Papirmeister, B., Gross, C.L. et al. "Pathology Produced by Sulphur Mustard in Human Skin Grafts on Athymic Nude Mice: II. Ultrastructural Changes." *J Toxicol-Cut and Ocular Toxicology*, 3:393-408, 1984.

*Potential Military Chemical/Biological Agents and Compounds*. FM 3-9, Washington, DC, HQ, Dept of the Army, 1990.

Renshaw, B. "Mechanisms in Production of Cutaneous Injuries by Sulphur and Nitrogen Mustards," in Bush, V.(ed): *Chemical Warfare Agents and Related Chemical Problems*. Washington, DC, Office of Scientific Research and Development, Part 3, Ch 23, 1946, pp 479-518.

*Treatment of Chemical Agent Casualties and Conventional Military Chemical Injuries*. FM 8-285, Washington, DC. HQ, Dept of the Army, Feb. 1990.

Vedder, E.B. *The Vesicants, The Medical Aspects of Chemical Warfare*. Baltimore, Williams and Wilkins Co., Ch 8, 1925, pp 125-166.

*Vesicant Injury to the Eye, Part II, Laboratory Studies.* Bulletin, Johns Hopkins Hosp., 948;82:81-352.

Wada, S., Miyanishi, M. et al. "Mustard Gas as a Cause of Respiratory Neoplasia in Man." *Lancet*, 1968;1:1161-1163.

Warthin, A. S., Well, C.V. *The Medical Aspects of Mustard Gas Poisoning.* St. Louis. CV Mosby Co., 1919.

Willems, J.L. "Clinical Management of Mustard Gas Casualties." *Annales Medicinæ Militaris Belgicae*, 1989, Vol 3 supp. Heymans Institute of Pharmacology, University of Ghent Medical School and Royal School of the Medical Services, Leopoldskazerne, B-900 Ghent, Belgium.

Yamada, A. "On the Late Injuries Following Occupational Inhalation of Mustard Gas, with Special Reference to Carcinoma of the Respiratory Tract." *Acta Pathologic Jpn*, 13:131-155, 1963.

### ***Cyanide***

Ballantine, B. *Clinical and Experimental Toxicology of Cyanides.* Wright, 1987.

Brewer, T.G. *Therapy for Cyanide Poisoning.* Pharmacology Division of USAMRICD/Experimental Therapeutics Division WRAXR.

Chen, K.K. "Amyl Nitrite and Cyanide Poisoning." *JAMA*, 17 June 1993.

*Cyanide Antidote Package.* Eli Lilly and Company, PA 0705 AMP.

Evans, C.L. "Cobalt Compounds as Antidotes for Hydrocyanic Acid." *British Journal of Pharmacology*, Feb 1964.

Graham, D.L. "Acute Cyanide Poisoning Complicated by Lactic Acidosis and Pulmonary Oedema." *Archives of Internal Medicine*, Vol 137, Aug 1977.

Marrs, T.C. "Antidotal Treatment of Acute Cyanide Poisoning." *Adverse Drug Reactions Acute Poisoning Revue.* 1988; 4:179-206.

*Treatment of Chemical Agent Casualties and Conventional Military Chemical Injuries.* FM 8-285, Washington, DC, HQ, Dept of the Army, Feb. 1990.

### ***Phosgene***

Diner, W.F. *Pathogenesis of Phosgene Poisoning.* Department of Occupational Health, Bayer AG, D-5090 Leverkusen, Federal Republic of Germany.

Diner, W.F., Zante, R. *A Literature Review: Therapy for Phosgene Poisoning*. Department of Occupational Health, Bayer AG, D-5090 Leverkusen and University of Dusseldorf, Federal Republic of Germany.

Diller, W.F. "Late Sequelae After Phosgene Poisoning: A Literature Review." *Toxicology and Industrial Health*, Vol 1, Mo 2, 1985.

Diner, W.F. "Early Diagnosis of Phosgene Overexposure." *Toxicology and Industrial Health*, Vol 1, Mo 2, 1985.

Diner, W.F. *Therapeutic Strategy in Phosgene Poisoning*. Department of Occupational Health, Bayer AG, D-5090 Leverkusen, Federal Republic of Germany.

Galdston, M. Hopson, et al. *A Study of the Residual Effects of Phosgene Poisoning in Human Subjects: I. After Acute Exposure*. Clinical Research Section, Medical Division, Chemical Warfare Service, Edgewood Arsenal, MD, and the Department of Medicine, Johns Hopkins Hospital, Baltimore, MD, March 4, 1946.

Gilchrist, H.L. "The Residual Effects of Warfare Gases: The Use of Phosgene Gas, with Report of Cases." *The Medical Bulletin of the Veterans' Administration*, Vol 10, No 1, July 1933.

Polednak, A. P., Hollis, D.R. "Mortality and Causes of Death Among Workers Exposed to Phosgene in 1943 -1945." *Toxicology and Industrial Health*, Vol 1, No 2, 1985.

Regan, R.A. "Review of Clinical Experience in Handling Phosgene Exposure Cases." *Toxicology and Industrial Health*, Vol 1, No 2, 1985.

Seidelin, R. *The Inhalation of Phosgene in a Fire Extinguisher*. Royal Air Force Hospital, Nocton Hall, May 6, 1960.

Wells, B.A. "Phosgene: A Practitioner's Viewpoint." *Toxicology and Industrial Health*, Vol 1, No 2, 1985.

### ***Riot Control***

Ballantine, B. "Riot Control Agents." *Biochemical and Health Aspects of the Use of Chemicals in Civil Disturbances*. Special Article, pp 7-41.

Ballantine, B., Callaway, S. "The Toxicology and Pathology of Animals Exposed to O-Chlorobenzylidene Malononitrile (CS)." *Medicine, Science and Law*, Vol 12,34-65, 1962.

Cucinell, S. A., Swentzel, K.C. et al. "Biochemical Interactions and Chemical Fate of Riot Control Agents." *Fed. Proc.* Vol 30; 1:Jan-Feb 1971.

- Hellreich, A., Mershon, M.M. et al. "An Evaluation of the Skin Irritant Potential of CS Aerosols on Human Skin Under Tropical Climatic Conditions." *Edgewood Arsenal Technical Report, EATR 4252*.
- Punte, C.L., Owens, E.J., Gutentag, P.J. "Exposures to Orthochlorobenzylidene Malononitrile; Controlled Human Exposures." *Arch. of Environmental Health*, Vol 6;72-80, 1963.
- Shumes, E., Taylor, J.S. "Industrial Contact Dermatitis: Effects of the Riot Control Agent Orthochlorobenzylidene Malononitrile." *Arch Dermatol*. Vol 107, Feb 1973.
- Rengstorff, R.H. "Tear Gas and Riot Control Agents: A Review of Eye Effects." *The Optometric Weekly*, Sept 1969.
- Report of the Enquiry into the Medical and Toxicological Aspects of CS, Part II*. Her Majesty's Stationery Office, London, Sept 1971.
- Stein, A.A., Kirwan, W.E. "Chloracetophenone (Tear Gas) Poisoning: A Clinico-Pathologic Report." *Current Topics*, Vol 9;3:374-382.
- Weigand, D.A. "Cutaneous Reaction to the Riot Control Agent CS." *Military Medicine*, pp 437-440.

### ***Incapacitants***

- Dauderer, M. "Physostigmine Salicylate as an Antidote." *International Journal of Clinical Pharmacology, Therapy and Toxicology*, Vol 18;12:523-535, 1980.
- Duvoisin, R. C., Katz, R. "Reversal of Central Anticholinergic Syndrome in Man by Physostigmine." *JAMA* Vol 206;9:455-458, Nov 25, 1968.
- Granacher, R.P. "The Central Anticholinergic Syndrome: Management with Physostigmine." *The Journal of the Kentucky Medical Association*, pp 147-148, March, 1975.
- Lauwers, L. F., Daelemans, R. et al. "Scopolamine Intoxications." *Intensive Care Medicine* 9:283-285, 1983.
- Miller, J.J., Ferrer, G.R. "Atropine Coma: A Somatic Therapy in Psychiatry." *JAMA* Vol 206;9:455-457, Nov 25, 1968.
- Sidell, F.R. "Use of Physostigmine by the Intravenous, Intramuscular and Oral Routes in the Therapy of Anticholinergic Drug Intoxication." *Edgewood Arsenal Technical Report, EB-TR-76012*.
- Walker, W. E., Levy, R. C., Hanenson, LB. "Physostigmine - Its Use and Abuse." *JACEP* 5:436-439, June, 1976.

## GLOSSARY

2,4,5-T	2,4,5-trichlorophenoxyacetic acid
2,4,-D	2-4-dichlorophenoxyacetic acid
AC	hydrogen cyanide
ACh	acetylcholine
AChE	acetylcholinesterase
BA	bromoacetone
BAL	British anti lewisite
BZ	3-quinuclidinyl benzilate (an incapacitating agent)
C	celsius
CA	bromobenzyl cyanide (irritant agent)
CARM	chemical agent resistant material
CG	phosgene
CK	cyanogen chloride
cl	chlorine
cm	centimeter
CN	chloracetophenone (irritant agent)
CNS	central nervous system
Co-A	coenzyme-A
CR	dibenzoxazepine
CS	ortho-chlorobenzylidene malononitrile
CSA	chlorosulphonic acid
CSR	combat stress reaction
Ct	concentration time
CW	chemical warfare
CX	phosgene oxime
DA	diphenylchlorarsine
DC	diphenylcyanarsine
DM	diphenylaminearsine chloride (adamsite)
DMSA	meso-dimercaptosuccinic acid
DMAP	4-dimethylaminophenol-hydrochloride
DMPA	N-(2,3-dimercaptopropyl)-phthalamidic acid
DMPS	2,3-dimercapto-1-propanesulfonic acid
DNA	deoxyribonucleic acid
DP	diphosgene
ECG	electrocardiogram
F	Fahrenheit
FM	titanium tetrachloride
GA	tabun
G-agent	a non-persistent nerve agent
GB	sarin
GD	soman

H	sulphur mustard
Hb	hemoglobin
HC	zinc chloride smoke mixture
HCl	hydrochloric acid
HCN	hydrogen cyanide
HD	distilled sulphur mustard
HI6	type of oximide
HN	nitrogen mustard
HN1	N-ethyl-2,2' di(chloroethyl)amine (type of nitrogen mustard)
HN2	N methyl-2,2' di(chloroethyl)amine (type of nitrogen mustard)
HN3	2,2',2'' tri(chloroethyl)amine (type of nitrogen mustard)
ICt	incapacitating concentration time
ID	incapacitating dose
IPE	individual protective equipment
IPPB	intermittent positive pressure breathing
IPPV	intermittent positive pressure ventilation
kg	kilogram
kg <sup>-1</sup>	per kilogram
L	lewisite
LCt	lethal concentration time
LD	lethal dose
LSD	lysergic acid diethylamide
m <sup>3</sup>	cubic meter
metHb	methaemoglobin
ug	microgram
mg	milligram
Mg	magnesium
mm	millimeter
mmHg	millimeters of mercury
Na	sodium
NA	nerve agent
NATO	North Atlantic Treaty Organisation
NBC	nuclear, biological and chemical
OP	organophosphate
P <sub>2</sub> S	pralidoxime
PEEP	positive end-expiratory pressure
PFIB	perfluoroisobutylene
ppm	parts per million
PS	chloropicrin
RNA	ribonucleic acid
RP	red phosphorus
SH	(percentage) saturation of hemoglobin
STANAG	standardization agreement
TH	thermite



V-agent	a persistent nerve agent
VX	methylphosphonothioic acid
WBGT	wet bulb gradient temperature
WP	white phosphorus

INDEX

Paragraph

AC	501, Table C-I
acetylcholine	206, 207, 223, A.01
acetylcholinesterase	206, 219, 224, A.01, B.01
aerosols	106, 605, 721
agents	106, 224, 226, 605, 1118
airway obstruction	212, 216
alcohol	605, 703
amphetamines	603
anaemia	312, 314, 343, 605
analeptics	409
analgesics	317, 318, 1107, 1121, 1118, Table C-I
anoxia	214, 216
anticholinergics	222, 603, 604, 605
anticonvulsant	211, 221, Table C-I
antidote	344, 612, 1107, 1111
anxiety	214, 223, 329, 333, 349, 618, 605
arsenical vesicant	341, 346, 348
assisted ventilation	214, 216, 220, 221, 226, 830, Table C-I
ataxia	611, Table C-I
atelectasis	407
atropine	211, 216, 220-225, 345, 409, 610, 809, 816, 1005, 1118, Table C-I
BAL	344, 346, 349, 350, 1124, Table C-I
beclomethasone	409
benzalkonium	711
betamethasone	4-3
bleach	104, 306, 711, 1115, 1124
blepharospasm	309, 317, 340, 710, 718, Table C-I
blister agent	301, 324, 326, 327, 329-331, 348, 1210
bromobenzyl cyanide	720
bronchiolar epithelium	407
bronchitis	333, 409
bronchopneumonia	311, 804
buddy aid	217, 221, 1108, 1111
burns	308, 310, 318, 321-331, 341, 343, 347, 621, 718, 808-810, 812, 814, 815, 817-819, 826, 828, 830, 832
BZ	602, 609-612, 605, Table C-I
CA	720, 729, Table C-I
calamine lotion	318, 712
cannabinols	601, 604, 605
carbon monoxide	501, 510, 801,804, 813, 820, 822, 827, 1003
casualties	102-103, 209, 212, 214, 217, 226, 301, 309-310, 313,317-318, 321-330, 332, 342, 410, 604, 612, 713,727, 828, 830, 832, 1002-1003, 1005,1101-1118, 1123, 1124, 1127, 1126, 1206
central nervous system effects	211, 214
CG	401, 404, Table C-I
chloracetophenone	701, 715
chloropicrin	401, 407
chlorpromazine	619
choking agents	401-410,1002

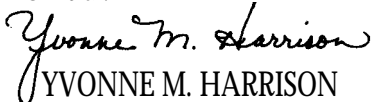
	Paragraph
cholinesterase enzymes	206-207
CN	502, 701, 703, 715-718, Table C-I
codeine	319, 409
conjunctivitis	309, 331, 340, 349, 710
contaminated clothing	815
convalescence	309, 1117
convulsions	214, 217, 221, 225-226, 207, 314, 507, 521, 617, 1002, Table C-I
cornea	309, 317, 329, 340, 345, 358, 707, 712, 718, 727, 808-810, Table C-I
cough	212, 217, 311, 319, 332, 348, 408-409, 521, 704, 721, 727-728, 804, 807-808, Table C-I
CS	102, 701-717, Table C-I
curare	1120
CX	352, Table C-I
cyanogen chloride	501, 515, 516, 519-521, Table C-I
cyanosis	212, 216, 408, 511, 521, 804, 806, Table C-I
death	212, 214, 216, 207, 333, 343, 407, 506, 511, 514, 521, 729, 801, 820, 823-824, 828, 832, 908
decontamination	104, 205, 221, 306, 308, 338, 341, 341, 356, 405, 505, 518, 606, 706, 711, 712, 1004, 1104, 1105, 1107, 1110, 1113, 1115, 1123, 1201, 1203, 1207, 1210-1211, 1213
depressant	Table C-I
depression	213-214, 216, 221, 223, 207, 314, 330, 333, 727, 905, 1004, 1120, 1122, 1118, Table C-I
dermatitis	323, 346, 712, 718, 808, Table C-I
dexamethasone	409
diarrhoea	210, 212, 219, 301, 313, 343, 710, 718, 727, 905, 910
diazepam	225, 619, Table C-I
dimercaprol	344-346, 349, 350, 1124
diphenylaminearsine chloride	721
diphenylchlorarsine	721
diphenylcyanarsine	721
disposition of casualties	604
dyspnoea	217, 311, 348, 408-409, 521, 704, 727, 804, 806, Table C-I
electrolyte	407
endotracheal	216, 221
erythema	209, 310, 316, 321-323, 325, 327-329, 341, 346, 358, 710, 712, 727, 914, Table C-I
evacuation	325, 327-328, 331, 409, 604, 712, 1107-1108, 1111-1114, 1121, 1123, Table C-I
eyes	204, 206, 209-210, 217, 207, 301, 306, 308-309, 317, 329, 340, 345, 356-358, 516, 519, 521, 706, 710-712, 718-719, 721, 726-728, 801, 807-808, 811-812, 814, 816, 909, 914-915, 1004, Table C-I
fibrosis	804
fire	401, 813, 826, 831-832
fluorescein	309, 317, 345, 809
food	106, 217, 306, 313, 615, 718, 727, 1201-1204, 1204, 1207-1211
fumes	401, 820, 822-823
genitalia	310, 318, 329, 331
gloves	204, 305, 327, 337, 355, 504, 608, 705, 1104
haemoconcentration	343, 406

	Paragraph
hands	309, 327-328, 331
headache	209, 214, 217, 219, 223-224, 314, 349, 408, 507, 710, 727-728, 824, 910, 1002, Table C-I
hydrogen cyanide	501-502, 504, 509, 515, 518-519, 522-523, Table C-I
hydrogen sulphide	501
hypoxaemia	212, 409
incapacitating agent	604, 605, 1002, Table C-I
incendiary	813, 826
indole	604, 617, 619, Table C-I
insecticide	201, 224
intubation	221, 409, 830
irritant	103, 306, 352, 501, 515, 519, 521, 701-703, 705, 711, 714, 716, 720, 722, 804, 820, 909, Table C-I
lachrymators	707, 720
leukopenia	312
lewisite	210, 301, 306, 328, 334-337, 339, 344-346, 350-351, 1103, 1124, Table C-I
liquid arsenical	340, 341, 343, 348
liquid nerve agent	203, 210
LSD	601, 604, 605, 613-619, Table C-I
lung	106, 207, 209, 212, 301-302, 332-333, 401, 404, 407-409, 519-521, 712, 728, 805, 826, 1118, 1121, Table C-I
magnesium	813, 819
mass casualties	1105, 1114
meat	901, 1203, 1204, 1205, 1210
methaemoglobin	508, 510-511, 1122, Table C-I
miosis	209, 211, 217, 219, 221, 223, 207, 345, 1002, Table C-I
muscarinic effects	2-6-2-6, 2-13, 2-15
mustard	102, 301-317, 320, 321-324, 327, 331-333, 335, 338, 341-342, 346, 1103-1104, 1117, 1118, 1124, 1203, 1204, 1205-1206, 1211-1212, Table C-I
neostigmine	612
nerve agent	201-204, 206-212, 214-224, 226, 604, 711, 1002-1003, 1106, 1111, 1117, 1118, 1124, 1203, 1204, 1205, 1211-1212
nicotinic effects	213
nitrogen mustard	301-303, 307, 323, Table C-I
nitrous fumes	401, 820
oedema	207, 309-311, 317, 323-329, 340, 342-345, 348, 358-359, 401, 406-410, 520-521, 708, 718, 727, 804, 808, 820, 828, 830, 832, 1121, Table C-I
ophthalmic	345
organophosphate	219, 224
orthopnoea	409
oxygen	409, 501-502, 506, 511, 513, 805, 814, 825, 827, 830, 1120-1122, Table C-I
phosgene	401-402, 406-407, 409, 404, 522, 804-805, 813, 1103, 1117, Table C-I
phosgene oxime	306, 352-358, Table C-I
photophobia	317, 345, 710, 808, Table C-I
physostigmine	612, Table C-I
pralidoxime	224
protection	102, 104, 204, 219, 302, 305, 308, 321, 325, 327, 355, 404, 502, 504, 605, 608, 615, 705, 724, 727, 801, 803, 814, 822, 829, 1104, 1109, 1125, 1201, 1207-1208
pruritus	

	Paragraph
pulmonary oedema	311, 342-343, 348, 358-359, 401, 406-410, 521, 708, 718, 727, 804, 820, 1121, Table C-I
pyridostigmine	2-11-2-12, 6-6, 11-11, 13-6
rations	Table C-I
respiratory	106, 204, 206, 209, 211-217, 221, 223, 207, 301, 308-309, 311, 319, 329-332, 342, 357-358, 408-4 09, 506, 511, 519-521, 605, 708, 710, 712, 718, 721, 726, 801, 803, 808, 810, 828, 830, 832, 1002, 1004, 1113, 1120, 1122, Table C-I
resuscitation	221, 346, 508, 511, 1111, 1118, 1120, 1122
rhinorrhoea	207, 209, 219, 311, 349, 704, 710, Table C-I
riot control	101-102, 601, 701-702, 713, 715, 720
sarin (GB)	201, Table C-I
skin	106, 202, 204-206, 210, 213, 217, 221, 301-310, 314, 318, 321, 324-325, 329-333, 339, 341, 343, 346, 348-349, 356-359, 408, 606, 611-612, 707, 710-712, 714, 718, 727-728, 807-817, 828, 830, 832, 905, 909, 914, 1104, 1115, 1123, Table C-I
smoke	101, 401, 409, 605, 701, 703, 716, 720, 722, 727-728, 801-804, 811, 814, 827, 829, 1004, 1201 619
sodium amytal	619
sodium bicarbonate	306, 356, 711, 809, 816, 1210, Table C-I
sodium carbonate	102, 711
sodium nitrite	510-511
sodium thiosulphate	102, 320, 510-512
soman	201, 219, 225, Table C-I
steroid	317-318, 407, 712, 805, 1121, Table C-I
stimulants	601, 603, 615
synechia	340
tabun	201, Table C-I
tear agent	102
thermite	813, 817, 819
time course of effects of nerve agents	208, 211
time course of effects of blister agents	332
titanium tetrachloride	811
tracheitis	319, 331
tracheotomy	830
training agent	702, 715
tremor	214, 605, Table C-I
vapour effects	209, 207
vertigo	507
vesicant	301-303, 308, 327-328, 334-335, 339-343, 346, 348, 711, 1118, 1124, Table C-I
VX	201-202, 1104, Table C-I
water	104, 202-203, 209, 212, 217, 221, 303-306, 313, 335, 344, 350, 353, 356, 402, 502-503, 511, 516, 517, 718-719, 720, 722, 727-728, 804, 807, 809, 814-818, 901, 915, 1100, 1126, 1201-1203, 1209-1213
weather	103, 223
white phosphorus	813-814, 1204
zinc chloride	401, 409, 801-804

By Order of the Secretaries of the Army, the Navy, and the Air Force:

Official:

  
YVONNE M. HARRISON  
*Administrative Assistant to the  
Secretary of the Army*

DENNIS J. REIMER  
*General, United States Army  
Chief of Staff*

HAROLD M. KOENIG  
Vice Admiral, Medical Corps  
United States Navy  
Surgeon General of the Navy

EDGAR R. ANDERSON  
Lieutenant General, USAF, MC  
Surgeon General

Distribution:

Active Army, Army National Guard, U.S. Army Reserve: To be distributed in accordance with the initial distribution number (IDN) 110809, requirements for FM 8-9.

Air Force: F